

Screening for Environmental Hazards at Sites with Contaminated Soil and Groundwater

Volume 2: Background Documentation for the Development of Tier 1 Environmental Action Levels

Appendices 2-5, 7-9 (Appendices 1 & 6 in separate pdf files)

Prepared by:

**Hawai'i Department of Health
Environmental Management Division
2385 Waimano Home Road
Pearl City, Hawai'i 96782**

Draft Spring 2024

Contacts:

Roger Brewer
Hawai'i Department of Health
Environmental Management Division
Hazard Evaluation and Emergency Response
Telephone: 1-808-586-4249
E-mail: roger.brewer@doh.hawaii.gov
<http://hawaii.gov/health/environmental/hazard/index.html>

OR

Roxanne Kwan
Hawai'i Department of Health
Environmental Management Division
Solid and Hazard Waste Branch
Telephone: 1-808-586-4226
E-mail: roxanne.kwan@doh.hawaii.gov

DISCLAIMER

This document, *Evaluation of Environmental Hazards at Sites with Contaminated Soil and Groundwater* (Spring 2024), is a technical report prepared by staff of the Hawai'i Department of Health (HDOH), Environmental Management Division. The document updates and replaces the Summer 2017 edition of the same document. A summary of the Spring 2024 updates is provided in Appendix 9.

The document provides guidance for identification and evaluation of environmental hazards associated with contaminated soil and groundwater. The Environmental Action Levels (EALs) presented in this document and the accompanying text are specifically *not* intended to serve as: 1) a stand-alone decision making tool, 2) guidance for the preparation of baseline environmental risk assessments, 3) a rule to determine if a waste is hazardous under the state or federal regulations, or 4) a rule to determine when the release of hazardous substances must be reported to the HDOH.

The information presented in this document is not final action. HDOH reserves the right to change this information at any time without public notice. This document is not intended, nor can it be relied upon, to create any rights enforceable by any party in litigation in areas associated with HDOH. HDOH may elect to follow the information provided herein or act at a variance with the information, based on an analysis of site-specific circumstances.

This document will be periodically updated. Please send comments, edits, etc. in writing to the above contact. This document is not copyrighted. Copies may be freely made and distributed. It is cautioned, however, that reference to the action levels presented in this document without adequate review of the accompanying narrative could result in misinterpretation and misuse of the information. Comments and suggestions for updates are welcome at any time.

VOLUME 2: BACKGROUND DOCUMENTATION FOR THE DEVELOPMENT OF TIER 1 SOIL AND GROUNDWATER ACTION LEVELS

APPENDICES

- 1 DEVELOPMENT OF TIER 1 LOOKUP TABLES
- 2 SUMMARY OF HUMAN HEALTH RISK-BASED EQUATIONS AND DEFAULT INPUT PARAMETER VALUES; USEPA REGIONAL SCREENING LEVELS USER'S GUIDE (MAY 2016)
- 3 RELEVANT PORTIONS OF *USER'S GUIDE FOR THE JOHNSON AND ETTINGER (1991) MODEL FOR SUBSURFACE VAPOR INTRUSION INTO BUILDINGS*; SENSITIVITY ANALYSIS OF *JOHNSON AND ETTINGER (1991) MODEL*
- 4 EXAMPLE PRINTOUTS OF VAPOR INTRUSION MODELS
- 5 DEVELOPMENT OF SOIL LEACHING SCREENING LEVELS
- 6 DEVELOPMENT OF CARBON RANGE AND TOTAL PETROLEUM HYDROCARBON RISK-BASED ACTION LEVELS
- 7 DETERMINATION OF GROUNDWATER UTILITY (HDOH 1995)
- 8 SUPPLEMENTAL HDOH TECHNICAL GUIDANCE DOCUMENTS
- 9 UPDATES TO 2011 EHE GUIDANCE DOCUMENT

GLOSSARY OF TERMS

AWQC: Aquatic Water Quality Criteria
CCC: Criterion for Continuous Concentration
CCM: Criterion for Maximum Concentration
EPA: Environmental Protection Agency
ESL: Environmental Screening Level
FVC: Final Chronic Value
HDOH: Hawai'i Department of Health
HH: Human Health-consumption of aquatic organisms
LOEL: Lowest-Observed-Effects Level
MADEP: Massachusetts Department of Environmental Protection
MCL: Maximum Concentration Level
MOEE: Ontario Ministry of Environment and Energy
MTBE: Methyl tert-Butyl Ethylene
PCE: Tetrachloroethylene
PRG: Preliminary Remediation Goals
RBSL: Risk-Based Screening Level
RSL: Regional Screening Level
RWQCB: Regional Water Quality Control Board
TPH: Total Petroleum Hydrocarbons
USEPA: U.S. Environmental Protection Agency
USDOE: U.S. Department of Energy

APPENDIX 2

SUMMARY OF HUMAN HEALTH DIRECT
EXPOSURE MODELS AND DEFAULT INPUT
PARAMETER VALUES

USEPA REGIONAL SCREENING LEVELS USER'S
GUIDE (NOVEMBER 2023)

EQUATIONS FOR DERIVATION OF RISK-BASED SCREENING LEVELS FOR SOIL, INDOOR AIR AND DRINKING WATER

1.0 Introduction

This appendix summarizes models and exposure assumptions used to generate risk-based action levels for soil, tapwater and indoor air that are incorporated into the HDOH Tier 1 Environmental Action Levels presented in Appendix 1. Risk-based action levels for soil and tapwater follow models and assumptions used to develop the USEPA Regional Screening Levels (RSLs, USEPA 2023). The RSLs represent a consolidation of Preliminary Remedial Goals (PRGs) previously published by individual USEPA regions. Previous editions of the HDOH guidance in particular referenced PRGs developed and published by USEPA Region IX (USEPA 2004a).

A copy of the 2023 USEPA RSL User's Guide is attached. This document presents a detailed discussion of the equations and assumptions used to calculate the RSLs. Risk-based soil action levels were developed for the following exposure scenarios:

- Residential direct exposure;
- Commercial/Industrial;
- Construction/Trench Workers.

The USEPA soil RSLs take into account the following routes of exposure:

- Incidental ingestion;
- Inhalation of vapors or dust;
- Dermal absorption.

Soil exposure assumptions for the Outdoor (vs indoor) Worker RSLs were referred to for incorporation in the Appendix 1 lookup tables (refer to Table I-2 in Appendix 1). The primary difference is an assumed, conservative soil ingestion rate of 100 mg/day in the action level models for outdoor workers rather than the 50 mg/day for indoor workers.

The USEPA RSL guidance only presents risk-based soil action levels for residential and commercial/industrial land use scenarios. A third set of action levels is incorporated into the HDOH Tier 1 EALs for construction and trench workers. A summary of exposure assumptions for all scenarios is provided in Table 1. References for the development of this exposure scenario are discussed in more detail below and in Appendix 1. The soil action levels can be used in site-specific Environmental Hazard Evaluations to evaluate in contaminants in deep or otherwise isolated soils to help target remedial efforts.

Soil action levels for contaminants that pose noncancer health risks were calculated for a target hazard quotient of both 1.0, following the approach used by USEPA, as well as more conservative hazard quotient of 0.2. Soil action levels based on a hazard quotient of 0.2 are carried forward for inclusion in the Tier 1 EAL lookup tables (refer to table A, B and I series). This was done in order to take into account potential cumulative effects posed by the presence of multiple contaminants with similar health effects. In most instances, this results in HDOH soil action levels for noncancer concerns that are one-fifth of the USEPA RSLs. In cases where the USEPA RSL exceeds the theoretical soil saturation level for a given chemical (C_{sat}), however, the difference will be less. As discussed in Appendix 1, C_{sat} is used as the upper limit for direct exposure soil action levels. The USEPA RSL and adjusted DOH action level will be identical both if the RSL and the DOH action level exceed this value. HDOH action levels for some chemicals may also differ slightly from the original USEPA RSL due to rounding inconsistencies between input values in the respective HDOH and USEPA spreadsheets.

The USEPA RSLs for tapwater take into account a similar set of assumed exposure routes:

- Direct ingestion of water;

- Inhalation of vapors during showering or other activities.

Equations used to develop the RSLs and similarly used to develop action levels for this guidance are presented in the attached USEPA RSL User's Guide.

The soil leaching model used in the USEPA RSL guidance was not referred to for use in the Tier 1 EALs. An alternative model used to develop soil action levels for this potential environmental hazard is discussed in Appendix 1.

2.0 Construction/Trench Workers Exposure Scenario

Direct-exposure screening levels for deep soils are calculated based on a construction/trench worker exposure scenario. Exposure assumptions are summarized in Table 1. The assumed exposed skin area and soil ingestion rate are based on guidance presented in the Supplemental Guidance for Developing Soil Screening Levels for Superfund Sites (USEPA 2002). The inhalation rate, child body weight, averaging time and target hazard quotient are set equal to assumptions used in the USEPA RSLs (USEPA 2023) for consistency with screening levels for occupational exposure assumptions. The default, USEPA body weight for adults was increased from 70 kg to 80 kg in the 2016 RSLs. The original, default body weight of 70 kg was retained for use in the HDOH EALs, due to a lower, average body weight for women in Hawaii of 66 kg (City-Data.com 2017). This does not significantly affect the resulting action levels. The original. The soil adherence factor is based on the default value for construction workers presented in the same document.

The Massachusetts Department of Environmental Protection assumes exposure durations of three months for noncarcinogens (plus use of subchronic RfDs) and seven years for carcinogens (MADEP 1994). A seven year (versus three month) exposure duration for carcinogens is used in part because shorter exposure durations were considered to be beyond the limits of cancer risk models. For the purposes of this document, a one-time, three-month exposure duration to exposed soils at a site was considered to be inadequate. This may be particularly true for utility workers who re-visit a site numerous times over several years for routine maintenance of underground utilities. As noted in Table 1, a total exposure duration of seven years is assumed for both carcinogens and noncarcinogens. An exposure frequency of 20 days (4 weeks) per year for 7 years yields a total of 140 days total exposure. Construction workers may receive 140 days (roughly 6 months) of exposure in a single year and never visit the site again. Using chronic RfDs (generally less stringent than subchronic RfDs) and spreading the total exposure time over seven years is somewhat conservative but is consistent with the utility worker scenario. A target risk of $1E-06$ was used to calculate soil screening levels for carcinogens. A target hazard quotient of 0.2 was used to calculate soil screening levels for noncarcinogens. This is consistent with assumption used to develop screening levels for residential and industrial/commercial exposure scenarios.

The emission of vapors from contaminated soil is based on part on the calculation of a "Volatilization Factor" on a chemical-specific basis (USEPA 2016, see equation in attached RSL guidance manual). A key parameter in this calculation is the term "Q/C," defined as the inversion of the ratio of the mean concentration of a VOC in air to the volatilization flux at the center of site (see VF equation in attachment). A default value of 68.81 is assigned to Q/C for standard residential and commercial/industrial site scenarios. A default Q/C value of 14.31 is assigned for use in trench worker exposure models for calculation of soil action levels for VOCs in order to take into account the potential for poor air flow in trenches (see Table I-3 in Appendix 1).

"Particulate Emission Factors (PEFs)" are intended to relate the concentration of a chemical in soil to the concentration of the chemical in air-borne dust. The PEF used for residential and occupational exposure scenarios ($1.316E+09$ mg-kg/mg/m³) was taken directly from the USEPA Region IX RSL guidance document (USEPA 2023). The PEF reflects a concentration of air-borne particulate matter of approximately 0.76 ug/m³. This PEF and associated concentration of air-borne dust was not considered to

be adequately conservative of conditions that may occur at construction sites. A revised PEF for this exposure scenario was derived through use of a "Dust Emission Factor" for construction sites developed by the USEPA. The Dust Emission Factor of 1.2 tons of dust per month, per acre is based on USEPA field studies at apartment complex and commercial center developments in semi-arid areas (USEPA 1974, 1985). Derivation of the construction-site PEF is summarized in Table 4. The derived PEF (1.44E+06 mg-kg/mg/m3) corresponds to a concentration of air-born dust of approximately 700 ug/m3.

3.0 INDOOR AIR

Target levels for indoor air were calculated based on equations incorporated into vapor intrusion spreadsheets published by the USEPA (USEPA 2004b). Refer to Appendix 4 for a copy of this guidance and a more detailed discussion of the equations. The equations are reproduced below for reference.

Equation 1: Residential Exposures to Carcinogenic Contaminants in Indoor Air

$$C_{air}(ug / m^3) = \frac{TR \times AT_c}{EF_{res} \times ED_{res} \times URF}$$

Equation 2: Occupational Exposures to Carcinogenic Contaminants in Indoor Air

$$C_{air}(ug / m^3) = \frac{TR \times AT_c}{EF_{occ} \times ED_{occ} \times URF}$$

Equation 3: Residential Exposures to Noncarcinogenic Contaminants in Indoor Air

$$C_{air}(ug / m^3) = \frac{THQ \times AT_{nc} \times RfC}{EF_{res} \times ED_{res}}$$

Equation 4: Occupational Exposures to Noncarcinogenic Contaminants in Indoor Air

$$C_{air}(ug / m^3) = \frac{THQ \times AT_{nc} \times RfC}{EF_{occ} \times ED_{occ}}$$

where URF is the unit risk factor carcinogens (ug/m3)⁻¹ for and RfC carcinogens (ug/m3) is the reference concentration for noncarcinogens. A summary of URFs and RfCs for specific chemicals is provided in Table H and E-3 of Appendix 1.

REFERENCES

City-Data.com, 2017, Health of Residents of Honolulu County Based on CDC Behavioral Risk Factors Surveillance System Survey Questionnaires from 2003 to 2012: City-data.com, Advameg, Inc., accessed October 14, 2017.

MADEP, 1994, *Background Documentation for the Development of the MCP Numerical Standards*: Massachusetts Department of Environmental Protection, Bureau of Waste Site Cleanup and Office of Research and Standards, April 1994.

- USEPA, 1974, Development of Emission Factors for Fugitive Dust Sources: U.S. Environmental Protection Agency, Publication No. EPA-450/3-74-037, (prepared by Cowherd, C., Axetell, K., Guenther, C., and Jutze, G., Midwest Research Institute).
- USEPA, 1985, Compilation of Air Pollutant Emission Factors, Volume 1: Stationary Point and Area Sources: U.S. Environmental Protection Agency, Office of Air and Radiation, Publication No. AP-42, Fourth Edition, September 1985.
- USEPA, 2002, Supplemental Guidance for Developing Soil Screening Levels for Superfund Sites: U.S. Environmental Protection Agency, Solid Waste and Emergency Response, OSWER 9355.4-24, December 2002.
- USEPA, 2004a, Preliminary Remediation Goals: U.S. Environmental Protection Agency, Region IX, October 2002, www.epa.gov/region09/waste/sfund/prg/intro.htm.
- USEPA, 2004b, *User's Guide for the Johnson and Ettinger (1991) Model for Subsurface Vapor Intrusion Into Buildings*: U.S. Environmental Protection Agency, Office of Emergency and Remedial Response, www.epa.gov/oerrpage/superfundrisk/airmodel/.
- USEPA, 2011, *Exposure Factors Handbook*: U.S. Environmental Protection Agency, Office of Research and Development. September 2011, EPA/600/R-090/052F www.epa.gov
- USEPA, 2023, *Regional Screening Levels*: U.S. Environmental Protection Agency, November 2023, prepared by Oak Ridge National Laboratories. <https://www.epa.gov/risk/regional-screening-levels-rsls-generic-tables>

**TABLE 1. HUMAN EXPOSURE PARAMETER DEFINITIONS
AND DEFAULT VALUES**

Symbol	Definition (units)	Default	References (refer to USEPA 2002 for full references)
CSFo	Cancer slope factor oral (mg/kg-d) ⁻¹	--	Chemical specific - Appendix 1, Table H
CSFi	Cancer slope factor inhaled (mg/kg-d) ⁻¹	--	Chemical specific - Appendix 1, Table H
RfDo	Reference dose oral (mg/kg-d)	--	Chemical specific - Appendix 1, Table H
RfDi	Reference dose inhaled (mg/kg-d)	--	Chemical specific - Appendix 1, Table H
TRr/o	Target cancer risk - residential, occupational/ industrial exposure scenario	10 ⁻⁶	USEPA 2023. See Appendix 1 Table I series and text for exceptions
*TRctw	Target cancer risk - construction/trench worker exposure scenario	10 ⁻⁵	HIDOH (see Appendix 1)
THQ	Target hazard quotient	0.2	HDOH (see Appendix 1 Table I series and text for exceptions)
BWa	Body weight, adult (kg)	70	CDC 2012
BWc	Body weight, child (kg)	15	USEPA 2023
ATc	Average time – carcinogens (days)	25,550	USEPA 2023
ATn	Average time – noncarcinogens (days)	ED*365	USEPA 2023
SAar	Exposed surface area, adult res. (cm ² /day)	6,032	USEPA 2023
SAaw	Exposed surface area, adult occ. (cm ² /day)	2,373	USEPA 2023
SAc	Exposed surface area, child (cm ² /day)	3,527	USEPA 2023
*SAac/tw	Exposed surface area, construction/trench worker (cm ² /day)	5,800	USEPA 2011b
AFar	Adherence factor, adult res. (mg/cm ²)	0.07	USEPA 2023
AFaw	Adherence factor, occupational (mg/cm ²)	0.12	USEPA 2023
*AFctw	Adherence factor, construction/trench worker (mg/cm ²)	0.30	USEPA 2023
AFc	Adherence factor, child (mg/cm ²)	0.20	USEPA 2023
ABS	Skin absorption (unitless): chemical specific	--	USEPA 2023
IRAA	Inhalation rate – adult (m ³ /day)	20	USEPA 2023
IRAc	Inhalation rate – child (m ³ /day)	10	USEPA 2023
*IRActw	Inhalation rate – construction/trench worker (m ³ /day)	20	USEPA 2011b
IRWa	Drinking water ingestion – adult (L/day)	2	USEPA 2023
IRWc	Drinking water ingestion – child (L/day)	0.78	USEPA 2023
IRSa	Soil ingestion – adult (mg/day)	100	USEPA 2023
IRSc	Soil ingestion – child (mg/day)	200	USEPA 2023)
IRSo	Soil ingestion – occupational (mg/day)	50	USEPA 2023
*IRSctw	Soil ingestion – construction/trench worker (mg/day)	330	USEPA 2002
Efr	Exposure frequency – residential (d/y)	350	USEPA 2023
Efo	Exposure frequency – occupational (d/y)	250	USEPA 2023
*EFctw	Exposure frequency – construction/trench worker (d/y)	20	Massachusetts DEP (1994)
EDr	Exposure duration – residential (years)	26	USEPA 2023
EDc	Exposure duration – child (years)	6 ^a	USEPA 2023
EDo	Exposure duration – occupational (years)	25	USEPA 2023
*EDctw	Exposure duration – construction/trench worker (years)	7	modified from Massachusetts DEP (1994)
VFw	Volatilization factor for water (L/m ³)	0.5	USEPA 2023
PEFres/oc	Particulate emission factor (m ³ /kg) - residential/occupational exposure scenarios	1.32E+09	USEPA 2023
*PEFctw	Particulate emission factor (m ³ /kg) - construction/trench worker exposure scenarios	1.44E+06	Based on Construction Site Dust Emission Factors (USEPA 1974, 1985). See attached table.
VF _s	Volatilization factor for soil (m ³ /kg)	-	Chemical specific (USEPA 2002, 2023)
sat	Soil saturation concentration (mg/kg)	-	Chemical specific (USEPA 2002, 2023)

TABLE 2. VOLATILIZATION FACTOR PARAMETER DEFINITIONS AND DEFAULT VALUES

Parameter	Definition (units)	Default
VF_s	Volatilization factor M^3/kg	--
D_A	Apparent diffusivity (cm^2/s)	--
$Q/C_{default}$	Inverse of the mean conc. at the center of a 0.5-acre square source ($g/m^2\text{-s}$ per kg/m^3)	68.81 (USEPA 2023)
Q/C_{trench}	Inverse of the mean conc. at the center of a 0.5-acre square source ($g/m^2\text{-s}$ per kg/m^3)	14.31 (USEPA 2002)
T	Exposure interval (s)	9.5×10^8
ρ_b	Dry soil bulk density (g/cm^3)	1.5
θ_a	Air filled soil porosity (L_{air}/L_{soil})	0.28 or n-w
n	Total soil porosity (L_{pore}/L_{soil})	0.43 or $1 - (b/s)$
θ_w	Water-filled soil porosity (L_{water}/L_{soil})	0.15
ρ_s	Soil particle density (g/cm^3)	2.65
D_i	Diffusivity in air (cm^2/s)	Chemical-specific
H	Henry's Law constant ($atm\text{-}m^3/mol$)	Chemical-specific
H'	Dimensionless Henry's Law constant	Calculated from H by multiplying by 41 (USEPA 1991a)
D_w	Diffusivity in water (cm^2/s)	Chemical-specific
K_d	Soil-water partition coefficient (cm^3/g) = $K_{oc} \times f_{oc}$	Chemical-specific
K_{oc}	Soil organic carbon-water partition coefficient (cm^3/g)	Chemical-specific
f_{oc}	Fraction organic carbon in soil (g/g)	0.006 (0.6%)

TABLE 3. PARTICULATE EMISSION FACTOR PARAMETER DEFINITIONS AND DEFAULT VALUES - RESIDENTIAL/OCCUPATIONAL SCENARIOS

Parameter	Definition (units)	Default
*PEF	Particulate emission factor (m ³ /kg)	1.316 x 10 ⁹
Q/C	Inverse of the mean concentration at the center of a 0.5-acre-square source (g/m ² -s per kg/m ³)	90.80
V	Fraction of vegetative cover (unitless)	0.5
Um	Mean annual windspeed (m/s)	4.69
Ut	Equivalent threshold value of windspeed at 7 m (m/s) 11.32	11.32
F(x)	Function dependent on Um/Ut derived using Cowherd (1985) (unitless)	0.194

* Concentration dust in air (mg/m³) = 1/(PEF x (1 kg/1,000,000 mg)) = 0.0007 mg/m³

**TABLE 4. PARTICULATE EMISSION FACTOR FOR
CONSTRUCTION/TRENCH WORKER EXPOSURE SCENARIO**

Dust Generated (moderate to heavy construction) (M_{dust}):			
Dust Emission Factor (EF):	1.2 2400 1089	tons/mo-acre lbs/mo-acre kgs/mo-acre	USEPA 1974, 1985 conversion conversion
Volume Air Passing Over Site Per Month Per Acre (V_{air}):			
Length Perpendicular To Wind (L):	1 43560 4047 64	acre ft ² m ² m	Default EF area conversion conversion $L=Area^{0.5}$
Air Mixing Zone Height (MZ): Ave Wind Speed (V): Seconds per 30.4 Day Month (S): Volume Air (Volume-air):	2 4.69 2.63E+06 1.57E+09	m m/s sec/month m ³	model assumption USEPA 2004 (default PRG value) conversion $Volume-air=L \times MZ \times V \times S$
Average Concentration Dust in Air ($C_{dust-air}$):			
Concentration Dust ($C_{dust-air}$):	6.95E-07 0.695	kg/m ³ mg/m ³	$(C_{air} = M_{dust}/Volume-air)$ conversion
Particulate Emission Factor (PEF):			
Concentration soil in dust ($C_{dust-soil}$): PEF:	1,000,000 1.44E+06	mg/kg (mg/kg)/ (mg/m ³)	Model assumption - 100% (1000000 mg/kg) of dust is derived from on-site soil. $PEF=C_{dust-soil}/C_{dust-air}$

Attachment

USEPA Regional Screening Levels User's Guide (November 2023)

 An official website of the United States government



MENU

Risk Assessment

CONTACT US <<https://epa.gov/risk/forms/contact-us-about-risk-assessment>>

Regional Screening Levels (RSLs) - User's Guide

November 2023

To download the most recent Regional Screening Level tables, please go to the Generic Tables

<<https://epa.gov/risk/regional-screening-levels-rsls-generic-tables>> page.

For assistance/questions please use the Regional Screening Levels (RSLs) contact us <<https://epa.gov/risk/forms/contact-us-about-regional-screening-levels-rsls>> page.

Disclaimer

This user's guide recommends an approach based upon currently available information about risk assessment on CERCLA sites. This user's guide does not establish binding rules. Alternative approaches for risk assessment may be found to be more appropriate at specific sites, and not every situation is addressed by this guide (e.g., where site circumstances do not match the underlying assumptions, conditions, and models of the user's guide). Decisions to use alternative approaches and a description of any such approach should be documented.

Accordingly, when comments are received at individual CERCLA sites questioning the use of the approaches recommended in this user's guide, the comments should be considered, and an explanation provided for the selected approach.

Regional Screening Levels (RSLs)

- Home Page
<<https://epa.gov/risk/regional-screening-levels-rsls>>
- User's Guide
<<https://epa.gov/risk/regional-screening-levels-rsls-users-guide>>
- What's New
<<https://epa.gov/risk/regional-screening-levels-rsls-whats-new>>
- Frequent Questions
<<https://epa.gov/risk/regional-screening-levels-rsls-frequent-questions>>
- Equations
<<https://epa.gov/risk/regional-screening-levels-rsls-equations>>

It should also be noted that the screening levels (SLs) in these tables are based upon human health risk and do not address potential ecological risk. Some sites in sensitive ecological settings may also need to be evaluated for potential ecological risk. EPA's guidance "Ecological Risk Assessment Guidance for Superfund: Process for Designing and Conducting Ecological Risk Assessment" contains an eight step process for using benchmarks for ecological effects in the remedy selection process.

On this page:

1. Introduction

2. Understanding the RSL Website

2.1 General Considerations

2.2 Exposure Assumptions

2.3 Toxicity Values

2.4 Chemical-specific Parameters

2.5 Maximum Contaminant Levels (MCLs)

2.6 Understanding Risk Output on the RSL Website

3. Understanding Your Superfund Site

3.1 Developing a Conceptual Site Model

3.2 Background

3.3 Potential Problems

4. Land Use Descriptions, Equations and Technical Documentation

4.1 Resident

4.2 Composite Worker

4.3 Outdoor Worker

4.4 Indoor Worker

4.5 Construction Worker

4.6 Recreator

4.7 Ingestion of Fish

4.8 Soil to Groundwater

4.9 Supporting Equations and Parameter Discussion

5. Special Considerations

5.1 Cadmium

5.2 Lead

- RSL Calculator [☑](#)

<http://epa-prgs.ornl.gov/cgi-bin/chemicals/csl_search>

- Generic Tables

<<https://epa.gov/risk/regional-screening-levels-rsls-generic-tables>>

- Contact Us

<<https://epa.gov/risk/forms/contact-us-about-regional-screening-levels-rsls>>

- 5.3 Manganese
- 5.4 Vanadium Compounds
- 5.5 Uranium
- 5.6 Chromium (VI)
- 5.7 Aminodinitrotoluenes
- 5.8 PCBs and Aroclors
- 5.9 Xylenes
- 5.10 Arsenic
- 5.11 Total Petroleum Hydrocarbons (TPHs)
- 5.12 Soil Saturation Limit (C_{sat})
- 5.13 SL Theoretical Ceiling Limit
- 5.14 Target Risk
- 5.15 Screening Sites with Multiple Contaminants
- 5.16 Deriving Soil Gas SLs
- 5.17 Mutagens
- 5.18 Trichloroethylene (TCE)
- 5.19 Mercuric Chloride (and other Mercury salts)
- 5.20 Cyanide (CN⁻)
- 5.21 Thallic Oxide and Thallium Selenite
- 5.22 Polycyclic Aromatic Hydrocarbon
- 5.23 Refractory Ceramic Fibers (units in fibers)
- 5.24 Lanthanum Salts
- 5.25 MCLs for Trihalomethanes and Haloacetic Acids
- 5.26 Perchlorate
- 5.27 Styrene-acrylonitrile trimer (SAN Trimer)
- 5.28 *cis*- and *trans*-Chlordane Surrogate
- 6. Recommended Default Exposure Parameters**
- 7. References**

1. Introduction

The purpose of this website is to provide default screening tables and a calculator to assist Remedial Project Managers (RPMs), On Scene Coordinators (OSCs), risk assessors, and others involved in decision-making concerning CERCLA hazardous waste sites and to determine whether levels of contamination found at the site may warrant further investigation. Users within and outside the CERCLA program should use the tables or calculator results at their own discretion; they should take care to understand the assumptions incorporated in these results to apply the SLs appropriately.

The SLs presented in the Generic Tables are chemical-specific concentrations for individual contaminants in air, drinking water, and soil that, if exceeded, may warrant further investigation. The SLs generated from the calculator may be default or site-specific concentrations for individual chemicals in soil, air, water, sediment, and fish. Screening levels (SLs) identified on this website are likely to be used early in the process, at Remedial Investigation (RI) scoping and screening of chemicals. In addition, SLs may be initially identified early in the Remedial Investigation/ Feasibility Study (RI/FS) process (for example, at RI scoping) to select appropriate detection limits for RI sampling. It should be emphasized that SLs are not cleanup standards and should not be used as cleanup levels.

The term PRGs (Preliminary Remediation Goals) is used to describe a project team's early and evolving identification of possible remedial goals. PRGs developed in the FS will usually be based on site-specific risks and/or Applicable or Relevant and Appropriate Requirements (ARARs) and not on generic SLs.

2. Understanding the RSL Website

2.1 General Considerations

Risk-based SLs are derived from equations combining exposure assumptions with chemical-specific toxicity values.

2.2 Exposure Assumptions

Generic SLs are based on default exposure parameters and factors that represent Reasonable Maximum Exposure (RME) conditions for long-term/chronic exposures and are based on the methods outlined in EPA's Risk Assessment Guidance for Superfund, Part B Manual (1991) (PDF) <<https://semspub.epa.gov/src/document/hq/192>> (68 pp, 721 K) and Soil Screening Guidance documents (1996 (PDF) <<https://semspub.epa.gov/src/document/hq/211>> (89 pp, 863 K) and 2002 (PDF) <<https://semspub.epa.gov/src/document/hq/175878>> (187 pp, 2.2MB).

Site-specific information may warrant modifying the default parameters in the equations and calculating site-specific SLs, which may differ from the values in these tables. In completing such calculations, the user should answer some fundamental questions about the site. For example, information is needed on the contaminants detected at the site, the land use, impacted media and the likely pathways for human exposure.

Whether these generic SLs or site-specific screening levels are used, it is important to clearly demonstrate the equations and exposure parameters used in deriving SLs at a site. A discussion of the assumptions used in the SL calculations should be included in the documentation for a

CERCLA site.

2.3 Toxicity Values

In 2003, EPA's Superfund program revised its hierarchy of human health toxicity values, providing three tiers of toxicity values in a memo (PDF) <<https://semspub.epa.gov/src/document/hq/136>> (4 pp, 225 K). Three tier 3 sources were identified in that guidance, but it was acknowledged that additional tier 3 sources may exist. The 2003 guidance did not attempt to rank or put the identified tier 3 sources into a hierarchy of their own. However, when developing the screening tables and calculator presented on this website, EPA needed to establish a hierarchy among the tier 3 sources. The toxicity values used as “defaults” in these tables and calculator are consistent with the 2003 guidance. Chronic and subchronic toxicity values from the following sources, in the order in which they are presented below, are used as the defaults in these tables and calculator.

1. EPA's Integrated Risk Information System (IRIS <<https://epa.gov/iris>>).
2. The Provisional Peer Reviewed Toxicity Values (PPRTVs <<https://epa.gov/pprtv>>) derived by EPA's Superfund Health Risk Technical Support Center (STSC) for the EPA Superfund program. PPRTVs are archived (removed) when an IRIS profile is released, even if the IRIS profile indicates a toxicity value could not be derived. PPRTVs will retain subchronic values if IRIS releases a profile without subchronic values.
3. EPA's Office of Pesticide Programs (OPP) Human Health Benchmarks for Pesticides (HHBPs). In 2016 <<https://epa.gov/iris/developments-iris-program>> IRIS archived 51 <<https://epa.gov/iris/iris-pesticide-chemical-assessments-archived-july-2016>> chemical assessments for pesticides. For these 51 pesticides IRIS has instead recommended the use of the toxicity values presented in the HHBP table. These include RfDs (also referred to as chronic PADs) and OSFs (referred to as cancer quantification values). In 2016, OPP listed 363 pesticides in the HHBP table. Only the 51 archived by IRIS are used in the RSL calculations.
4. The Agency for Toxic Substances and Disease Registry (ATSDR [🔗](https://www.atsdr.cdc.gov/) <<https://www.atsdr.cdc.gov/>>) minimal risk levels (MRLs). An MRL [🔗](https://www.atsdr.cdc.gov/mrls/index.html) <<https://www.atsdr.cdc.gov/mrls/index.html>> is an estimate of the daily human exposure to a hazardous substance that is likely to be without appreciable risk of adverse non-cancer health effects over a specified duration of exposure. These substance specific estimates, which are intended to serve as screening levels, are used by ATSDR health assessors and other responders to identify contaminants and potential health effects that may be of concern at hazardous waste sites.
5. The EPA Office of Water <<https://epa.gov/aboutepa/about-office-water>> occasionally derives toxicity values presented in Health Advisories <<https://epa.gov/ground-water-and-drinking-water/drinking-water-health-advisories-pfoa-and-pfos>> or Human Health Toxicity Assessments <<https://epa.gov/chemical-research/human-health-toxicity-assessments-genx-chemicals>> for special case chemicals.

6. The California Environmental Protection Agency Office of Environmental Health Hazard Assessment (OEHHA [🔗](https://oehha.ca.gov/) <https://oehha.ca.gov/>) provides toxicity values for the State of California. The OEHHA Toxicity Criteria Database [🔗](https://oehha.ca.gov/chemicals) <https://oehha.ca.gov/chemicals> website should be monitored for any updates to the toxicity values.
7. EPA's HERA program has posted the final Office of Research and Development (ORD) Human Health Toxicity Values for Perfluoropropanoic Acid (PFPrA), Lithium bis[(trifluoromethyl)sulfonyl]azanide (HQ-115), and Trifluoro-N-(trifluoromethanesulfonyl)methanesulfonamide, 1,1,1- (TFSI) . These toxicity assessments provide actionable science to inform EPA decision contexts and were developed in response to a request for site-specific technical support. Please see U.S. EPA. ORD Human Health Toxicity Value for Perfluoropropanoic Acid and U.S. EPA. ORD Human Health Toxicity Value for Lithium bis [(trifluoromethyl)sulfonyl]azanide for more information.
8. The 11th Cycle of Groundwater Standards Proposals from the State of Wisconsin Department of Health Services [🔗](https://www.dhs.wisconsin.gov/publications/p02807.pdf) <https://www.dhs.wisconsin.gov/publications/p02807.pdf> includes recommended standards for 4 PFAS chemicals (Perfluoroundecanoic acid (PFUDA), Perfluorododecanoic acid (PFDoDA), Perfluorotetradecanoic acid (PFTetDA), and Perfluorooctadecanoic (PFODA)) as well as other chemicals. The EPA Office of Land and Emergency Management's (OLEM) Human Health Regional Risk Assessment Forum's (OHRRRAF) Toxicity Workgroup recommends using these values because toxicity values from the other sources do not exist. While the recommended state (Wisconsin) reference values were derived by a state whose toxicity values have not been used before, the state's toxicity information was determined by the OHRRRAF's Toxicity Workgroup to be based on similar methods and procedures as those used for other Tier 3 values.

9. In the Fall 2009, this new source of toxicity values used was added: screening toxicity values in an appendix to certain PPRTV assessments. While we have less confidence in a screening toxicity value than in a PPRTV, we put these ahead of HEAST toxicity values because these appendix screening toxicity values are more recent and use current EPA methodologies in the derivation, and because the PPRTV appendix screening toxicity values also receive external peer review. To alert users when these values are used, the key presents an "X" (for Appendix) rather than a "P" (for PPRTV). The following is taken from a PPRTV appendix and states the intended usage of appendix screening levels.

However, information is available for this chemical, which although insufficient to support derivation of a provisional toxicity value, under current guidelines, may be of limited use to risk assessors. In such cases, the Superfund Health Risk Technical Support Center summarizes available information in an appendix and develops a "screening value." Appendices receive the same level of internal and external scientific peer review as the PPRTV documents to ensure their appropriateness within the limitations detailed in the document. Users of screening toxicity values in an appendix to a PPRTV assessment should understand that there is considerably more uncertainty associated with the derivation of an appendix screening toxicity value than for a value presented in the body of the assessment. Questions or concerns about the appropriate use of screening values should be directed to the Superfund Health Risk Technical Support Center.

10. The EPA Superfund program's Health Effects Assessment Summary Table [↗](https://epa-heast.ornl.gov/) <https://epa-heast.ornl.gov/>. Values in HEAST are archived (removed) when an IRIS profile or a PPRTV paper is released, even if the PPRTV paper indicates a toxicity value could not be derived.

Users of these screening tables and calculator wishing to consider using other toxicity values, including toxicity values from additional sources, may find the discussions and seven preferences on selecting toxicity values in the attached Environmental Council of States paper useful for this purpose (ECOS website [↗](https://www.ecos.org/) <https://www.ecos.org/>, ECOS paper(DOC) [↗](https://www.ecos.org/documents/risk-assessment-identification-and-selection-of-toxicity-valuescriteria-for-cercla-and-hazardous-waste-site-risk-assessments-in-the-absence-of-iris-values/) <https://www.ecos.org/documents/risk-assessment-identification-and-selection-of-toxicity-valuescriteria-for-cercla-and-hazardous-waste-site-risk-assessments-in-the-absence-of-iris-values/>).

When using toxicity values other than tier 1, users are encouraged to carefully review the basis for the value and to document the basis of toxicity values used on a CERCLA site.

Please contact a Superfund risk assessor in your Region for help with chemicals that lack toxicity values in the sources outlined above.

2.3.1 Reference Doses

The current, or recently completed, EPA toxicity assessments used in these screening tables (IRIS and PPRTVs) define a reference dose, or RfD, as an estimate (with uncertainty spanning perhaps an order of magnitude) of a daily oral exposure to the human population (including sensitive subgroups) that is likely to be without an appreciable risk of deleterious effects during a lifetime. It can be derived from a NOAEL, LOAEL, or benchmark dose, or using categorical regression, with uncertainty factors generally applied to reflect limitations of the data used. RfDs are generally the toxicity value used most often in evaluating noncancer health effects at Superfund sites. Various types of RfDs are available depending on the critical effect (developmental or other) and the length of exposure being evaluated (chronic or subchronic). Some of the SLs in these tables also use Agency for Toxic Substances and Disease Registry (ATSDR) chronic oral minimal risk levels (MRLs) as an oral chronic RfD. Screening toxicity values in an appendix to certain PPRTV assessments were added to the hierarchy in the fall of 2009. The HEAST RfDs used in these SLs were based upon then current EPA toxicity methodologies, but did not use the more recent benchmark dose or categorical regression methodologies. Chronic oral reference doses and ATSDR chronic oral MRLs are expressed in units of (mg/kg-day).

2.3.1.1 Chronic Reference Doses

Chronic oral RfDs are specifically developed to be protective for long-term exposure to a compound. As a guideline for Superfund program risk assessments, chronic oral RfDs generally should be used to evaluate the potential noncarcinogenic effects associated with exposure periods greater than 7 years (approximately 10 percent of a human lifetime). However, this is not a bright line. Note, that ATSDR defines chronic exposure as greater than 1 year for use of their values. The calculator requires the user to select between chronic and subchronic toxicity values.

2.3.1.2 Subchronic Reference Doses

Subchronic oral RfDs are specifically developed to be protective for short-term exposure to a compound. As a guideline for Superfund program risk assessments, subchronic oral RfDs should generally be used to evaluate the potential noncarcinogenic effects of exposure periods between two weeks and seven years. However, this is not a bright line. Note, that ATSDR defines subchronic exposure as less than 1 year for use of their values. The calculator requires the user to select between chronic and subchronic toxicity values.

2.3.2 Reference Concentrations

The current, or recently completed, EPA toxicity assessments used in these screening tables (IRIS and PPRTV assessments) define a reference concentration (RfC) as an estimate (with uncertainty spanning perhaps an order of magnitude) of a continuous inhalation exposure to the human

population (including sensitive subgroups) that is likely to be without an appreciable risk of deleterious effects during a lifetime. It can be derived from a NOAEL, LOAEL, or benchmark concentration, or using categorical regression with uncertainty factors generally applied to reflect limitations of the data used. Various types of RfCs are available depending on the critical effect (developmental or other) and the length of exposure being evaluated (chronic or subchronic). These screening tables also use ATSDR chronic inhalation MRLs as a chronic RfC, intermediate inhalation MRLs as a subchronic RfC and California Environmental Protection Agency (chronic) Reference Exposure Levels (RELs) as chronic RfCs. Screening toxicity values in an appendix to certain PPRTV assessments were added to the hierarchy in the fall of 2009. These screening tables may also use some RfCs from EPA's HEAST tables.

2.3.2.1 Chronic Reference Concentrations

The chronic inhalation reference concentration is generally used for continuous or near continuous inhalation exposures that occur for 7 years or more. However, this is not a bright line, and ATSDR chronic MRLs are based on exposures longer than 1 year. EPA chronic inhalation reference concentrations are expressed in units of (mg/m^3) . Cal EPA RELs are presented in $\mu\text{g}/\text{m}^3$ and have been converted to mg/m^3 for use in these screening tables. Some ATSDR inhalation MRLs are derived in parts per million (ppm) and some in mg/m^3 . For use in this table all were converted into mg/m^3 . The calculator requires the user to select between chronic and subchronic toxicity values.

2.3.2.2 Subchronic reference Concentrations

The subchronic inhalation reference concentration is generally used for exposures that are between 2 weeks and 7 years. However, this is not a bright line, and ATSDR subchronic MRLs are based on exposures less than 1 year. EPA subchronic inhalation reference concentrations are expressed in units of (mg/m^3) . Cal EPA RELs are presented in $\mu\text{g}/\text{m}^3$ and have been converted to mg/m^3 for use in these screening tables. Some ATSDR intermediate inhalation MRLs are derived in parts per million (ppm) and some in mg/m^3 . For use in this table all were converted into mg/m^3 . The calculator requires the user to select between chronic and subchronic toxicity values.

2.3.3 Slope Factors

A slope factor and the accompanying weight-of-evidence determination are the toxicity data most commonly used to evaluate potential human carcinogenic risks. Generally, the slope factor is a plausible upper-bound estimate of the probability of a response per unit intake of a chemical over a lifetime. The slope factor is used in risk assessments to estimate an upper-bound lifetime

probability of an individual developing cancer as a result of exposure to a particular level of a potential carcinogen. Slope factors should always be accompanied by the weight-of-evidence classification to indicate the strength of the evidence that the agent is a human carcinogen.

Oral slope factors are toxicity values for evaluating the probability of an individual developing cancer from oral exposure to contaminant levels over a lifetime. Oral slope factors are expressed in units of $(\text{mg}/\text{kg}\text{-day})^{-1}$. When available, oral slope factors from EPA's IRIS or PPRTV assessments are used. The ATSDR does not derive cancer toxicity values (e.g. slope factors or inhalation unit risks). Some oral slope factors used in these screening tables were derived by the California Environmental Protection Agency, whose methodologies are quite similar to those used by EPA's IRIS and PPRTV assessments. Screening toxicity values in an appendix to certain PPRTV assessments were added to the hierarchy in the fall of 2009. When oral slope factors are not available in IRIS then PPRTVs, Cal EPA assessments, PPRTV appendices or values from HEAST are used.

2.3.4 Inhalation Unit Risk

The IUR is defined as the upper-bound excess lifetime cancer risk estimated to result from continuous exposure to an agent at a concentration of $1 \mu\text{g}/\text{m}^3$ in air. Inhalation unit risk toxicity values are expressed in units of $(\mu\text{g}/\text{m}^3)^{-1}$.

When available, inhalation unit risk values from EPA's IRIS or PPRTV assessments are used. The ATSDR does not derive cancer toxicity values (e.g. slope factors or inhalation unit risks). Some inhalation unit risk values used in these screening tables were derived by the California Environmental Protection Agency, whose methodologies are quite similar to those used by EPA's IRIS and PPRTV assessments. Screening toxicity values in an appendix to certain PPRTV assessments were added to the hierarchy in the fall of 2009. When inhalation unit risk values are not available in IRIS then PPRTVs, Cal EPA assessments, PPRTV appendices or values from HEAST are used.

2.3.5 Toxicity Equivalence Factors (TEF)

Some chemicals are members of the same family and exhibit similar toxicological properties; however, they differ in the degree of toxicity. Therefore, it is recommended that a toxicity equivalence factor (TEF) be applied to the measured concentrations in environmental media to create a toxicity equivalent concentration. In the case of dioxins and furans, the toxicity equivalent concentrations are summed and compared to the 2,3,7,8-TCDD RSL. In the case of the numbered PCBs, the TEF has been applied to the toxicity value, and the measured concentration in environmental media can be compared directly to the RSLs for the individual numbered PCBs.

The following table contains the various dioxin-like toxicity equivalency factors for Dioxins, Furans and dioxin-like PCBs (Van den Berg et al. 2006 (PDF)

<https://semspub.epa.gov/src/document/03/2218791> (19 pp, 290 K)), which are the World Health Organization 2005 values. These TEFs are also presented in the May 2013 fact sheet, " Use of Dioxin TEFs in Calculating Dioxin TEQs at CERCLA and RCRA Sites (PDF)

<https://semspub.epa.gov/src/document/hq/174558>" (8 pp, 105 K) which references the 2010 EPA report, "Recommended Toxicity Equivalence Factors (TEFs) for Human Health Risk Assessments of 2,3,7,8Tetrachlorodibenzo-p-dioxin and Dioxin-Like Compounds (PDF)

<https://semspub.epa.gov/src/document/hq/190077>" (38 pp, 532 K).

Dioxin Toxicity Equivalence Factors

CASRN	Dioxins and Furans	TEF
Chlorinated dibenzo-p-dioxins		
1746-01-6	2,3,7,8-TCDD	1
40321-76-4	1,2,3,7,8-PeCDD	1
39227-28-6	1,2,3,4,7,8-HxCDD	0.1
57653-85-7	1,2,3,6,7,8-HxCDD	0.1
19408-74-3	1,2,3,7,8,9-HxCDD	0.1
35822-46-9	1,2,3,4,6,7,8-HpCDD	0.01
3268-87-9	OCDD	0.0003
Chlorinated dibenzofurans		
51207-31-9	2,3,7,8-TCDF	0.1
57117-41-6	1,2,3,7,8-PeCDF	0.03
57117-31-4	2,3,4,7,8-PeCDF	0.3
70648-26-9	1,2,3,4,7,8-HxCDF	0.1
57117-44-9	1,2,3,6,7,8-HxCDF	0.1
72918-21-9	1,2,3,7,8,9-HxCDF	0.1

CASRN	Dioxins and Furans		TEF
60851-34-5	2,3,4,6,7,8-HxCDF		0.1
67562-39-4	1,2,3,4,6,7,8-HpCDF		0.01
55673-89-7	1,2,3,4,7,8,9-HpCDF		0.01
39001-02-0	OCDF		0.0003
PCBs			
	IUPAC No.	Structure	
<i>Non-ortho</i>			
32598-13-3	77	3,3',4,4'-TetraCB	0.0001
70362-50-4	81	3,4,4',5-TetraCB	0.0003
57465-28-8	126	3,3',4,4',5-PeCB	0.1
32774-16-6	169	3,3',4,4',5,5'-HxCB	0.03
<i>Mono-ortho</i>			
32598-14-4	105	2,3,3',4,4'-PeCB	0.00003
74472-37-0	114	2,3,4,4',5-PeCB	0.00003
31508-00-6	118	2,3',4,4',5-PeCB	0.00003
65510-44-3	123	2',3,4,4',5-PeCB	0.00003
38380-08-4	156	2,3,3',4,4',5-HxCB	0.00003
69782-90-7	157	2,3,3',4,4',5'-HxCB	0.00003
52663-72-6	167	2,3',4,4',5,5'-HxCB	0.00003
39635-31-9	189	2,3,3',4,4',5,5'-HpCB	0.00003
<i>Di-ortho*</i>			
35065-30-6	170	2,2',3,3',4,4',5-HpCB	0.0001

CASRN	Dioxins and Furans		TEF
35065-29-3	180	2,2',3,4,4',5,5'-HpCB	0.00001

* Di-ortho values come from Ahlborg, U.G., et al. (1994), which are the WHO 1994 values from Toxic equivalency factors for dioxin-like PCBs: Report on WHO-ECEH and IPCS consultation, December 1993 Chemosphere, Volume 28, Issue 6, March 1994, Pages 1049-1067 (PDF) <<https://semspub.epa.gov/src/document/03/2218765>> (19 pp, 880 K).

2.3.6 Relative Potency Factors (RPFs)

Some chemicals are members of the same family and exhibit similar toxicological properties; however, they differ in the degree of toxicity. Therefore, a relative potency factor (RPF) must first be applied to adjust the oral slope factor or inhalation unit risk based on the relative potency to the primary compound. In the case of the PAHs, the RPF has been applied to the toxicity value, and the measured concentration in environmental media can be compared directly to the RSLs for the individual PAHs.

Carcinogenic polycyclic aromatic hydrocarbons

Provisional Guidance for Quantitative Risk Assessment of Polycyclic Aromatic Hydrocarbons (EPA/600/R-93/089, July 1993), recommends that a RPF be used to convert concentrations of carcinogenic polycyclic aromatic hydrocarbons (cPAHs) to an equivalent concentration of benzo(a)pyrene when assessing the cancer risks posed by these substances from oral exposures. These RPFs are based on the potency of each compound relative to that of benzo(a)pyrene. For the toxicity value database, these RPFs have been applied to the toxicity values. Although this is not in complete agreement with the direction in the aforementioned documents, this approach was used so that toxicity values could be generated for each cPAH. Additionally, it should be noted that computationally it makes little difference whether the RPFs are applied to the concentrations of cPAHs found in environmental samples or to the toxicity values as long as the RPFs are not applied to both. However, if the adjusted toxicity values are used, the user will need to sum the risks from all cPAHs as part of the risk assessment to derive a total risk from all cPAHs. A total risk from all cPAHs is what is derived when the RPFs are applied to the environmental concentrations of cPAHs and not to the toxicity values. These RPFs are not needed, and should not be used, with the Cal EPA toxicity values, **nor should they be used when calculating non-cancer risk.**

The IRIS Profile <https://iris.epa.gov/chemicallanding/&substance_nmbr=136> gives the following instructions for RPF application:

"It (BaP) also serves as an index chemical for deriving relative potency factors to estimate the carcinogenicity of other PAH congeners, such as in EPA's Relative Potency Factor approach for the assessment of the carcinogenicity of PAHs (U.S. EPA, 1993) (PDF)

<<https://semspub.epa.gov/src/document/hq/100000047>> (28 pp, 1.4 MB)."

and

"The inhalation unit risk for benzo[a]pyrene is derived with the intention that it will be paired with EPA's relative potency factors for the assessment of the carcinogenicity of PAH mixtures. In addition, regarding the assessment of early life exposures, because cancer risk values calculated for benzo[a]pyrene were derived from adult animal exposures, and because benzo[a]pyrene carcinogenicity occurs via a mutagenic mode of action, exposures that occur during development should include the application of ADAFs (see Section 2.5)."

The following table presents the RPFs for cPAHs recommended in Provisional Guidance for Quantitative Risk Assessment of Polycyclic Aromatic Hydrocarbons (PDF)

<<https://semspub.epa.gov/src/document/hq/100000047>> (28 pp, 1.4 MB).

Relative Potency Factors for Carcinogenic Polycyclic Aromatic Hydrocarbons

CASRN	Compound	RPF
50-32-8	Benzo(a)pyrene	1.0
56-55-3	Benz(a)anthracene	0.1
205-99-2	Benzo(b)fluoranthene	0.1
207-08-9	Benzo(k)fluoranthene	0.01
218-01-9	Chrysene	0.001
53-70-3	Dibenz(a,h)anthracene	1.0
193-39-5	Indeno(1,2,3-c,d)pyrene	0.1

2.4 Chemical-specific Parameters

Several chemical specific parameters are needed for development of the RSLs.

2.4.1 Sources

Many sources are used to populate the database of chemical-specific parameters. Major sources are curated as individual data tables and designated by the name of the source (i.e.; PHYSPROP, EPI, CRC, etc.). Minor sources are curated together in an individual data table designated as "Other". The sources are briefly described below.

The major sources are:

1. The Physical Properties Database (PHYSPROP [🔗](https://www.srcinc.com/what-we-do/environmental/scientific-databases.html) <<https://www.srcinc.com/what-we-do/environmental/scientific-databases.html>>) was developed by Syracuse Research Corporation (SRC). The PhysProp database contains chemical structures, names and physical properties for over 41,000 chemicals. Physical properties collected from a wide variety of sources include experimental, extrapolated and estimated values.
2. The Estimation Programs Interface (EPI Suite™ [🔗](https://epa.gov/tsca-screening-tools/epi-suite-tm-estimation-program-interface) <<https://epa.gov/tsca-screening-tools/epi-suite-tm-estimation-program-interface>>) was developed by the US Environmental Protection Agency's Office of Pollution Prevention and Toxics and SRC. These programs estimate various chemical-specific properties. The calculations for these SL tables use the experimental values for a property over the estimated values.
3. CRC Handbook of Chemistry and Physics [🔗](https://hbcponline.com) <<https://hbcponline.com>>. (Various Editions)
4. Perry's Chemical Engineers' Handbook (Various Editions). McGraw-Hill. Online version available here [🔗](https://www.accessengineeringlibrary.com/browse/perrys-chemical-engineers-handbook-eighth-edition) <<https://www.accessengineeringlibrary.com/browse/perrys-chemical-engineers-handbook-eighth-edition>>. Green, Don W.; Perry, Robert H. (2008).
5. Lange's Handbook of Chemistry (Various Editions). Online version available here [🔗](https://accessengineeringlibrary.com/browse/langes-handbook-of-chemistry-sixteenth-edition) <<https://accessengineeringlibrary.com/browse/langes-handbook-of-chemistry-sixteenth-edition>>. Speight, James G. (2005). McGraw-Hill.
6. Yaws' Handbook of Thermodynamic and Physical Properties of Chemical Compounds [🔗](#). Knovel, 2003.
7. EPA Supplemental Guidance for Developing Soil Screening Levels for Superfund Sites (SSL [🔗](https://epa.gov/superfund/superfund-soil-screening-guidance) <<https://epa.gov/superfund/superfund-soil-screening-guidance>>) and Appendix A-C [🔗](https://semspub.epa.gov/src/document/hq/174067.pdf) <<https://semspub.epa.gov/src/document/hq/174067.pdf>> (39 pp, 681 K), "Chemical Properties and Regulatory/Human Health Benchmarks for SSL Calculations". Table C-1: Chemical-Specific Properties used in SSL Calculations and Table C-4: Metal Kd Values (L/kg) as a Function of pH.

8. Summary of Physical/Chemical and Environmental Parameters for PFAS : Subject to Interim Special Order by Consent No. 20-086-CWP/AP/GW/HW/DW/SW, paragraph 37(J)(3). Environmental Studies Report <<https://semspub.epa.gov/src/document/hq/100002785>> E21-0037. 3M, 2021
9. Baes, C.F. 1984. Oak Ridge National Laboratory. A Review and Analysis of Parameters for Assessing Transport of Environmentally Released Radionuclides through Agriculture. Values are also found in Superfund Chemical Data Matrix (SCDM <<https://epa.gov/superfund/superfund-chemical-data-matrix-scdm>>).
10. U.S. EPA 2004. Risk Assessment Guidance for Superfund Volume I: Human Health Evaluation Manual (Part E, Supplemental Guidance for Dermal Risk Assessment) Final. OSWER 9285.7-02EP. July 2004. Document (PDF) <<https://semspub.epa.gov/src/document/hq/195>> (186 pp, 4.2 MB) and website <<https://epa.gov/risk/risk-assessment-guidance-superfund-rags-part-e>>.
11. U.S. EPA 2015 Technical Guide for Assessing and Mitigating the Vapor Intrusion Pathway from Subsurface Vapor Sources to Indoor Air. OSWER Publication 9200.2-154 <<https://epa.gov/vaporintrusion/technical-guide-assessing-and-mitigating-vapor-intrusion-pathway-subsurface-vapor>> and associated calculation spreadsheet (VISL).

Some of the more commonly used minor sources are:

1. The PubChem website published by the National Center for Biotechnology Information, U.S. National Library of Medicine, 8600 Rockville Pike, Bethesda, MD20894, USA.
2. The Hazardous Substance Data Bank (HSDB) [🔗](https://www.nlm.nih.gov/toxnet/index.html) <<https://www.nlm.nih.gov/toxnet/index.html>> website published by the U.S. National Library of Medicine 8600 Rockville Pike, Bethesda, MD 20894 National Institutes of Health, Health & Human Services.
3. CompTox Chemicals Dashboard <<https://comptox.epa.gov/dashboard/>> website published by the US Environmental Protection Agency containing measured and predicted data for 883,000 chemicals.
4. The Agency for Toxic Substances & Disease Registry (ATSDR) [🔗](https://www.atsdr.cdc.gov/toxprofiles/index.asp) <<https://www.atsdr.cdc.gov/toxprofiles/index.asp>> Toxicological Profiles. Agency for Toxic Substances and Disease Registry, 4770 Buford Hwy NE, Atlanta, GA 30341.
5. NIOSH Pocket Guide to Chemical Hazards (NPG [🔗](https://www.cdc.gov/niosh/npg/npg.html) <<https://www.cdc.gov/niosh/npg/npg.html>>), NIOSH Publication No. 97-140, February 2004.

6. WATER9 Version 2.0 <<https://www3.epa.gov/ttn/chief/software/water/index.html>> is the Windows-based wastewater treatment model containing a database listing many organic compounds and procedures for obtaining reports of constituent fates, including air emissions and treatment effectiveness. This program supersedes WATER8, Chem9, and Chemdat8 WATER9.
7. CHEMFATE Database. CHEMFATE is part of the Environmental Fate Data Bases (EFDB) software developed by SRC under sponsorship of the U.S. Environmental Protection Agency. CHEMFATE contains physical property values, rate constants, and monitoring data for approximately 1700 chemicals.
8. The ARS Pesticide Properties Database: U.S. Department of Agriculture, Agricultural Research Service. 2009. Document (PDF) <<https://semspub.epa.gov/src/document/03/2218702>>(393 pp, 775 K) and website [🔗](#).
9. Other sources for esoteric chemicals with sparsely published physicochemical parameters.

2.4.2 Hierarchy by Parameter

The hierarchies below present the major sources in order of selection. Minor sources are interspersed throughout the hierarchies in a collection called "Other". These hierarchies are generally representative of both organic and inorganic compounds. The 3M chemical properties for PFAS is the first source for all parameters for PFAS compounds.

1. Organic Carbon Partition Coefficient (K_{oc}) (L/kg). Not applicable for inorganics. Other; EPI estimated values; SSL, Yaws' estimated values; EPI experimental values; Yaws' Experimental values. The exception to this hierarchy are the nine ionizable organics identified in table 42 of Part 5 of the Soil Screening Guidance Technical Background Document (PDF)

<<https://semspub.epa.gov/src/document/hq/175235.pdf>>(28 pp, 523 K). Appendix L goes into detail on the derivation of these values. The table is reproduced below:

Compound	K_{oc} pH=6.8F
Benzoic acid	0.6
2-chlorophenol	388
2,4-dichlorophenol	147
2,4-dinitrophenol	0.01
pentachlorophenol (PCP)	592
2,3,4,5-tetrachlorophenol	4742
2,3,4,6-tetrachlorophenol	280
2,4,5-trichlorophenol	1597
2,4,6-trichlorophenol	381

2. Dermal Permeability Coefficient (K_p) (cm/hour). EPI estimated values; RAGS Part E estimated value.
3. Effective Predictive Domain (EPD). Calculated based on RAGS Part E criteria for MW and log K_{ow} .
4. Fraction Absorbed (FA). RAGS Part E Exhibit B-3; Calculated. Calculated FA values less than zero are set to zero.
5. Molecular Weight (MW) (g/mole). PHYSPROP; EPI; CRC; Perry's; Lange's; Yaws'; Other.

6. Water Solubility (S) (mg/L at 25 °C, unless otherwise stated in the source). PHYSPROP experimental values; EPI experimental values; CRC; Yaws' experimental values; Perry's; Lange's; PHYSPROP estimated values; Yaws estimated values; EPI estimated values (WATERNT v.1.01, WSKOWWIN v1.42 respectively); Other.
7. Unitless Henry's Law Constant (H' at 25 °C, unless otherwise stated in the source.). PHYSPROP experimental values; EPI experimental values; Yaws' experimental values; CRC; PHYSPROP extrapolated values; PHYSPROP estimated values; EPI group-estimated values; EPI bond-estimated values; Other.
8. Henry's Law Constant (atm-m³/mole at 25 °C, unless otherwise stated in the source). PHYSPROP experimental values; EPI experimental values; Yaws' experimental values; CRC; PHYSPROP extrapolated values; PHYSPROP estimated values; EPI group-estimated values; EPI bond-estimated values; Other.
9. Diffusivity in Air (D_{ia}) (cm²/s). WATER9 equations.
10. Diffusivity in Water (D_{iw}) (cm²/s). WATER9 equations.
11. Fish Bioconcentration Factor (BCF) (L/kg). EPI experimental values; EPI estimated values; Other.
12. Soil-Water Partition Coefficient (K_d) (cm³/g). For inorganics: SSL; BAES; Other. For organics the K_d = f_{oc} × K_{oc} except for PFAS compounds where a K_d may come from the 3M Environmental Studies Report <<https://semspub.epa.gov/src/document/hq/100002785>>.
13. Density (g/cm³). CRC; Perry's; Lange's; Other.
14. Melting Point (MP °C). PHYSPROP experimental values; EPI experimental values; CRC; Perry's; Lange's; Yaws' freezing point; EPI estimated values; Other.
15. log Octanol-Water Partition Coefficient (logKow). PHYSPROP experimental values, EPI experimental values; CRC; Yaws experimental values; PHYSPROP extrapolated; PHYSPROP estimated; EPI estimated values; Yaws estimated values; Other.
16. Vapor Pressure (VP). PHYSPROP experimental values, EPI experimental values; CRC; PHYSPROP extrapolated values; PHYSPROP estimated values; EPI estimated values; Other.
17. Critical Temperature (T_c °K). CRC; Yaws' Experimental; Yaws' Estimated; VISL; Other.
18. Enthalpy of vaporization at the normal boiling point (cal/mol). CRC; VISL; Yaws' extrapolated; Yaws' Estimated.

19. Lower Explosive Limit (LEL). CRC; Yaws' experimental; Yaws' extrapolated; Yaws' estimated; VISL

2.5 Maximum Contaminant Levels (MCLs)

The Safe Drinking Water Act (SDWA <<https://epa.gov/dwstandardsregulations/background-drinking-water-standards-safe-drinking-water-act-sdwa>>) was originally passed by Congress in 1974 to protect public health by regulating the nation's public drinking water supply. SDWA authorizes the United States Environmental Protection Agency (US EPA) to set national health based standards for drinking water to protect against both naturally-occurring and man-made contaminants that may be found in drinking water.

US EPA sets national standards for drinking water based on sound science to protect against health risks, considering available technology and costs. These National Primary Drinking Water Regulations set enforceable maximum contaminant levels (MCLs) for contaminants in drinking water or required ways to treat water to remove contaminants. The MCLs are published here (PDF) <https://epa.gov/sites/production/files/2016-06/documents/npwdr_complete_table.pdf> (6 pp, 924 K). More information can be found in the 2018 Drinking Water Standards and Advisory Tables <<https://epa.gov/system/files/documents/2022-01/dwtable2018.pdf>>. The standards that are set to “treat water to remove contaminants” are Maximum Residual Disinfectant Levels (MRDLs). MRDLs are a specific type of MCL that are equally enforceable. They are presented together in the RLS tables and calculator output under the general term of MCL. The contaminants with MRDLs are: monochloramine, dichloramine, trichloramine, organic chloramine, chlorine, and chlorine dioxide.

US EPA sets primary drinking water standards through a three-step process: First, US EPA identifies contaminants that may adversely affect public health and occur in drinking water with a frequency and at levels that pose a threat to public health. Second, US EPA determines a maximum contaminant level goal (MCLG) for contaminants it decides to regulate. This goal is the level of a contaminant in drinking water below which there is no known or expected risk to health. Third, US EPA specifies a MCL, the maximum permissible level of a contaminant in drinking water which is delivered to any user of a public water system. These levels are enforceable standards, and are set as close to the MCLGs as feasible.

MCLs are provided in the RSL tables and the calculator output for users' information. A few things should be understood about the differences between RSLs and MCLs.

- RSLs are generated by and for the Superfund program, and MCLs are generated by the Office of Water although they are both used by other federal and state programs.

- The RSL calculations may result in a lower concentration than the MCL for a contaminant. The most common reason for this is that the RSLs represent risk-based concentrations considering only the relationship between exposure and risk.
- RSLs are calculated considering ingestion, inhalation, and dermal exposure to tap water.
- MCLs are set as close to risk-based goals, or Maximum Contaminant Level Goal (MCLG), as feasible. MCLGs are non-enforceable public health goals. MCLGs consider only public health and not the limits of detection and treatment technology effectiveness. Conversely, MCLs take the best available analytical and treatment technologies and cost into consideration.
- MCLGs for noncancer effects are based on a Reference Dose and consider ingestion of drinking water with a relative source contribution. The relative source contribution is the percentage of total drinking water exposure for the general population, after considering other exposure routes (for example, food, inhalation).
- For chemical contaminants that are carcinogens, EPA sets the MCLG at zero if: 1) there is evidence that a chemical may cause cancer and 2) there is no dose below which the chemical is considered safe. If a chemical is carcinogenic, and a safe dose can be determined, EPA sets the MCLG at a level above zero that is safe.
- If you have questions about the use of MCLs and/or RSLs at a Superfund site, consult your regional risk assessor.

2.6 Understanding Risk Output on the RSL Website

The RSL calculator provides an option to select risk output. In the calculator, select yes if risk output is desired. Selecting risk output requires the calculator to be run in "Site-Specific" mode. In site-specific mode, the user will be required to enter site concentrations for each media and chemical selected. The "Soil to Groundwater" medium does not have risk output and the risk option will become disabled when selected. The risk and hazard index values presented on this site are chemical-specific values for individual contaminants in air, water, soil, and fish that may warrant further investigation or site cleanup.

This portion of the risk assessment process is generally referred to as "Risk Characterization". This step incorporates the outcome of the exposure and toxicity assessments to calculate the risk resulting from potential exposure to chemicals via the pathways and routes of exposure determined appropriate for the source area.

2.6.1 How Risk is Calculated

The process used to calculate risk (carcinogenic risk and hazard quotient) in this calculator does not follow the traditional method of first calculating a Chronic Daily Intake (CDI). Rather, risk is derived using a simple method that relies on the linear nature of the relationship between

concentration and risk. Using the equation below, an RSL, the target risk or target hazard quotient used to calculate the RSL, and a concentration entered by the user are all that is required to calculate risk.

$$\text{Carcinogenic: } TR / RSL = \text{Risk} / C$$

$$\text{Noncarcinogenic: } THQ / RSL = HQ / C$$

The linear equation above is then rearranged to solve for risk:

$$\text{Carcinogenic: } \text{Risk} = (C \times TR) / RSL$$

$$\text{Noncarcinogenic: } HQ = (C \times THQ) / RSL$$

where:

Risk = a unitless probability of an individual developing cancer over a lifetime, determined with the equation above;

HQ = unitless ratio of exposure concentration to reference concentration where a value less than or equal to unity indicates the exposure is not likely to result in adverse health effects.;

C = Concentration entered by the user in site-specific mode [mg/kg ; $\mu\text{g}/\text{m}^3$; $\mu\text{g}/\text{L}$];

TR = Target Risk provided by the user in site-specific mode;

THQ = Target Hazard Quotient provided by the user in site-specific mode;

RSL = Regional Screening Level, determined by the values entered by the user in site-specific mode [mg/kg ; $\mu\text{g}/\text{m}^3$; $\mu\text{g}/\text{L}$].

2.6.2 One-Hit Rule for Carcinogenic Risk

The linear risk equation, listed above, is valid only at low risk levels (below estimated risks of 0.01). For sites where chemical intakes might be high (estimated risks above 0.01, an alternate calculation should be used. The one-hit equation, which is consistent with the linear low-dose model, should be used instead (RAGS, part A, ch. 8). The results presented use this rule. In the following instances, the one-hit rule is used independently in the risk output tables:

- Risk from a single exposure route for a single chemical.
- Summation of single chemical risk (without one-hit rule applied to single chemical results) for multiple exposure routes (right of each row).
- Summation of risk (without one-hit rule applied to single chemical results) from a single exposure route for multiple chemicals (bottom of each column).
- Summation of total risk (without one-hit rule applied to single chemical results or summations listed above) from multiple chemicals across multiple exposure routes (bottom right hand cell).

3. Understanding Your Superfund Site

The "Generic Tables <<https://epa.gov/risk/regional-screening-levels-rsls-generic-tables>>" page provides generic concentrations in the absence of site-specific exposure assessments. These concentrations can be used for:

- Prioritizing multiple sites or operable units or areas of concern within a facility or exposure units.
- Setting risk-based detection limits for contaminants of potential concern (COPCs).
- Focusing future site investigation and risk assessment efforts (e.g., selecting COPCs for the baseline risk assessment).
- Identifying contamination which may warrant cleanup.
- Identifying sites, or portions of sites, which warrant no further action or investigation.
- Initial cleanup goals when site-specific data are lacking.

Generic SLs are provided for multiple exposure pathways and for chemicals with both carcinogenic and noncarcinogenic effects. The most protective of the carcinogenic and noncarcinogenic values is selected as the RSL. Two sets of summary tables are provided. Both consider a 10^{-6} target cancer risk level; however, one set considers a target hazard quotient of 1.0 and the other considers a target hazard quotient of 0.1. The summary tables identify whether the SL is based on cancer or noncancer effects by including a "c" or "n" after the SL. Site-specific SLs corresponding to an HQ of 0.1 may be appropriate for those sites where multiple chemicals are present that have RfDs or RfCs based on the same toxic endpoint.

Consideration of cumulative noncancer hazard and cumulative cancer risk is important when using the RSLs on a site-specific basis (refer to Section 5.14 and Section 5.15). In general, the site-specific Hazard Index for chemicals with RfDs or RfCs based on the same toxic endpoint should not exceed a value of 1.0 (calculated by summing the Hazard Quotients for individual chemicals). Use of the noncancer RSLs based on a target, Hazard Quotient of 0.1 is recommended for initial screening of sites where more than one chemical with the same toxic endpoint might be present.

The use of RSLs for carcinogens based on a target risk of 10^{-6} for general site screening purposes is normally adequate to address cumulative risk. Site-specific SLs based upon a cancer risk greater than 10^{-6} can be calculated and may be appropriate based upon site-specific considerations. However, caution is recommended to ensure that cumulative cancer risk for all actual and potential carcinogenic contaminants found at the site does not have a residual (after site cleanup, or when it has been determined that no site cleanup is required) cancer risk

exceeding 10^{-4} . Also, changing the target risk or HI may change the balance between the cancer and noncancer endpoints. At some concentrations, the cancer-risk concerns predominate; at other concentrations, noncancer-HI concerns predominate. The user must take care to consider both when adjusting target risks and hazards.

Tables are provided in either MS Excel or in PDF format. The following lists the tables provided and a description of what is contained in each:

- Summary Table - provides a list of contaminants, toxicity values, MCLs and the lesser (more protective) of the cancer and noncancer SLs for resident soil, industrial soil, resident air, industrial air and tapwater.
- Residential Soil Supporting Table - provides a list of contaminants, toxicity values and the cancer and noncancer SLs for resident soil.
- Industrial Soil Supporting Table - provides a list of contaminants, toxicity values and the cancer and noncancer SLs for industrial soil.
- Residential Air Supporting Table - provides a list of contaminants, toxicity values and the cancer and noncancer SLs for resident air.
- Industrial Air Supporting Table - provides a list of contaminants, toxicity values and the cancer and noncancer SLs for industrial air.
- Residential Tapwater Supporting Table - provides a list of contaminants, toxicity values, MCLs and the cancer and noncancer SLs for tapwater.

3.1 Developing a Conceptual Site Model

When using generic SLs at a site, the exposure pathways of concern and site conditions should match those used in developing the SLs presented here. (Note, however, that future uses may not match current uses. Future uses are potential site uses that may occur in the future. At Superfund sites, future uses should be considered as well as current uses. RAGS Part A, Chapter 6, provides guidance on selecting future-use receptors.) Thus, it is necessary to develop a conceptual site model (CSM) to identify likely contaminant source areas, exposure pathways, and potential receptors. This information can be used to determine the applicability of SLs at the site and the need for additional information. The final CSM diagram represents linkages among contaminant sources, release mechanisms, exposure pathways, and routes and receptors based on historical information. It summarizes the understanding of the contamination problem. A separate CSM for ecological receptors can be useful. Part 2 and Attachment A of the Soil Screening Guidance for Superfund: Users Guide (EPA 1996) contains the steps for developing a CSM.

As a final check, the CSM should address the following questions:

- Are there potential ecological concerns?
- Is there potential for land use other than those used in the SL calculations (i.e., residential and commercial/industrial)?
- Are there other likely human exposure pathways that were not considered in development of the SLs?
- Are there unusual site conditions (e.g. large areas of contamination, high fugitive dust levels, potential for indoor air contamination)?

The SLs and later PRGs may need to be adjusted to reflect the answers to these questions.

Below is a potential CSM of the quantified pathways addressed in the SL Tables.

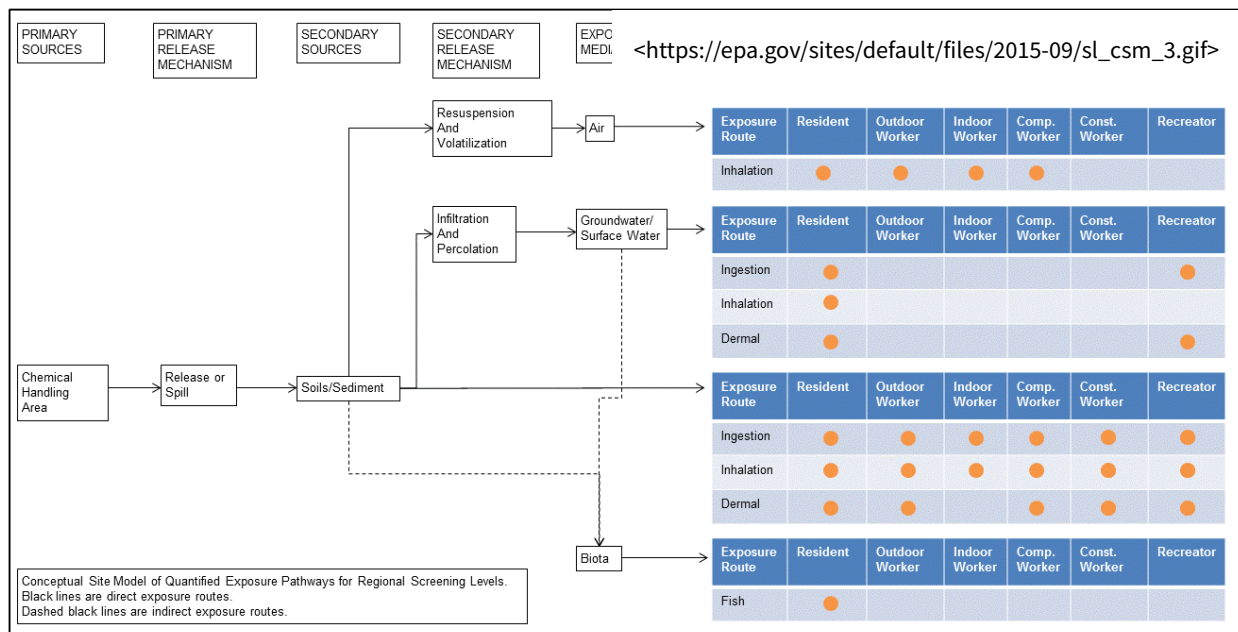

Conceptual Site Model of Quantified Exposure Pathways for Regional Screening Levels. Click image to view full size image.

3.2 Background

EPA may be concerned with two types of background at sites: naturally occurring and anthropogenic. Natural background is usually limited to metals whereas anthropogenic (i.e. human-made) “background” includes both organic and inorganic contaminants.

Please note that the SL tables, which are purely risk-based, may yield SLs lower than naturally occurring background concentrations of some chemicals in some areas. However, background considerations may be incorporated into the assessment and investigation of sites, as acknowledged in existing EPA guidance. Background levels should be addressed as they are for other contaminants at CERCLA sites. For further information see EPA's guidance *Role of Background in the CERCLA Cleanup Program* (PDF) <<https://semspub.epa.gov/src/document/hq/199>> (13 pp, 144 K), April 2002, (OSWER 9285.6-07P) and *Guidance for Comparing Background and Chemical Concentration in Soil for CERCLA Sites* (PDF) <<https://semspub.epa.gov/src/document/hq/112636>> (89 pp, 1.2 MB), September 2002, (OSWER 9285.7-41).

Generally EPA does not clean up below natural background. In some cases, the predictive risk-based models generate SL concentrations that lie within or even below typical background concentrations for the same element or compound. Arsenic, aluminum, iron and manganese are common elements in soils that have background levels that may exceed risk-based SLs. This does not mean that these metals cannot be site-related, or that these metals should automatically be attributed to background. Attribution of chemicals to background is a site-specific decision; consult your regional risk assessor.

Where anthropogenic “background” levels exceed SLs and EPA has determined that a response action is necessary and feasible, EPA's goal will be to develop a comprehensive response to the widespread contamination. This will often require coordination with different authorities that have jurisdiction over the sources of contamination in the area.

3.3 Potential Problems

As with any risk based screening table or tool, the potential exists for misapplication. In most cases, this results from not understanding the intended use of the SLs or PRGs. In order to prevent misuse of the SLs, the following should be avoided:

- Applying SLs to a site without adequately developing a conceptual site model that identifies relevant exposure pathways and exposure scenarios.
- Not considering the effects from the presence of multiple contaminants, where appropriate.
- Use of the SLs as cleanup levels without adequate consideration of the other NCP remedy selection criteria on CERCLA sites.
- Use of SL as cleanup levels without verifying numbers with a toxicologist or regional risk assessor.

- Use of outdated SLs when tables have been superseded by more recent values.
- Not considering the effects of additivity when screening multiple chemicals.
- Applying inappropriate target risks or changing a cancer target risk without considering its effect on noncancer, or vice versa.
- Not performing additional screening for pathways not included in these SLs (e.g., vapor intrusion, fish consumption).
- Adjusting SLs upward by factors of 10 or 100 without consulting a toxicologist or regional risk assessor.

4. Land Use Descriptions, Equations and Technical Documentation

The SLs consider human exposure to individual contaminants in air, drinking water and soil. The equations and technical discussion are aimed at developing risk-based SLs or PRGs. The following text presents the land use equations and their exposure routes. Table 1 presents the definitions of the variables and their default values. Any alternative values or assumptions used in developing SLs on a site should be presented with supporting rationale in the decision document on CERCLA sites.

4.1 Resident

4.1.1 Resident Soil

This receptor spends most, if not all, of the day at home. The activities for this receptor involve typical home making chores (cooking, cleaning and laundering) as well as outdoor activities. The resident is assumed to be exposed to contaminants via the following pathways: incidental ingestion of soil, dermal contact with soil, inhalation of volatiles and fugitive dust. Adults and children exhibit different ingestion rates for soil. For example, the child resident is assumed to ingest 200 mg per day while the adult ingests 100 mg per day. To account for changes in intake as the receptor ages, age adjusted intake equations were developed.

Note that the soil ingestion rates are intended to also represent ingestion of indoor dust. According to U.S. EPA 2011, “The source of the soil in these recommendations could be outdoor soil, indoor containerized soil used to support growth of indoor plants, or a combination of both

outdoor soil and containerized indoor soil. The inhalation and subsequent swallowing of soil particles is accounted for in these recommended values, therefore, this pathway does not need to be considered separately.” Further, according to U.S. EPA 1997, “Although the recommendations presented below are derived from studies which were mostly conducted in the summer, exposure during the winter months when the ground is frozen or snow covered should not be considered as zero. Exposure during these months, although lower than in the summer months, would not be zero because some portion of the house dust comes from outdoor soil.”

This land use is for developing residential default screening levels that are presented in the RSL Generic Tables.

4.1.1.1 Noncarcinogenic-child

The residential soil land use equation, presented here, contains the following exposure routes:

- incidental ingestion of soil

$$SL_{\text{res-sol-ingnc}} \left(\frac{\text{mg}}{\text{kg}} \right) = \frac{\text{THQ} \times \text{AT}_{\text{res-c}} \left(\frac{365 \text{ days}}{\text{yr}} \times \text{ED}_{\text{res-c}} (6 \text{ yr}) \right) \times \text{BW}_{\text{res-c}} (15 \text{ kg})}{\left(\frac{\text{RBA}}{\text{RfD}_o \left(\frac{\text{mg}}{\text{kg-day}} \right)} \right) \times \left(\frac{10^{-6} \text{ kg}}{\text{mg}} \right) \times \text{EF}_{\text{res-c}} \left(\frac{350 \text{ days}}{\text{yr}} \right) \times \text{ED}_{\text{res-c}} (6 \text{ yr}) \times \text{IRS}_{\text{res-c}} \left(\frac{200 \text{ mg}}{\text{day}} \right)}$$

- dermal contact with soil

$$SL_{\text{res-sol-dernc}} \left(\frac{\text{mg}}{\text{kg}} \right) = \frac{\text{THQ} \times \text{AT}_{\text{res-c}} \left(\frac{365 \text{ days}}{\text{yr}} \times \text{ED}_{\text{res-c}} (6 \text{ yr}) \right) \times \text{BW}_{\text{res-c}} (15 \text{ kg})}{\left(\frac{1}{\text{RfD}_o \left(\frac{\text{mg}}{\text{kg-day}} \right) \times \text{GIABS}} \right) \times \left(\frac{10^{-6} \text{ kg}}{\text{mg}} \right) \times \text{EF}_{\text{res-c}} \left(\frac{350 \text{ days}}{\text{yr}} \right) \times \text{ED}_{\text{res-c}} (6 \text{ yr}) \times \text{SA}_{\text{res-c}} \left(\frac{2,373 \text{ cm}^2}{\text{day}} \right) \times \text{AF}_{\text{res-c}} \left(\frac{0.2 \text{ mg}}{\text{cm}^2} \right) \times \text{ABS}_d}$$

- inhalation of volatiles and particulates emitted from soil

$$SL_{\text{res-sol-inhnc}} \left(\frac{\text{mg}}{\text{kg}} \right) = \frac{\text{THQ} \times \text{AT}_{\text{res-c}} \left(\frac{365 \text{ days}}{\text{yr}} \times \text{ED}_{\text{res-c}} (6 \text{ yr}) \right)}{\left(\frac{1}{\text{RFC} \left(\frac{\text{mg}}{\text{m}^3} \right)} \right) \times \text{EF}_{\text{res-c}} \left(\frac{350 \text{ days}}{\text{yr}} \right) \times \text{ED}_{\text{res-c}} (6 \text{ yr}) \times \text{ET}_{\text{res-c}} \left(\frac{24 \text{ hrs}}{\text{day}} \right) \times \left(\frac{1 \text{ day}}{24 \text{ hrs}} \right) \times \left(\frac{1}{\text{VF}_{\text{ulim}} \left(\frac{\text{m}^3}{\text{kg}} \right)} + \frac{1}{\text{PEF} \left(\frac{\text{m}^3}{\text{kg}} \right)} \right)}$$

- Total

$$SL_{\text{res-sol-totnc}} \left(\frac{\text{mg}}{\text{kg}} \right) = \frac{1}{\frac{1}{SL_{\text{res-sol-ingnc}}} + \frac{1}{SL_{\text{res-sol-inhnc}}} + \frac{1}{SL_{\text{res-sol-dernc}}}}$$

4.1.1.2 Noncarcinogenic-adult

The residential soil land use equation, presented here, contains the following exposure routes:

- incidental ingestion of soil

$$SL_{\text{res-sol-ingna}} \left(\frac{\text{mg}}{\text{kg}} \right) = \frac{\text{THQ} \times \text{AT}_{\text{res-a}} \left(\frac{365 \text{ days}}{\text{yr}} \times \text{ED}_{\text{res}} (26 \text{ yr}) \right) \times \text{BW}_{\text{res-a}} (80 \text{ kg})}{\left(\frac{\text{RBA}}{\text{RfD}_o \left(\frac{\text{mg}}{\text{kg-day}} \right)} \right) \times \left(\frac{10^{-6} \text{ kg}}{\text{mg}} \right) \times \text{EF}_{\text{res-a}} \left(\frac{350 \text{ days}}{\text{yr}} \right) \times \text{ED}_{\text{res}} (26 \text{ yr}) \times \text{IRS}_{\text{res-a}} \left(\frac{100 \text{ mg}}{\text{day}} \right)}$$

- dermal contact with soil

$$SL_{\text{res-sol-derna}} \left(\frac{\text{mg}}{\text{kg}} \right) = \frac{\text{THQ} \times \text{AT}_{\text{res-a}} \left(\frac{365 \text{ days}}{\text{yr}} \times \text{ED}_{\text{res}} (26 \text{ yr}) \right) \times \text{BW}_{\text{res-a}} (80 \text{ kg})}{\left(\frac{1}{\text{RfD}_o \left(\frac{\text{mg}}{\text{kg-day}} \right) \times \text{GIABS}} \right) \times \left(\frac{10^{-6} \text{ kg}}{\text{mg}} \right) \times \text{EF}_{\text{res-a}} \left(\frac{350 \text{ days}}{\text{yr}} \right) \times \text{ED}_{\text{res}} (26 \text{ yr}) \times \text{SA}_{\text{res-a}} \left(\frac{6,032 \text{ cm}^2}{\text{day}} \right) \times \text{AF}_{\text{res-a}} \left(\frac{0.07 \text{ mg}}{\text{cm}^2} \right) \times \text{ABS}_d}$$

- inhalation of volatiles and particulates emitted from soil

$$SL_{\text{res-sol-inhna}} \left(\frac{\text{mg}}{\text{kg}} \right) = \frac{\text{THQ} \times \text{AT}_{\text{res-a}} \left(\frac{365 \text{ days}}{\text{yr}} \times \text{ED}_{\text{res}} (26 \text{ yr}) \right)}{\left(\frac{1}{\text{RfC}} \left(\frac{\text{mg}}{\text{m}^3} \right) \right) \times \text{EF}_{\text{res-a}} \left(\frac{350 \text{ days}}{\text{yr}} \right) \times \text{ED}_{\text{res}} (26 \text{ yr}) \times \text{ET}_{\text{res-a}} \left(\frac{24 \text{ hrs}}{\text{day}} \right) \times \left(\frac{1 \text{ day}}{24 \text{ hrs}} \right) \times \left(\frac{1}{\text{VF}_{\text{ulim}} \left(\frac{\text{m}^3}{\text{kg}} \right)} + \frac{1}{\text{PEF}} \left(\frac{\text{m}^3}{\text{kg}} \right)} \right)}$$

- Total

$$SL_{\text{res-sol-totna}} \left(\frac{\text{mg}}{\text{kg}} \right) = \frac{1}{\frac{1}{SL_{\text{res-sol-ingna}}} + \frac{1}{SL_{\text{res-sol-inhna}}} + \frac{1}{SL_{\text{res-sol-derna}}}}$$

4.1.1.3 Carcinogenic

The residential soil land use equation, presented here, contains the following exposure routes:

- incidental ingestion of soil

$$SL_{\text{res-sol-ingc}} \left(\frac{\text{mg}}{\text{kg}} \right) = \frac{TR \times AT_{\text{res}} \left(\frac{365 \text{ days}}{\text{yr}} \times LT(70 \text{ yrs}) \right)}{CSF_o \left(\frac{\text{mg}}{\text{kg-day}} \right)^{-1} \times \left(\frac{10^{-6} \text{ kg}}{\text{mg}} \right) \times RBA \times IFS_{\text{res-adj}} \left(\frac{36,750 \text{ mg}}{\text{kg}} \right)}$$

where:

$$IFS_{\text{res-adj}} \left(\frac{36,750 \text{ mg}}{\text{kg}} \right) = \left[\frac{EF_{\text{res-c}} \left(\frac{350 \text{ days}}{\text{yr}} \right) \times ED_{\text{res-c}}(6 \text{ yr}) \times IRS_{\text{res-c}} \left(\frac{200 \text{ mg}}{\text{day}} \right)}{BW_{\text{res-c}}(15 \text{ kg})} + \frac{EF_{\text{res-a}} \left(\frac{350 \text{ days}}{\text{yr}} \right) \times ED_{\text{res-a}}(20 \text{ yr}) \times IRS_{\text{res-a}} \left(\frac{100 \text{ mg}}{\text{day}} \right)}{BW_{\text{res-a}}(80 \text{ kg})} \right]$$

- dermal contact with soil

$$SL_{\text{res-sol-derc}} \left(\frac{\text{mg}}{\text{kg}} \right) = \frac{TR \times AT_{\text{res}} \left(\frac{365 \text{ days}}{\text{yr}} \times LT(70 \text{ yrs}) \right)}{\left(\frac{CSF_o \left(\frac{\text{mg}}{\text{kg-day}} \right)^{-1}}{GIABS} \right) \times \left(\frac{10^{-6} \text{ kg}}{\text{mg}} \right) \times DFS_{\text{res-adj}} \left(\frac{103,390 \text{ mg}}{\text{kg}} \right) \times ABS_d}$$

where:

$$DFS_{\text{res-adj}} \left(\frac{103,390 \text{ mg}}{\text{kg}} \right) = \left[\frac{EF_{\text{res-c}} \left(\frac{350 \text{ days}}{\text{yr}} \right) \times ED_{\text{res-c}}(6 \text{ yr}) \times SA_{\text{res-c}} \left(\frac{2,373 \text{ cm}^2}{\text{day}} \right) \times AF_{\text{res-c}} \left(\frac{0.2 \text{ mg}}{\text{cm}^2} \right)}{BW_{\text{res-c}}(15 \text{ kg})} + \frac{EF_{\text{res-a}} \left(\frac{350 \text{ days}}{\text{yr}} \right) \times ED_{\text{res-a}}(20 \text{ yr}) \times SA_{\text{res-a}} \left(\frac{6,032 \text{ cm}^2}{\text{day}} \right) \times AF_{\text{res-a}} \left(\frac{0.07 \text{ mg}}{\text{cm}^2} \right)}{BW_{\text{res-a}}(80 \text{ kg})} \right]$$

- inhalation of volatiles and particulates emitted from soil

$$SL_{\text{res-sol-inhc}} \left(\frac{\text{mg}}{\text{kg}} \right) = \frac{TR \times AT_{\text{res}} \left(\frac{365 \text{ days}}{\text{yr}} \times LT(70 \text{ yrs}) \right)}{IUR \left(\frac{\mu\text{g}}{\text{m}^3} \right)^{-1} \times \left(\frac{1000 \mu\text{g}}{\text{mg}} \right) \times EF_{\text{res}} \left(\frac{350 \text{ days}}{\text{yr}} \right) \times ED_{\text{res}}(26 \text{ yr}) \times ET_{\text{res}} \left(\frac{24 \text{ hrs}}{\text{day}} \right) \times \left(\frac{1 \text{ day}}{24 \text{ hrs}} \right) \times \left(\frac{1}{VF_{\text{ulim}} \left(\frac{\text{m}^3}{\text{kg}} \right)} + \frac{1}{PEF \left(\frac{\text{m}^3}{\text{kg}} \right)} \right)}$$

- Total

$$SL_{\text{res-sol-totc}} \left(\frac{\text{mg}}{\text{kg}} \right) = \frac{1}{\frac{1}{SL_{\text{res-sol-ingc}}} + \frac{1}{SL_{\text{res-sol-inhc}}} + \frac{1}{SL_{\text{res-sol-derc}}}}$$

4.1.1.4 Mutagenic

The residential soil land use equation, presented here, contains the following exposure routes:

- incidental ingestion of soil

$$SL_{\text{res-sol-ingmu}} \left(\frac{\text{mg}}{\text{kg}} \right) = \frac{TR \times AT_{\text{res}} \left(\frac{365 \text{ days}}{\text{yr}} \times LT(70 \text{ yrs}) \right)}{CSF_0 \left(\frac{\text{mg}}{\text{kg-day}} \right)^{-1} \times \left(\frac{10^{-6} \text{ kg}}{\text{mg}} \right) \times RBA \times IFSM_{\text{res-adj}} \left(\frac{166,833.3 \text{ mg}}{\text{kg}} \right)}$$

where:

$$IFSM_{\text{res-adj}} \left(\frac{166,833.3 \text{ mg}}{\text{kg}} \right) = \left[\begin{array}{l} \frac{EF_{0-2} \left(\frac{350 \text{ days}}{\text{yr}} \right) \times ED_{0-2} (2 \text{ yr}) \times IRS_{0-2} \left(\frac{200 \text{ mg}}{\text{day}} \right) \times 10}{BW_{0-2} (15 \text{ kg})} + \\ \frac{EF_{2-6} \left(\frac{350 \text{ days}}{\text{yr}} \right) \times ED_{2-6} (4 \text{ yr}) \times IRS_{2-6} \left(\frac{200 \text{ mg}}{\text{day}} \right) \times 3}{BW_{2-6} (15 \text{ kg})} + \\ \frac{EF_{6-16} \left(\frac{350 \text{ days}}{\text{yr}} \right) \times ED_{6-16} (10 \text{ yr}) \times IRS_{6-16} \left(\frac{100 \text{ mg}}{\text{day}} \right) \times 3}{BW_{6-16} (80 \text{ kg})} + \\ \frac{EF_{16-26} \left(\frac{350 \text{ days}}{\text{yr}} \right) \times ED_{16-26} (10 \text{ yr}) \times IRS_{16-26} \left(\frac{100 \text{ mg}}{\text{day}} \right) \times 1}{BW_{16-26} (80 \text{ kg})} \end{array} \right]$$

- dermal contact with soil

$$SL_{\text{res-sol-dermu}} \left(\frac{\text{mg}}{\text{kg}} \right) = \frac{TR \times AT_{\text{res}} \left(\frac{365 \text{ days}}{\text{yr}} \times LT(70 \text{ yrs}) \right)}{\left(\frac{CSF_0 \left(\frac{\text{mg}}{\text{kg-day}} \right)^{-1}}{GIABS} \right) \times \left(\frac{10^{-6} \text{ kg}}{\text{mg}} \right) \times DFSM_{\text{res-adj}} \left(\frac{428,260 \text{ mg}}{\text{kg}} \right) \times ABS_d}$$

where:

$$DFSM_{\text{res-adj}} \left(\frac{428,260 \text{ mg}}{\text{kg}} \right) = \left[\begin{aligned} & \frac{EF_{0-2} \left(\frac{350 \text{ days}}{\text{yr}} \right) \times ED_{0-2} (2 \text{ yr}) \times SA_{0-2} \left(\frac{2,373 \text{ cm}^2}{\text{day}} \right) \times AF_{0-2} \left(\frac{0.2 \text{ mg}}{\text{cm}^2} \right) \times 10}{BW_{0-2} (15 \text{ kg})} + \\ & \frac{EF_{2-6} \left(\frac{350 \text{ days}}{\text{yr}} \right) \times ED_{2-6} (4 \text{ yr}) \times SA_{2-6} \left(\frac{2,373 \text{ cm}^2}{\text{day}} \right) \times AF_{2-6} \left(\frac{0.2 \text{ mg}}{\text{cm}^2} \right) \times 3}{BW_{2-6} (15 \text{ kg})} + \\ & \frac{EF_{6-16} \left(\frac{350 \text{ days}}{\text{yr}} \right) \times ED_{6-16} (10 \text{ yr}) \times SA_{6-16} \left(\frac{6,032 \text{ cm}^2}{\text{day}} \right) \times AF_{6-16} \left(\frac{0.07 \text{ mg}}{\text{cm}^2} \right) \times 3}{BW_{6-16} (80 \text{ kg})} + \\ & \frac{EF_{16-26} \left(\frac{350 \text{ days}}{\text{yr}} \right) \times ED_{16-26} (10 \text{ yr}) \times SA_{16-26} \left(\frac{6,032 \text{ cm}^2}{\text{day}} \right) \times AF_{16-26} \left(\frac{0.07 \text{ mg}}{\text{cm}^2} \right) \times 1}{BW_{16-26} (80 \text{ kg})} \end{aligned} \right]$$

- inhalation of volatiles and particulates emitted from soil

$$SL_{\text{res-sol-inhmu}} \left(\frac{\text{mg}}{\text{kg}} \right) = \frac{TR \times AT_{\text{res}} \left(\frac{365 \text{ days}}{\text{yr}} \times LT(70 \text{ yrs}) \right)}{IUR \left(\frac{\mu\text{g}}{\text{m}^3} \right)^{-1} \times \left(\frac{1000 \mu\text{g}}{\text{mg}} \right) \times \left(\frac{1}{VF_{\text{ulim}} \left(\frac{\text{m}^3}{\text{kg}} \right)} + \frac{1}{PEF \left(\frac{\text{m}^3}{\text{kg}} \right)} \right) \times \left[\begin{aligned} & \left(EF_{0-2} \left(\frac{350 \text{ days}}{\text{yr}} \right) \times ED_{0-2} (2 \text{ yr}) \times ET_{0-2} \left(\frac{24 \text{ hrs}}{\text{day}} \right) \times \left(\frac{1 \text{ day}}{24 \text{ hrs}} \right) \times 10 \right) + \\ & \left(EF_{2-6} \left(\frac{350 \text{ days}}{\text{yr}} \right) \times ED_{2-6} (4 \text{ yr}) \times ET_{2-6} \left(\frac{24 \text{ hrs}}{\text{day}} \right) \times \left(\frac{1 \text{ day}}{24 \text{ hrs}} \right) \times 3 \right) + \\ & \left(EF_{6-16} \left(\frac{350 \text{ days}}{\text{yr}} \right) \times ED_{6-16} (10 \text{ yr}) \times ET_{6-16} \left(\frac{24 \text{ hrs}}{\text{day}} \right) \times \left(\frac{1 \text{ day}}{24 \text{ hrs}} \right) \times 3 \right) + \\ & \left(EF_{16-26} \left(\frac{350 \text{ days}}{\text{yr}} \right) \times ED_{16-26} (10 \text{ yr}) \times ET_{16-26} \left(\frac{24 \text{ hrs}}{\text{day}} \right) \times \left(\frac{1 \text{ day}}{24 \text{ hrs}} \right) \times 1 \right) \end{aligned} \right]}$$

- Total

$$SL_{\text{res-sol-totmu}} \left(\frac{\text{mg}}{\text{kg}} \right) = \frac{1}{\frac{1}{SL_{\text{res-sol-ingmu}}} + \frac{1}{SL_{\text{res-sol-inhmu}}} + \frac{1}{SL_{\text{res-sol-dermu}}}}$$

4.1.1.5 Vinyl Chloride - Carcinogenic

The residential soil land use equations, presented here, contain the following exposure routes:

- incidental ingestion of soil

$$SL_{\text{res-sol-ingvc}} \left(\frac{\text{mg}}{\text{kg}} \right) = \frac{\text{TR}}{\left(\left(\frac{\text{CSF}_o \left(\frac{\text{mg}}{\text{kg-day}} \right)^{-1} \times \left(\frac{10^{-6} \text{ kg}}{\text{mg}} \right) \times \text{RBA} \times \text{IFS}_{\text{res-adj}} \left(\frac{36,750 \text{ mg}}{\text{kg}} \right)}{\text{AT}_{\text{res}} \left(\frac{365 \text{ days}}{\text{yr}} \times \text{LT} (70 \text{ yrs}) \right)} \right) + \left(\frac{\text{CSF}_o \left(\frac{\text{mg}}{\text{kg-day}} \right)^{-1} \times \left(\frac{10^{-6} \text{ kg}}{\text{mg}} \right) \times \text{RBA} \times \text{IRS}_{\text{res-c}} \left(\frac{200 \text{ mg}}{\text{day}} \right)}{\text{BW}_{\text{res-c}} (15 \text{ kg})} \right) \right)}$$

where:

$$\text{IFS}_{\text{res-adj}} \left(\frac{36,750 \text{ mg}}{\text{kg}} \right) = \left[\frac{\text{EF}_{\text{res-c}} \left(\frac{350 \text{ days}}{\text{yr}} \right) \times \text{ED}_{\text{res-c}} (6 \text{ yr}) \times \text{IRS}_{\text{res-c}} \left(\frac{200 \text{ mg}}{\text{day}} \right)}{\text{BW}_{\text{res-c}} (15 \text{ kg})} + \frac{\text{EF}_{\text{res-a}} \left(\frac{350 \text{ days}}{\text{yr}} \right) \times \text{ED}_{\text{res-a}} (20 \text{ yr}) \times \text{IRS}_{\text{res-a}} \left(\frac{100 \text{ mg}}{\text{day}} \right)}{\text{BW}_{\text{res-a}} (80 \text{ kg})} \right]$$

- dermal contact with soil

$$SL_{\text{res-sol-dervc}} \left(\frac{\text{mg}}{\text{kg}} \right) = \frac{\text{TR}}{\left(\frac{\left(\frac{\text{CSF}_o \left(\frac{\text{mg}}{\text{kg-day}} \right)^{-1}}{\text{GIABS}} \times \left(\frac{10^{-6} \text{ kg}}{\text{mg}} \right) \times \text{DFS}_{\text{res-adj}} \left(\frac{103,390 \text{ mg}}{\text{kg}} \right) \times \text{ABS}_d \right)}{\text{AT}_{\text{res}} \left(\frac{365 \text{ days}}{\text{yr}} \times \text{LT} (70 \text{ yrs}) \right)} + \frac{\left(\frac{\text{CSF}_o \left(\frac{\text{mg}}{\text{kg-day}} \right)^{-1}}{\text{GIABS}} \times \left(\frac{10^{-6} \text{ kg}}{\text{mg}} \right) \times \text{SA}_{\text{res-c}} \left(\frac{2,373 \text{ cm}^2}{\text{day}} \right) \times \text{AF}_{\text{res-c}} \left(\frac{0.2 \text{ mg}}{\text{cm}^2} \right) \times \text{ABS}_d \right)}{\text{BW}_{\text{res-c}} (15 \text{ kg})} \right)}$$

where:

$$\text{DFS}_{\text{res-adj}} \left(\frac{103,390 \text{ mg}}{\text{kg}} \right) = \frac{\left(\frac{\text{EF}_{\text{res-c}} \left(\frac{350 \text{ days}}{\text{yr}} \right) \times \text{ED}_{\text{res-c}} (6 \text{ yr}) \times \text{SA}_{\text{res-c}} \left(\frac{2,373 \text{ cm}^2}{\text{day}} \right) \times \text{AF}_{\text{res-c}} \left(\frac{0.2 \text{ mg}}{\text{cm}^2} \right)}{\text{BW}_{\text{res-c}} (15 \text{ kg})} + \frac{\text{EF}_{\text{res-a}} \left(\frac{350 \text{ days}}{\text{yr}} \right) \times \text{ED}_{\text{res-a}} (20 \text{ yr}) \times \text{SA}_{\text{res-a}} \left(\frac{6,032 \text{ cm}^2}{\text{day}} \right) \times \text{AF}_{\text{res-a}} \left(\frac{0.07 \text{ mg}}{\text{cm}^2} \right)}{\text{BW}_{\text{res-a}} (80 \text{ kg})} \right)}$$

- inhalation of volatiles and particulates emitted from soil

$$SL_{\text{res-sol-inhvc}} \left(\frac{\text{mg}}{\text{kg}} \right) = \frac{\text{TR}}{\left(\frac{\left(\frac{\text{IUR} \left(\frac{\mu\text{g}}{\text{m}^3} \right)^{-1}}{\text{mg}} \right) \times \left(\frac{1000 \mu\text{g}}{\text{mg}} \right) \times \text{EF}_{\text{res}} \left(\frac{350 \text{ days}}{\text{yr}} \right) \times \text{ED}_{\text{res}} (26 \text{ yr}) \times \text{ET}_{\text{res}} \left(\frac{24 \text{ hrs}}{\text{day}} \right) \times \left(\frac{1 \text{ day}}{24 \text{ hrs}} \right)}{\text{AT}_{\text{res}} \left(\frac{365 \text{ days}}{\text{yr}} \times \text{LT} (70 \text{ yrs}) \right) \times \text{VF}_{\text{ulim}} \left(\frac{\text{m}^3}{\text{kg}} \right)} + \frac{\left(\frac{\text{IUR} \left(\frac{\mu\text{g}}{\text{m}^3} \right)^{-1}}{\text{VF}_{\text{ulim}} \left(\frac{\text{m}^3}{\text{kg}} \right)} \times \left(\frac{1000 \mu\text{g}}{\text{mg}} \right) \right)}{\right)}$$

- Total

$$SL_{\text{res-sol-totvc}} \left(\frac{\text{mg}}{\text{kg}} \right) = \frac{1}{\frac{1}{SL_{\text{res-sol-ingvc}}} + \frac{1}{SL_{\text{res-sol-inhvc}}} + \frac{1}{SL_{\text{res-sol-dervc}}}}$$

4.1.1.6 Trichloroethylene - Carcinogenic and Mutagenic

The residential soil land use equations, presented here, contain the following exposure routes:

- incidental ingestion of soil

$$SL_{res-sol-ingtce} \left(\frac{mg}{kg} \right) = \frac{TR \times AT_{res} \left(\frac{365 \text{ days}}{yr} \times LT(70 \text{ yrs}) \right)}{CSF_o \left(\frac{mg}{kg-day} \right)^{-1} \times \left(\frac{10^{-6} \text{ kg}}{mg} \right) \times RBA \times \left(\left(CAF_o(0.804) \times IFS_{res-adj} \left(\frac{36,750 \text{ mg}}{kg} \right) \right) + \left(MAF_o(0.202) \times IFSM_{res-adj} \left(\frac{166,833.3 \text{ mg}}{kg} \right) \right) \right)}$$

where:

$$IFS_{res-adj} \left(\frac{36,750 \text{ mg}}{kg} \right) = \left[\frac{EF_{res-c} \left(\frac{350 \text{ days}}{yr} \right) \times ED_{res-c}(6 \text{ yr}) \times IRS_{res-c} \left(\frac{200 \text{ mg}}{day} \right)}{BW_{res-c} (15 \text{ kg})} + \frac{EF_{res-a} \left(\frac{350 \text{ days}}{yr} \right) \times ED_{res-a}(20 \text{ yr}) \times IRS_{res-a} \left(\frac{100 \text{ mg}}{day} \right)}{BW_{res-a} (80 \text{ kg})} \right]$$

and:

$$IFSM_{res-adj} \left(\frac{166,833.3 \text{ mg}}{kg} \right) = \left[\frac{EF_{0-2} \left(\frac{350 \text{ days}}{yr} \right) \times ED_{0-2}(2 \text{ yr}) \times IRS_{0-2} \left(\frac{200 \text{ mg}}{day} \right) \times 10}{BW_{0-2} (15 \text{ kg})} + \frac{EF_{2-6} \left(\frac{350 \text{ days}}{yr} \right) \times ED_{2-6}(4 \text{ yr}) \times IRS_{2-6} \left(\frac{200 \text{ mg}}{day} \right) \times 3}{BW_{2-6} (15 \text{ kg})} + \frac{EF_{6-16} \left(\frac{350 \text{ days}}{yr} \right) \times ED_{6-16}(10 \text{ yr}) \times IRS_{6-16} \left(\frac{100 \text{ mg}}{day} \right) \times 3}{BW_{6-16} (80 \text{ kg})} + \frac{EF_{16-26} \left(\frac{350 \text{ days}}{yr} \right) \times ED_{16-26}(10 \text{ yr}) \times IRS_{16-26} \left(\frac{100 \text{ mg}}{day} \right) \times 1}{BW_{16-26} (80 \text{ kg})} \right]$$

- dermal contact with soil

$$SL_{\text{res-sol-derm}} \left(\frac{\text{mg}}{\text{kg}} \right) = \frac{TR \times AT_{\text{res}} \left(\frac{365 \text{ days}}{\text{yr}} \times LT(70 \text{ yrs}) \right)}{\left(\frac{CSF_o \left(\frac{\text{mg}}{\text{kg-day}} \right)^{-1}}{GIABS} \right) \times \left(\frac{10^{-6} \text{ kg}}{\text{mg}} \right) \times \left(\left(CAF_o(0.804) \times DFS_{\text{res-adj}} \left(\frac{103,390 \text{ mg}}{\text{kg}} \right) \times ABS_d \right) + \left(MAF_o(0.202) \times DFSM_{\text{res-adj}} \left(\frac{428,260 \text{ mg}}{\text{kg}} \right) \times ABS_d \right) \right)}$$

where:

$$DFS_{\text{res-adj}} \left(\frac{103,390 \text{ mg}}{\text{kg}} \right) = \left[\frac{EF_{\text{res-c}} \left(\frac{350 \text{ days}}{\text{yr}} \right) \times ED_{\text{res-c}}(6 \text{ yr}) \times SA_{\text{res-c}} \left(\frac{2,373 \text{ cm}^2}{\text{day}} \right) \times AF_{\text{res-c}} \left(\frac{0.2 \text{ mg}}{\text{cm}^2} \right)}{BW_{\text{res-c}}(15 \text{ kg})} + \frac{EF_{\text{res-a}} \left(\frac{350 \text{ days}}{\text{yr}} \right) \times ED_{\text{res-a}}(20 \text{ yr}) \times SA_{\text{res-a}} \left(\frac{6,032 \text{ cm}^2}{\text{day}} \right) \times AF_{\text{res-a}} \left(\frac{0.07 \text{ mg}}{\text{cm}^2} \right)}{BW_{\text{res-a}}(80 \text{ kg})} \right]$$

and:

$$DFSM_{\text{res-adj}} \left(\frac{428,260 \text{ mg}}{\text{kg}} \right) = \left[\frac{EF_{0-2} \left(\frac{350 \text{ days}}{\text{yr}} \right) \times ED_{0-2}(2 \text{ yr}) \times SA_{0-2} \left(\frac{2,373 \text{ cm}^2}{\text{day}} \right) \times AF_{0-2} \left(\frac{0.2 \text{ mg}}{\text{cm}^2} \right) \times 10}{BW_{0-2}(15 \text{ kg})} + \frac{EF_{2-6} \left(\frac{350 \text{ days}}{\text{yr}} \right) \times ED_{2-6}(4 \text{ yr}) \times SA_{2-6} \left(\frac{2,373 \text{ cm}^2}{\text{day}} \right) \times AF_{2-6} \left(\frac{0.2 \text{ mg}}{\text{cm}^2} \right) \times 3}{BW_{2-6}(15 \text{ kg})} + \frac{EF_{6-16} \left(\frac{350 \text{ days}}{\text{yr}} \right) \times ED_{6-16}(10 \text{ yr}) \times SA_{6-16} \left(\frac{6,032 \text{ cm}^2}{\text{day}} \right) \times AF_{6-16} \left(\frac{0.07 \text{ mg}}{\text{cm}^2} \right) \times 3}{BW_{6-16}(80 \text{ kg})} + \frac{EF_{16-26} \left(\frac{350 \text{ days}}{\text{yr}} \right) \times ED_{16-26}(10 \text{ yr}) \times SA_{16-26} \left(\frac{6,032 \text{ cm}^2}{\text{day}} \right) \times AF_{16-26} \left(\frac{0.07 \text{ mg}}{\text{cm}^2} \right) \times 1}{BW_{16-26}(80 \text{ kg})} \right]$$

- inhalation of volatiles and particulates emitted from soil

$$SL_{\text{res-sol-inhtce}} \left(\frac{\text{mg}}{\text{kg}} \right) = \frac{\text{TR} \times \text{AT}_{\text{res}} \left(\frac{365 \text{ days}}{\text{yr}} \times \text{LT} (70 \text{ yrs}) \right)}{\text{IUR} \left(\frac{\mu\text{g}}{\text{m}^3} \right)^{-1} \times \left(\frac{1000 \mu\text{g}}{\text{mg}} \right) \times \left(\frac{1}{\text{VF}_{\text{ulim}} \left(\frac{\text{m}^3}{\text{kg}} \right)} + \frac{1}{\text{PEF} \left(\frac{\text{m}^3}{\text{kg}} \right)} \right) \times \left[\begin{aligned} & \left(\text{EF}_{\text{res}} \left(\frac{350 \text{ days}}{\text{yr}} \right) \times \text{ED}_{\text{res}} (26 \text{ yr}) \times \text{ET}_{\text{res}} \left(\frac{24 \text{ hrs}}{\text{day}} \right) \times \left(\frac{1 \text{ day}}{24 \text{ hrs}} \right) \times \text{CAF}_i (0.756) \right) + \\ & \left(\text{EF}_{0-2} \left(\frac{350 \text{ days}}{\text{yr}} \right) \times \text{ED}_{0-2} (2 \text{ yr}) \times \text{ET}_{0-2} \left(\frac{24 \text{ hrs}}{\text{day}} \right) \times \left(\frac{1 \text{ day}}{24 \text{ hrs}} \right) \times \text{MAF}_i (0.244) \times 10 \right) + \\ & \left(\text{EF}_{2-6} \left(\frac{350 \text{ days}}{\text{yr}} \right) \times \text{ED}_{2-6} (4 \text{ yr}) \times \text{ET}_{2-6} \left(\frac{24 \text{ hrs}}{\text{day}} \right) \times \left(\frac{1 \text{ day}}{24 \text{ hrs}} \right) \times \text{MAF}_i (0.244) \times 3 \right) + \\ & \left(\text{EF}_{6-16} \left(\frac{350 \text{ days}}{\text{yr}} \right) \times \text{ED}_{6-16} (10 \text{ yr}) \times \text{ET}_{6-16} \left(\frac{24 \text{ hrs}}{\text{day}} \right) \times \left(\frac{1 \text{ day}}{24 \text{ hrs}} \right) \times \text{MAF}_i (0.244) \times 3 \right) + \\ & \left(\text{EF}_{16-26} \left(\frac{350 \text{ days}}{\text{yr}} \right) \times \text{ED}_{16-26} (10 \text{ yr}) \times \text{ET}_{16-26} \left(\frac{24 \text{ hrs}}{\text{day}} \right) \times \left(\frac{1 \text{ day}}{24 \text{ hrs}} \right) \times \text{MAF}_i (0.244) \times 1 \right) \end{aligned} \right]}$$

- Total.

$$SL_{\text{res-sol-tottce}} \left(\frac{\text{mg}}{\text{kg}} \right) = \frac{1}{\frac{1}{SL_{\text{res-sol-ingtce}}} + \frac{1}{SL_{\text{res-sol-inhtce}}} + \frac{1}{SL_{\text{res-sol-dertce}}}}$$

A number of studies have shown that inadvertent ingestion of soil is common among children 6 years old and younger (Calabrese et al. 1989, Davis et al. 1990, Van Wijnen et al. 1990). Therefore, the dose method uses an age-adjusted soil ingestion factor that takes into account the difference in daily soil ingestion rates, body weights, and exposure duration for children from 1 to 6 years old and others from 7 to 26 years old. The equation is presented below. This health-protective approach is chosen to take into account the higher daily rates of soil ingestion in children as well as the longer duration of exposure that is anticipated for a long-term resident. For more on this method, see RAGS Part B <<https://epa.gov/risk/risk-assessment-guidance-superfund-rags-part-b>>.

4.1.1.7 Supporting Equations

- Child

$$ED_{\text{res-c}}(6 \text{ yr}) = ED_{0-2}(2 \text{ yr}) + ED_{2-6}(4 \text{ yr})$$

$$BW_{\text{res-c}}(15 \text{ kg}) = \frac{ED_{0-2}(2 \text{ yr}) \times BW_{0-2}(15 \text{ kg}) + ED_{2-6}(4 \text{ yr}) \times BW_{2-6}(15 \text{ kg})}{ED_{0-2}(2 \text{ yr}) + ED_{2-6}(4 \text{ yr})}$$

$$EF_{\text{res-c}}\left(\frac{350 \text{ days}}{\text{yr}}\right) = \frac{ED_{0-2}(2 \text{ yr}) \times EF_{0-2}\left(\frac{350 \text{ days}}{\text{yr}}\right) + ED_{2-6}(4 \text{ yr}) \times EF_{2-6}\left(\frac{350 \text{ days}}{\text{yr}}\right)}{ED_{0-2}(2 \text{ yr}) + ED_{2-6}(4 \text{ yr})}$$

$$ET_{\text{res-c}}\left(\frac{24 \text{ hrs}}{\text{day}}\right) = \frac{ED_{0-2}(2 \text{ yr}) \times ET_{0-2}\left(\frac{24 \text{ hrs}}{\text{day}}\right) + ED_{2-6}(4 \text{ yr}) \times ET_{2-6}\left(\frac{24 \text{ hrs}}{\text{day}}\right)}{ED_{0-2}(2 \text{ yr}) + ED_{2-6}(4 \text{ yr})}$$

$$AF_{\text{res-c}}\left(\frac{0.2 \text{ mg}}{\text{cm}^2}\right) = \frac{ED_{0-2}(2 \text{ yr}) \times AF_{0-2}\left(\frac{0.2 \text{ mg}}{\text{cm}^2}\right) + ED_{2-6}(4 \text{ yr}) \times AF_{2-6}\left(\frac{0.2 \text{ mg}}{\text{cm}^2}\right)}{ED_{0-2}(2 \text{ yr}) + ED_{2-6}(4 \text{ yr})}$$

$$SA_{\text{res-c}}\left(\frac{2,373 \text{ cm}^2}{\text{day}}\right) = \frac{ED_{0-2}(2 \text{ yr}) \times SA_{0-2}\left(\frac{2,373 \text{ cm}^2}{\text{day}}\right) + ED_{2-6}(4 \text{ yr}) \times SA_{2-6}\left(\frac{2,373 \text{ cm}^2}{\text{day}}\right)}{ED_{0-2}(2 \text{ yr}) + ED_{2-6}(4 \text{ yr})}$$

$$IRS_{\text{res-c}}\left(\frac{200 \text{ mg}}{\text{day}}\right) = \frac{ED_{0-2}(2 \text{ yr}) \times IRS_{0-2}\left(\frac{200 \text{ mg}}{\text{day}}\right) + ED_{2-6}(4 \text{ yr}) \times IRS_{2-6}\left(\frac{200 \text{ mg}}{\text{day}}\right)}{ED_{0-2}(2 \text{ yr}) + ED_{2-6}(4 \text{ yr})}$$

- Adult

$$ED_{\text{res-a}}(20 \text{ yr}) = ED_{6-16}(10 \text{ yr}) + ED_{16-26}(10 \text{ yr})$$

$$BW_{\text{res-a}}(80 \text{ kg}) = \frac{ED_{6-16}(10 \text{ yr}) \times BW_{6-16}(80 \text{ kg}) + ED_{16-26}(10 \text{ yr}) \times BW_{16-26}(80 \text{ kg})}{ED_{6-16}(10 \text{ yr}) + ED_{16-26}(10 \text{ yr})}$$

$$EF_{\text{res-a}}\left(\frac{350 \text{ days}}{\text{yr}}\right) = \frac{ED_{6-16}(10 \text{ yr}) \times EF_{6-16}\left(\frac{350 \text{ days}}{\text{yr}}\right) + ED_{16-26}(10 \text{ yr}) \times EF_{16-26}\left(\frac{350 \text{ days}}{\text{yr}}\right)}{ED_{6-16}(10 \text{ yr}) + ED_{16-26}(10 \text{ yr})}$$

$$ET_{\text{res-a}}\left(\frac{24 \text{ hrs}}{\text{day}}\right) = \frac{ED_{6-16}(10 \text{ yr}) \times ET_{6-16}\left(\frac{24 \text{ hrs}}{\text{day}}\right) + ED_{16-26}(10 \text{ yr}) \times ET_{16-26}\left(\frac{24 \text{ hrs}}{\text{day}}\right)}{ED_{6-16}(10 \text{ yr}) + ED_{16-26}(10 \text{ yr})}$$

$$AF_{\text{res-a}}\left(\frac{0.07 \text{ mg}}{\text{cm}^2}\right) = \frac{ED_{6-16}(10 \text{ yr}) \times AF_{6-16}\left(\frac{0.07 \text{ mg}}{\text{cm}^2}\right) + ED_{16-26}(10 \text{ yr}) \times AF_{16-26}\left(\frac{0.07 \text{ mg}}{\text{cm}^2}\right)}{ED_{6-16}(10 \text{ yr}) + ED_{16-26}(10 \text{ yr})}$$

$$SA_{\text{res-a}}\left(\frac{6,032 \text{ cm}^2}{\text{day}}\right) = \frac{ED_{6-16}(10 \text{ yr}) \times SA_{6-16}\left(\frac{6,032 \text{ cm}^2}{\text{day}}\right) + ED_{16-26}(10 \text{ yr}) \times SA_{16-26}\left(\frac{6,032 \text{ cm}^2}{\text{day}}\right)}{ED_{6-16}(10 \text{ yr}) + ED_{16-26}(10 \text{ yr})}$$

$$IRS_{\text{res-a}}\left(\frac{100 \text{ mg}}{\text{day}}\right) = \frac{ED_{6-16}(10 \text{ yr}) \times IRS_{6-16}\left(\frac{100 \text{ mg}}{\text{day}}\right) + ED_{16-26}(10 \text{ yr}) \times IRS_{16-26}\left(\frac{100 \text{ mg}}{\text{day}}\right)}{ED_{6-16}(10 \text{ yr}) + ED_{16-26}(10 \text{ yr})}$$

- Age-adjusted

$$ED_{\text{res}}(26 \text{ yr}) = ED_{0-2}(2 \text{ yr}) + ED_{2-6}(4 \text{ yr}) + ED_{6-16}(10 \text{ yr}) + ED_{16-26}(10 \text{ yr})$$

$$EF_{\text{res}}\left(\frac{350 \text{ days}}{\text{yr}}\right) = \frac{\left(ED_{0-2}(2 \text{ yr}) \times EF_{0-2}\left(\frac{350 \text{ days}}{\text{yr}}\right) + ED_{2-6}(4 \text{ yr}) \times EF_{2-6}\left(\frac{350 \text{ days}}{\text{yr}}\right) + \right.}{ED_{0-2}(2 \text{ yr}) + ED_{2-6}(4 \text{ yr}) + ED_{6-16}(10 \text{ yr}) + ED_{16-26}(10 \text{ yr})} \left. \begin{matrix} ED_{6-16}(10 \text{ yr}) \times EF_{6-16}\left(\frac{350 \text{ days}}{\text{yr}}\right) + ED_{16-26}(10 \text{ yr}) \times EF_{16-26}\left(\frac{350 \text{ days}}{\text{yr}}\right) \end{matrix} \right)$$

$$ET_{\text{res}}\left(\frac{24 \text{ hrs}}{\text{day}}\right) = \frac{\left(ED_{0-2}(2 \text{ yr}) \times ET_{0-2}\left(\frac{24 \text{ hrs}}{\text{day}}\right) + ED_{2-6}(4 \text{ yr}) \times ET_{2-6}\left(\frac{24 \text{ hrs}}{\text{day}}\right) + \right.}{ED_{0-2}(2 \text{ yr}) + ED_{2-6}(4 \text{ yr}) + ED_{6-16}(10 \text{ yr}) + ED_{16-26}(10 \text{ yr})} \left. \begin{matrix} ED_{6-16}(10 \text{ yr}) \times ET_{6-16}\left(\frac{24 \text{ hrs}}{\text{day}}\right) + ED_{16-26}(10 \text{ yr}) \times ET_{16-26}\left(\frac{24 \text{ hrs}}{\text{day}}\right) \end{matrix} \right)$$

4.1.2 Resident Tapwater

This receptor is exposed to chemicals in water that are delivered into a residence from sources such as groundwater or surface water. Ingestion of drinking water is an appropriate pathway for all chemicals. The inhalation exposure route is only calculated for volatile compounds. Activities such as showering, laundering, and dish washing contribute to contaminants in the air for inhalation. Dermal contact with tapwater is also considered for analytes determined to be within the effective predictive domain as described in Section 4.9.8.

This land use is for developing residential default screening levels that are presented in the RSL Generic Tables.

4.1.2.1 Noncarcinogenic-child

The tapwater land use equation, presented here, contains the following exposure routes:

- ingestion of water

$$SL_{\text{res-wat-ingnc}}\left(\frac{\mu\text{g}}{\text{L}}\right) = \frac{\text{THQ} \times AT_{\text{res-c}}\left(\frac{365 \text{ days}}{\text{yr}}\right) \times ED_{\text{res-c}}(6 \text{ yr}) \times BW_{\text{res-c}}(15 \text{ kg})}{\left(\frac{1}{\text{RfDo}}\left(\frac{\text{mg}}{\text{kg-day}}\right)\right) \times \left(\frac{\text{mg}}{1000 \mu\text{g}}\right) \times EF_{\text{res-c}}\left(\frac{350 \text{ days}}{\text{yr}}\right) \times ED_{\text{res-c}}(6 \text{ yr}) \times IRW_{\text{res-c}}\left(\frac{0.78 \text{ L}}{\text{day}}\right)}$$

- dermal

For Inorganics:

$$SL_{\text{res-wat-dernc}} \left(\frac{\mu\text{g}}{\text{L}} \right) = \frac{DA_{\text{event}} \left(\frac{\mu\text{g}}{\text{cm}^2 \cdot \text{event}} \right) \times \left(\frac{1000 \text{ cm}^3}{\text{L}} \right)}{K_p \left(\frac{\text{cm}}{\text{hr}} \right) \times ET_{\text{event-res-c}} \left(\frac{0.54 \text{ hrs}}{\text{event}} \right)}$$

For Organics:

IF $ET_{\text{event-res-c}} \left(\frac{0.54 \text{ hrs}}{\text{event}} \right) \leq t^*$ (hrs), then:

$$SL_{\text{res-wat-dernc}} \left(\frac{\mu\text{g}}{\text{L}} \right) = \frac{DA_{\text{event}} \left(\frac{\mu\text{g}}{\text{cm}^2 \cdot \text{event}} \right) \times \left(\frac{1000 \text{ cm}^3}{\text{L}} \right)}{2 \times FA \times K_p \left(\frac{\text{cm}}{\text{hr}} \right) \times \sqrt{\frac{6 \times \tau_{\text{event}} \left(\frac{\text{hrs}}{\text{event}} \right) \times ET_{\text{event-res-c}} \left(\frac{0.54 \text{ hrs}}{\text{event}} \right)}{\pi}}}$$

or:

IF $ET_{\text{event-res-c}} \left(\frac{0.54 \text{ hrs}}{\text{event}} \right) > t^*$ (hrs), then:

$$SL_{\text{res-wat-dernc}} \left(\frac{\mu\text{g}}{\text{L}} \right) = \frac{DA_{\text{event}} \left(\frac{\mu\text{g}}{\text{cm}^2 \cdot \text{event}} \right) \times \left(\frac{1000 \text{ cm}^3}{\text{L}} \right)}{FA \times K_p \left(\frac{\text{cm}}{\text{hr}} \right) \times \left[\frac{ET_{\text{event-res-c}} \left(\frac{0.54 \text{ hrs}}{\text{event}} \right)}{1 + B} + 2 \times \tau_{\text{event}} \left(\frac{\text{hrs}}{\text{event}} \right) \times \left(\frac{1 + 3B + 3B^2}{(1 + B)^2} \right) \right]}$$

where:

$$DA_{\text{event}} \left(\frac{\mu\text{g}}{\text{cm}^2 \cdot \text{event}} \right) = \frac{THQ \times AT_{\text{res-c}} \left(\frac{365 \text{ days}}{\text{yr}} \times ED_{\text{res-c}} (6 \text{ yr}) \right) \times BW_{\text{res-c}} (15 \text{ kg})}{\left(\frac{1}{RfD_o \left(\frac{\text{mg}}{\text{kg} \cdot \text{day}} \right) \times GIABS} \right) \times \left(\frac{\text{mg}}{1000 \mu\text{g}} \right) \times EF_{\text{res-c}} \left(\frac{350 \text{ days}}{\text{yr}} \right) \times ED_{\text{res-c}} (6 \text{ yr}) \times EV_{\text{res-c}} \left(\frac{1 \text{ event}}{\text{day}} \right) \times SA_{\text{res-c}} (6,365 \text{ cm}^2)}$$

- inhalation of volatiles

$$SL_{\text{res-wat-inhnc}} \left(\frac{\mu\text{g}}{\text{L}} \right) = \frac{THQ \times AT_{\text{res-c}} \left(\frac{365 \text{ days}}{\text{yr}} \times ED_{\text{res-c}} (6 \text{ yr}) \right)}{\left(\frac{1}{RfC \left(\frac{\text{mg}}{\text{m}^3} \right)} \right) \times \left(\frac{\text{mg}}{1000 \mu\text{g}} \right) \times EF_{\text{res-c}} \left(\frac{350 \text{ days}}{\text{yr}} \right) \times ED_{\text{res-c}} (6 \text{ yr}) \times ET_{\text{res-c}} \left(\frac{24 \text{ hrs}}{\text{day}} \right) \times \left(\frac{1 \text{ day}}{24 \text{ hrs}} \right) \times K \left(\frac{0.5 \text{ L}}{\text{m}^3} \right)}$$

- Total

$$SL_{\text{res-wat-totnc}} \left(\frac{\mu\text{g}}{\text{L}} \right) = \frac{1}{\frac{1}{SL_{\text{res-wat-ingnc}}} + \frac{1}{SL_{\text{res-wat-inhnc}}} + \frac{1}{SL_{\text{res-wat-dernc}}}}$$

4.1.2.2 Noncarcinogenic-adult

The tapwater land use equation, presented here, contains the following exposure routes:

- ingestion of water

$$SL_{\text{res-wat-ingna}} \left(\frac{\mu\text{g}}{\text{L}} \right) = \frac{\text{THQ} \times \text{AT}_{\text{res-a}} \left(\frac{365 \text{ days}}{\text{yr}} \times \text{ED}_{\text{res}} (26 \text{ yr}) \right) \times \text{BW}_{\text{res-a}} (80 \text{ kg})}{\left(\frac{1}{\text{RfD}_o \left(\frac{\text{mg}}{\text{kg-day}} \right)} \right) \times \left(\frac{\text{mg}}{1000 \mu\text{g}} \right) \times \text{EF}_{\text{res-a}} \left(\frac{350 \text{ days}}{\text{yr}} \right) \times \text{ED}_{\text{res}} (26 \text{ yr}) \times \text{IRW}_{\text{res-a}} \left(\frac{2.5 \text{ L}}{\text{day}} \right)}$$

- dermal

For Inorganics:

$$SL_{\text{res-wat-derna}} \left(\frac{\mu\text{g}}{\text{L}} \right) = \frac{\text{DA}_{\text{event}} \left(\frac{\mu\text{g}}{\text{cm}^2\text{-event}} \right) \times \left(\frac{1000 \text{ cm}^3}{\text{L}} \right)}{K_p \left(\frac{\text{cm}}{\text{hr}} \right) \times \text{ET}_{\text{event-res-a}} \left(\frac{0.71 \text{ hrs}}{\text{event}} \right)}$$

For Organics:

IF $\text{ET}_{\text{event-res-a}} \left(\frac{0.71 \text{ hrs}}{\text{event}} \right) \leq t^*$ (hrs), then:

$$SL_{\text{res-wat-derna}} \left(\frac{\mu\text{g}}{\text{L}} \right) = \frac{\text{DA}_{\text{event}} \left(\frac{\mu\text{g}}{\text{cm}^2\text{-event}} \right) \times \left(\frac{1000 \text{ cm}^3}{\text{L}} \right)}{2 \times \text{FA} \times K_p \left(\frac{\text{cm}}{\text{hr}} \right) \times \sqrt{\frac{6 \times \tau_{\text{event}} \left(\frac{\text{hrs}}{\text{event}} \right) \times \text{ET}_{\text{event-res-a}} \left(\frac{0.71 \text{ hrs}}{\text{event}} \right)}{\pi}}}$$

or:

IF $\text{ET}_{\text{event-res-a}} \left(\frac{0.71 \text{ hrs}}{\text{event}} \right) > t^*$ (hrs), then:

$$SL_{\text{res-wat-derna}} \left(\frac{\mu\text{g}}{\text{L}} \right) = \frac{\text{DA}_{\text{event}} \left(\frac{\mu\text{g}}{\text{cm}^2\text{-event}} \right) \times \left(\frac{1000 \text{ cm}^3}{\text{L}} \right)}{\text{FA} \times K_p \left(\frac{\text{cm}}{\text{hr}} \right) \times \left[\frac{\text{ET}_{\text{event-res-a}} \left(\frac{0.71 \text{ hrs}}{\text{event}} \right)}{1 + B} + 2 \times \tau_{\text{event}} \left(\frac{\text{hrs}}{\text{event}} \right) \times \left(\frac{1 + 3B + 3B^2}{(1 + B)^2} \right) \right]}$$

where:

$$\text{DA}_{\text{event}} \left(\frac{\mu\text{g}}{\text{cm}^2\text{-event}} \right) = \frac{\text{THQ} \times \text{AT}_{\text{res-a}} \left(\frac{365 \text{ days}}{\text{yr}} \times \text{ED}_{\text{res}} (26 \text{ yr}) \right) \times \text{BW}_{\text{res-a}} (80 \text{ kg})}{\left(\frac{1}{\text{RfD}_o \left(\frac{\text{mg}}{\text{kg-day}} \right) \times \text{GIABS}} \right) \times \left(\frac{\text{mg}}{1000 \mu\text{g}} \right) \times \text{EF}_{\text{res-a}} \left(\frac{350 \text{ days}}{\text{yr}} \right) \times \text{ED}_{\text{res}} (26 \text{ yr}) \times \text{EV}_{\text{res-a}} \left(\frac{1 \text{ event}}{\text{day}} \right) \times \text{SA}_{\text{res-a}} (19,652 \text{ cm}^2)}$$

- inhalation of volatiles

$$SL_{\text{res-wat-inhna}} \left(\frac{\mu\text{g}}{\text{L}} \right) = \frac{\text{THQ} \times \text{AT}_{\text{res-a}} \left(\frac{365 \text{ days}}{\text{yr}} \times \text{ED}_{\text{res}} (26 \text{ yr}) \right)}{\left(\frac{1}{\text{RfC}} \left(\frac{\text{mg}}{\text{m}^3} \right) \right) \times \left(\frac{\text{mg}}{1000 \mu\text{g}} \right) \times \text{EF}_{\text{res-a}} \left(\frac{350 \text{ days}}{\text{yr}} \right) \times \text{ED}_{\text{res}} (26 \text{ yr}) \times \text{ET}_{\text{res-a}} \left(\frac{24 \text{ hrs}}{\text{day}} \right) \times \left(\frac{1 \text{ day}}{24 \text{ hrs}} \right) \times \text{K} \left(\frac{0.5 \text{ L}}{\text{m}^3} \right)}$$

- Total

$$SL_{\text{res-wat-totna}} \left(\frac{\mu\text{g}}{\text{L}} \right) = \frac{1}{\frac{1}{SL_{\text{res-wat-ingna}}} + \frac{1}{SL_{\text{res-wat-inhna}}} + \frac{1}{SL_{\text{res-wat-derna}}}}$$

4.1.2.3 Carcinogenic

The tapwater land use equation, presented here, contains the following exposure routes:

- ingestion of water

$$SL_{\text{res-wat-ingc}} \left(\frac{\mu\text{g}}{\text{L}} \right) = \frac{\text{TR} \times \text{AT}_{\text{res}} \left(\frac{365 \text{ days}}{\text{yr}} \times \text{LT} (70 \text{ yrs}) \right)}{\text{CSF}_o \left(\frac{\text{mg}}{\text{kg} \cdot \text{day}} \right)^{-1} \times \left(\frac{\text{mg}}{1000 \mu\text{g}} \right) \times \text{IFW}_{\text{res-adj}} \left(\frac{327.95 \text{ L}}{\text{kg}} \right)}$$

where:

$$\text{IFW}_{\text{res-adj}} \left(\frac{327.95 \text{ L}}{\text{kg}} \right) = \left[\frac{\text{EF}_{\text{res-c}} \left(\frac{350 \text{ days}}{\text{yr}} \right) \times \text{ED}_{\text{res-c}} (6 \text{ yr}) \times \text{IRW}_{\text{res-c}} \left(\frac{0.78 \text{ L}}{\text{day}} \right)}{\text{BW}_{\text{res-c}} (15 \text{ kg})} + \frac{\text{EF}_{\text{res-a}} \left(\frac{350 \text{ days}}{\text{yr}} \right) \times \text{ED}_{\text{res-a}} (20 \text{ yr}) \times \text{IRW}_{\text{res-a}} \left(\frac{2.5 \text{ L}}{\text{day}} \right)}{\text{BW}_{\text{res-a}} (80 \text{ kg})} \right]$$

- dermal

For Inorganics:

$$SL_{\text{res-wat-derc}} \left(\frac{\mu\text{g}}{\text{L}} \right) = \frac{DA_{\text{event}} \left(\frac{\mu\text{g}}{\text{cm}^2 \text{- event}} \right) \times \left(\frac{1000 \text{ cm}^3}{\text{L}} \right)}{K_p \left(\frac{\text{cm}}{\text{hr}} \right) \times ET_{\text{event-res-adj}} \left(\frac{0.671 \text{ hrs}}{\text{event}} \right)}$$

For Organics:

IF $ET_{\text{event-res-adj}} \left(\frac{0.671 \text{ hrs}}{\text{event}} \right) \leq t^*$ (hrs), then:

$$SL_{\text{res-wat-derc}} \left(\frac{\mu\text{g}}{\text{L}} \right) = \frac{DA_{\text{event}} \left(\frac{\mu\text{g}}{\text{cm}^2 \text{- event}} \right) \times \left(\frac{1000 \text{ cm}^3}{\text{L}} \right)}{2 \times FA \times K_p \left(\frac{\text{cm}}{\text{hr}} \right) \times \sqrt{\frac{6 \times t_{\text{event}} \left(\frac{\text{hrs}}{\text{event}} \right) \times ET_{\text{event-res-adj}} \left(\frac{0.671 \text{ hrs}}{\text{event}} \right)}{\pi}}}$$

or:

IF $ET_{\text{event-res-adj}} \left(\frac{0.671 \text{ hrs}}{\text{event}} \right) > t^*$ (hrs), then:

$$SL_{\text{res-wat-derc}} \left(\frac{\mu\text{g}}{\text{L}} \right) = \frac{DA_{\text{event}} \left(\frac{\mu\text{g}}{\text{cm}^2 \text{- event}} \right) \times \left(\frac{1000 \text{ cm}^3}{\text{L}} \right)}{FA \times K_p \left(\frac{\text{cm}}{\text{hr}} \right) \times \left[\frac{ET_{\text{event-res-adj}} \left(\frac{0.671 \text{ hrs}}{\text{event}} \right)}{1 + B} + 2 \times t_{\text{event}} \left(\frac{\text{hrs}}{\text{event}} \right) \times \left(\frac{1 + 3B + 3B^2}{(1 + B)^2} \right) \right]}$$

where:

$$ET_{\text{event-res-adj}} \left(\frac{0.671 \text{ hrs}}{\text{event}} \right) = \left(\frac{\left(ED_{\text{res-c}}(6 \text{ yr}) \times ET_{\text{event-res-c}} \left(\frac{0.54 \text{ hrs}}{\text{event}} \right) \right) + \left(ED_{\text{res-a}}(20 \text{ yr}) \times ET_{\text{event-res-a}} \left(\frac{0.71 \text{ hrs}}{\text{event}} \right) \right)}{ED_{\text{res}}(26 \text{ yr})} \right)$$

and:

$$DA_{\text{event}} \left(\frac{\mu\text{g}}{\text{cm}^2 \text{- event}} \right) = \frac{TR \times AT_{\text{res}} \left(\frac{365 \text{ days}}{\text{yr}} \times LT(70 \text{ yrs}) \right)}{\left(\frac{CSF_o \left(\frac{\text{mg}}{\text{kg} \text{- day}} \right)^{-1}}{GIABS} \right) \times \left(\frac{\text{mg}}{1000 \mu\text{g}} \right) \times DFW_{\text{res-adj}} \left(\frac{2,610,650 \text{ cm}^2 \text{- event}}{\text{kg}} \right)}$$

where:

$$DFW_{\text{res-adj}} \left(\frac{2,610,650 \text{ cm}^2 \text{- event}}{\text{kg}} \right) = \left(\frac{EF_{\text{res-c}} \left(\frac{350 \text{ days}}{\text{yr}} \right) \times ED_{\text{res-c}}(6 \text{ yr}) \times EV_{\text{res-c}} \left(\frac{1 \text{ event}}{\text{day}} \right) \times SA_{\text{res-c}}(6,365 \text{ cm}^2)}{BW_{\text{res-c}}(15 \text{ kg})} + \frac{EF_{\text{res-a}} \left(\frac{350 \text{ days}}{\text{yr}} \right) \times ED_{\text{res-a}}(20 \text{ yr}) \times EV_{\text{res-a}} \left(\frac{1 \text{ event}}{\text{day}} \right) \times SA_{\text{res-a}}(19,652 \text{ cm}^2)}{BW_{\text{res-a}}(80 \text{ kg})} \right)$$

- inhalation of volatiles

$$SL_{\text{res-wat-inhc}} \left(\frac{\mu\text{g}}{\text{L}} \right) = \frac{\text{TR} \times \text{AT}_{\text{res}} \left(\frac{365 \text{ days}}{\text{yr}} \times \text{LT}(70 \text{ yrs}) \right)}{\text{IUR} \left(\frac{\mu\text{g}}{\text{m}^3} \right)^{-1} \times \text{EF}_{\text{res}} \left(\frac{350 \text{ days}}{\text{yr}} \right) \times \text{ED}_{\text{res}}(26 \text{ yr}) \times \text{ET}_{\text{res}} \left(\frac{24 \text{ hrs}}{\text{day}} \right) \times \left(\frac{1 \text{ day}}{24 \text{ hrs}} \right) \times \text{K} \left(\frac{0.5 \text{ L}}{\text{m}^3} \right)}$$

- Total

$$SL_{\text{res-wat-totc}} \left(\frac{\mu\text{g}}{\text{L}} \right) = \frac{1}{\frac{1}{SL_{\text{res-wat-ingc}}} + \frac{1}{SL_{\text{res-wat-inhc}}} + \frac{1}{SL_{\text{res-wat-derc}}}}$$

4.1.2.4 Mutagenic

The tapwater land use equation, presented here, contains the following exposure routes:

- ingestion of water

$$SL_{\text{res-wat-ingmu}} \left(\frac{\mu\text{g}}{\text{L}} \right) = \frac{\text{TR} \times \text{AT}_{\text{res}} \left(\frac{365 \text{ days}}{\text{yr}} \times \text{LT}(70 \text{ yrs}) \right)}{\text{CSF}_o \left(\frac{\text{mg}}{\text{kg-day}} \right)^{-1} \times \left(\frac{\text{mg}}{1000 \mu\text{g}} \right) \times \text{IFWM}_{\text{res-adj}} \left(\frac{1,019.9 \text{ L}}{\text{kg}} \right)}$$

where:

$$\text{IFWM}_{\text{res-adj}} \left(\frac{1,019.9 \text{ L}}{\text{kg}} \right) = \left[\begin{array}{l} \frac{\text{EF}_{0-2} \left(\frac{350 \text{ days}}{\text{yr}} \right) \times \text{ED}_{0-2}(2 \text{ yr}) \times \text{IRW}_{0-2} \left(\frac{0.78 \text{ L}}{\text{day}} \right) \times 10}{\text{BW}_{0-2}(15 \text{ kg})} + \\ \frac{\text{EF}_{2-6} \left(\frac{350 \text{ days}}{\text{yr}} \right) \times \text{ED}_{2-6}(4 \text{ yr}) \times \text{IRW}_{2-6} \left(\frac{0.78 \text{ L}}{\text{day}} \right) \times 3}{\text{BW}_{2-6}(15 \text{ kg})} + \\ \frac{\text{EF}_{6-16} \left(\frac{350 \text{ days}}{\text{yr}} \right) \times \text{ED}_{6-16}(10 \text{ yr}) \times \text{IRW}_{6-16} \left(\frac{2.5 \text{ L}}{\text{day}} \right) \times 3}{\text{BW}_{6-16}(80 \text{ kg})} + \\ \frac{\text{EF}_{16-26} \left(\frac{350 \text{ days}}{\text{yr}} \right) \times \text{ED}_{16-26}(10 \text{ yr}) \times \text{IRW}_{16-26} \left(\frac{2.5 \text{ L}}{\text{day}} \right) \times 1}{\text{BW}_{16-26}(80 \text{ kg})} \end{array} \right]$$

- dermal

For Inorganics:

$$SL_{\text{res-wat-dermu}} \left(\frac{\mu\text{g}}{\text{L}} \right) = \frac{DA_{\text{event}} \left(\frac{\mu\text{g}}{\text{cm}^2 \cdot \text{event}} \right) \times \left(\frac{1000 \text{ cm}^3}{\text{L}} \right)}{K_p \left(\frac{\text{cm}}{\text{hr}} \right) \times ET_{\text{event-res-madj}} \left(\frac{0.671 \text{ hrs}}{\text{event}} \right)}$$

For Organics:

IF $ET_{\text{event-res-madj}} \left(\frac{0.671 \text{ hrs}}{\text{event}} \right) \leq t^*$ (hrs), then:

$$SL_{\text{res-wat-dermu}} \left(\frac{\mu\text{g}}{\text{L}} \right) = \frac{DA_{\text{event}} \left(\frac{\mu\text{g}}{\text{cm}^2 \cdot \text{event}} \right) \times \left(\frac{1000 \text{ cm}^3}{\text{L}} \right)}{2 \times FA \times K_p \left(\frac{\text{cm}}{\text{hr}} \right) \times \sqrt{\frac{6 \times \tau_{\text{event}} \left(\frac{\text{hrs}}{\text{event}} \right) \times ET_{\text{event-res-madj}} \left(\frac{0.671 \text{ hrs}}{\text{event}} \right)}{\pi}}}$$

or:

IF $ET_{\text{event-res-madj}} \left(\frac{0.671 \text{ hrs}}{\text{event}} \right) > t^*$ (hrs), then:

$$SL_{\text{res-wat-dermu}} \left(\frac{\mu\text{g}}{\text{L}} \right) = \frac{DA_{\text{event}} \left(\frac{\mu\text{g}}{\text{cm}^2 \cdot \text{event}} \right) \times \left(\frac{1000 \text{ cm}^3}{\text{L}} \right)}{FA \times K_p \left(\frac{\text{cm}}{\text{hr}} \right) \times \left[\frac{ET_{\text{event-res-madj}} \left(\frac{0.671 \text{ hrs}}{\text{event}} \right)}{1 + B} + 2 \times \tau_{\text{event}} \left(\frac{\text{hrs}}{\text{event}} \right) \times \left(\frac{1 + 3B + 3B^2}{(1 + B)^2} \right) \right]}$$

where:

$$ET_{\text{event-res-madj}} \left(\frac{0.671 \text{ hrs}}{\text{event}} \right) = \frac{\left(\left(ED_{0-2} (2 \text{ yr}) \times ET_{\text{event-(0-2)}} \left(\frac{0.54 \text{ hrs}}{\text{event}} \right) \right) + \left(ED_{2-6} (4 \text{ yr}) \times ET_{\text{event-(2-6)}} \left(\frac{0.54 \text{ hrs}}{\text{event}} \right) \right) + \left(ED_{6-16} (10 \text{ yr}) \times ET_{\text{event-(6-16)}} \left(\frac{0.71 \text{ hrs}}{\text{event}} \right) \right) + \left(ED_{16-26} (10 \text{ yr}) \times ET_{\text{event-(16-26)}} \left(\frac{0.71 \text{ hrs}}{\text{event}} \right) \right) \right)}{ED_{0-2} (2 \text{ yr}) + ED_{2-6} (4 \text{ yr}) + ED_{6-16} (10 \text{ yr}) + ED_{16-26} (10 \text{ yr})}$$

and:

$$DA_{\text{event}} \left(\frac{\mu\text{g}}{\text{cm}^2 \cdot \text{event}} \right) = \frac{TR \times AT_{\text{res}} \left(\frac{365 \text{ days}}{\text{yr}} \times LT (70 \text{ yrs}) \right)}{\left(\frac{CSF_o \left(\frac{\text{mg}}{\text{kg} \cdot \text{day}} \right)^{-1}}{GIABS} \right) \times \left(\frac{\text{mg}}{1000 \mu\text{g}} \right) \times DFWM_{\text{res-adj}} \left(\frac{8,191,633 \text{ cm}^2 \cdot \text{event}}{\text{kg}} \right)}$$

where:

$$DFWM_{\text{res-adj}} \left(\frac{8,191,633 \text{ cm}^2 \cdot \text{event}}{\text{kg}} \right) = \left(\frac{EF_{0-2} \left(\frac{350 \text{ days}}{\text{yr}} \right) \times ED_{0-2} (2 \text{ yr}) \times EV_{0-2} \left(\frac{1 \text{ event}}{\text{day}} \right) \times SA_{0-2} (6,365 \text{ cm}^2) \times 10}{BW_{0-2} (15 \text{ kg})} + \frac{EF_{2-6} \left(\frac{350 \text{ days}}{\text{yr}} \right) \times ED_{2-6} (4 \text{ yr}) \times EV_{2-6} \left(\frac{1 \text{ event}}{\text{day}} \right) \times SA_{2-6} (6,365 \text{ cm}^2) \times 3}{BW_{2-6} (15 \text{ kg})} + \frac{EF_{6-16} \left(\frac{350 \text{ days}}{\text{yr}} \right) \times ED_{6-16} (10 \text{ yr}) \times EV_{6-16} \left(\frac{1 \text{ event}}{\text{day}} \right) \times SA_{6-16} (19,652 \text{ cm}^2) \times 3}{BW_{6-16} (80 \text{ kg})} + \frac{EF_{16-26} \left(\frac{350 \text{ days}}{\text{yr}} \right) \times ED_{16-26} (10 \text{ yr}) \times EV_{16-26} \left(\frac{1 \text{ event}}{\text{day}} \right) \times SA_{16-26} (19,652 \text{ cm}^2) \times 1}{BW_{16-26} (80 \text{ kg})} \right)$$

- inhalation of volatiles

$$SL_{\text{res-wat-inhmu}} \left(\frac{\mu\text{g}}{\text{L}} \right) = \frac{TR \times AT_{\text{res}} \left(\frac{365 \text{ days}}{\text{yr}} \times LT(70 \text{ yrs}) \right)}{IUR \left(\frac{\mu\text{g}}{\text{m}^3} \right)^{-1} \times K \left(\frac{0.5 \text{ L}}{\text{m}^3} \right) \times \left[\begin{aligned} & \left(EF_{0-2} \left(\frac{350 \text{ days}}{\text{yr}} \right) \times ED_{0-2}(2 \text{ yr}) \times ET_{0-2} \left(\frac{24 \text{ hrs}}{\text{day}} \right) \times \left(\frac{1 \text{ day}}{24 \text{ hrs}} \right) \times 10 \right) + \\ & \left(EF_{2-6} \left(\frac{350 \text{ days}}{\text{yr}} \right) \times ED_{2-6}(4 \text{ yr}) \times ET_{2-6} \left(\frac{24 \text{ hrs}}{\text{day}} \right) \times \left(\frac{1 \text{ day}}{24 \text{ hrs}} \right) \times 3 \right) + \\ & \left(EF_{6-16} \left(\frac{350 \text{ days}}{\text{yr}} \right) \times ED_{6-16}(10 \text{ yr}) \times ET_{6-16} \left(\frac{24 \text{ hrs}}{\text{day}} \right) \times \left(\frac{1 \text{ day}}{24 \text{ hrs}} \right) \times 3 \right) + \\ & \left(EF_{16-26} \left(\frac{350 \text{ days}}{\text{yr}} \right) \times ED_{16-26}(10 \text{ yr}) \times ET_{16-26} \left(\frac{24 \text{ hrs}}{\text{day}} \right) \times \left(\frac{1 \text{ day}}{24 \text{ hrs}} \right) \times 1 \right) \end{aligned} \right]}$$

- Total

$$SL_{\text{res-wat-totmu}} \left(\frac{\mu\text{g}}{\text{L}} \right) = \frac{1}{\frac{1}{SL_{\text{res-wat-ingmu}}} + \frac{1}{SL_{\text{res-wat-inhmu}}} + \frac{1}{SL_{\text{res-wat-dermu}}}}$$

4.1.2.5 Vinyl Chloride - Carcinogenic

The tapwater land use equation, presented here, contains the following exposure routes:

- ingestion of water

$$SL_{\text{res-wat-ingvc}} \left(\frac{\mu\text{g}}{\text{L}} \right) = \frac{\text{TR}}{\left(\left(\frac{\text{CSF}_o \left(\frac{\text{mg}}{\text{kg-day}} \right)^{-1} \times \left(\frac{\text{mg}}{1000 \mu\text{g}} \right) \times \text{IFW}_{\text{res-adj}} \left(\frac{327.95 \text{ L}}{\text{kg}} \right)}{\text{AT}_{\text{res}} \left(\frac{365 \text{ days}}{\text{yr}} \times \text{LT} (70 \text{ yrs}) \right)} \right) + \left(\frac{\text{CSF}_o \left(\frac{\text{mg}}{\text{kg-day}} \right)^{-1} \times \left(\frac{\text{mg}}{1000 \mu\text{g}} \right) \times \text{IRW}_{\text{res-c}} \left(\frac{0.78 \text{ L}}{\text{day}} \right)}{\text{BW}_{\text{res-c}} (15 \text{ kg})} \right) \right)}$$

where:

$$\text{IFW}_{\text{res-adj}} \left(\frac{327.95 \text{ L}}{\text{kg}} \right) = \left[\frac{\text{EF}_{\text{res-c}} \left(\frac{350 \text{ days}}{\text{yr}} \right) \times \text{ED}_{\text{res-c}} (6 \text{ yr}) \times \text{IRW}_{\text{res-c}} \left(\frac{0.78 \text{ L}}{\text{day}} \right)}{\text{BW}_{\text{res-c}} (15 \text{ kg})} + \frac{\text{EF}_{\text{res-a}} \left(\frac{350 \text{ days}}{\text{yr}} \right) \times \text{ED}_{\text{res-a}} (20 \text{ yr}) \times \text{IRW}_{\text{res-a}} \left(\frac{2.5 \text{ L}}{\text{day}} \right)}{\text{BW}_{\text{res-a}} (80 \text{ kg})} \right]$$

- dermal

IF $ET_{\text{event-res-adj}} \left(\frac{0.671 \text{ hrs}}{\text{event}} \right) \leq t^*$ (hrs), then:

$$SL_{\text{res-wat-dervc}} \left(\frac{\mu\text{g}}{\text{L}} \right) = \frac{DA_{\text{vc-event}} \left(\frac{\mu\text{g}}{\text{cm}^2\text{-event}} \right) \times \left(\frac{1000 \text{ cm}^3}{\text{L}} \right)}{2 \times FA \times K_p \left(\frac{\text{cm}}{\text{hr}} \right) \times \sqrt{\frac{6 \times \tau_{\text{event}} \left(\frac{\text{hrs}}{\text{event}} \right) \times ET_{\text{event-res-adj}} \left(\frac{0.671 \text{ hrs}}{\text{event}} \right)}{\pi}}}$$

or,

IF $ET_{\text{event-res-adj}} \left(\frac{0.671 \text{ hrs}}{\text{event}} \right) > t^*$ (hrs), then:

$$SL_{\text{res-wat-dervc}} \left(\frac{\mu\text{g}}{\text{L}} \right) = \frac{DA_{\text{vc-event}} \left(\frac{\mu\text{g}}{\text{cm}^2\text{-event}} \right) \times \left(\frac{1000 \text{ cm}^3}{\text{L}} \right)}{FA \times K_p \left(\frac{\text{cm}}{\text{hr}} \right) \times \left[\frac{ET_{\text{event-res-adj}} \left(\frac{0.671 \text{ hrs}}{\text{event}} \right)}{1 + B} + 2 \times \tau_{\text{event}} \left(\frac{\text{hrs}}{\text{event}} \right) \times \left(\frac{1 + 3B + 3B^2}{(1 + B)^2} \right) \right]}$$

where:

$$ET_{\text{event-res-adj}} \left(\frac{0.671 \text{ hrs}}{\text{event}} \right) = \left(\frac{ED_{\text{res-c}}(6 \text{ yr}) \times ET_{\text{event-res-c}} \left(\frac{0.54 \text{ hrs}}{\text{event}} \right) + \left(ED_{\text{res-a}}(20 \text{ yr}) \times ET_{\text{event-res-a}} \left(\frac{0.71 \text{ hrs}}{\text{event}} \right) \right)}{ED_{\text{res}}(26 \text{ yr})} \right)$$

and:

$$DA_{\text{vc-event}} \left(\frac{\mu\text{g}}{\text{cm}^2\text{-event}} \right) = \frac{TR}{\left(\frac{CSF_o \left(\frac{\text{mg}}{\text{kg}\text{-day}} \right)^{-1}}{GIABS} \right) \times \left(\frac{\text{mg}}{1000 \mu\text{g}} \right) \times \left[\frac{DFW_{\text{res-adj}} \left(\frac{2,610,650 \text{ cm}^2\text{-event}}{\text{kg}} \right)}{AT_{\text{res}} \left(\frac{365 \text{ days}}{\text{yr}} \right) \times LT(70 \text{ yrs})} + \left(\frac{EV_{\text{res-c}} \left(\frac{1 \text{ event}}{\text{day}} \right) \times SA_{\text{res-c}}(6,365 \text{ cm}^2)}{BW_{\text{res-c}}(15 \text{ kg})} \right) \right]}$$

where:

$$DFW_{\text{res-adj}} \left(\frac{2,610,650 \text{ cm}^2\text{-event}}{\text{kg}} \right) = \left(\frac{EF_{\text{res-c}} \left(\frac{350 \text{ days}}{\text{yr}} \right) \times ED_{\text{res-c}}(6 \text{ yr}) \times EV_{\text{res-c}} \left(\frac{1 \text{ event}}{\text{day}} \right) \times SA_{\text{res-c}}(6,365 \text{ cm}^2)}{BW_{\text{res-c}}(15 \text{ kg})} + \frac{EF_{\text{res-a}} \left(\frac{350 \text{ days}}{\text{yr}} \right) \times ED_{\text{res-a}}(20 \text{ yr}) \times EV_{\text{res-a}} \left(\frac{1 \text{ event}}{\text{day}} \right) \times SA_{\text{res-a}}(19,652 \text{ cm}^2)}{BW_{\text{res-a}}(80 \text{ kg})} \right)$$

- inhalation of volatiles

$$SL_{\text{res-wat-inhvc}} \left(\frac{\mu\text{g}}{\text{L}} \right) = \frac{TR}{\left(\frac{\left(\frac{IUR \left(\frac{\mu\text{g}}{\text{m}^3} \right)^{-1} \times EF_{\text{res}} \left(\frac{350 \text{ days}}{\text{yr}} \right) \times ED_{\text{res}}(26 \text{ yr}) \times ET_{\text{res}} \left(\frac{24 \text{ hrs}}{\text{day}} \right) \times \left(\frac{1 \text{ day}}{24 \text{ hrs}} \right) \times K \left(\frac{0.5 \text{ L}}{\text{m}^3} \right) \right)}{AT_{\text{res}} \left(\frac{365 \text{ days}}{\text{yr}} \right) \times LT(70 \text{ yrs})} + \left(\frac{IUR \left(\frac{\mu\text{g}}{\text{m}^3} \right)^{-1} \times K \left(\frac{0.5 \text{ L}}{\text{m}^3} \right)}{\right)} \right)}$$

- Total

$$SL_{\text{res-wat-totvc}} \left(\frac{\mu\text{g}}{\text{L}} \right) = \frac{1}{\frac{1}{SL_{\text{res-wat-ingvc}}} + \frac{1}{SL_{\text{res-wat-inhvc}}} + \frac{1}{SL_{\text{res-wat-dervc}}}}$$

4.1.2.6 Trichloroethylene - Carcinogenic and Mutagenic

The tapwater land use equation, presented here, contains the following exposure routes:

- ingestion of water

$$SL_{\text{res-wat-ingtce}} \left(\frac{\mu\text{g}}{\text{L}} \right) = \frac{\text{TR} \times \text{AT}_{\text{res}} \left(\frac{365 \text{ days}}{\text{yr}} \times \text{LT} (70 \text{ yrs}) \right)}{\text{CSF}_o \left(\frac{\text{mg}}{\text{kg-day}} \right)^{-1} \times \left(\frac{\text{mg}}{1000 \mu\text{g}} \right) \times \left(\left(\text{CAF}_o (0.804) \times \text{IFW}_{\text{res-adj}} \left(\frac{327.95 \text{ L}}{\text{kg}} \right) \right) + \left(\text{MAF}_o (0.202) \times \text{IFWM}_{\text{res-adj}} \left(\frac{1,019.9 \text{ L}}{\text{kg}} \right) \right) \right)}$$

where:

$$\text{IFW}_{\text{res-adj}} \left(\frac{327.95 \text{ L}}{\text{kg}} \right) = \left[\frac{\text{EF}_{\text{res-c}} \left(\frac{350 \text{ days}}{\text{yr}} \right) \times \text{ED}_{\text{res-c}} (6 \text{ yr}) \times \text{IRW}_{\text{res-c}} \left(\frac{0.78 \text{ L}}{\text{day}} \right)}{\text{BW}_{\text{res-c}} (15 \text{ kg})} + \frac{\text{EF}_{\text{res-a}} \left(\frac{350 \text{ days}}{\text{yr}} \right) \times \text{ED}_{\text{res-a}} (20 \text{ yr}) \times \text{IRW}_{\text{res-a}} \left(\frac{2.5 \text{ L}}{\text{day}} \right)}{\text{BW}_{\text{res-a}} (80 \text{ kg})} \right]$$

and:

$$\text{IFWM}_{\text{res-adj}} \left(\frac{1,019.9 \text{ L}}{\text{kg}} \right) = \left[\frac{\text{EF}_{0-2} \left(\frac{350 \text{ days}}{\text{yr}} \right) \times \text{ED}_{0-2} (2 \text{ yr}) \times \text{IRW}_{0-2} \left(\frac{0.78 \text{ L}}{\text{day}} \right) \times 10}{\text{BW}_{0-2} (15 \text{ kg})} + \frac{\text{EF}_{2-6} \left(\frac{350 \text{ days}}{\text{yr}} \right) \times \text{ED}_{2-6} (4 \text{ yr}) \times \text{IRW}_{2-6} \left(\frac{0.78 \text{ L}}{\text{day}} \right) \times 3}{\text{BW}_{2-6} (15 \text{ kg})} + \frac{\text{EF}_{6-16} \left(\frac{350 \text{ days}}{\text{yr}} \right) \times \text{ED}_{6-16} (10 \text{ yr}) \times \text{IRW}_{6-16} \left(\frac{2.5 \text{ L}}{\text{day}} \right) \times 3}{\text{BW}_{6-16} (80 \text{ kg})} + \frac{\text{EF}_{16-26} \left(\frac{350 \text{ days}}{\text{yr}} \right) \times \text{ED}_{16-26} (10 \text{ yr}) \times \text{IRW}_{16-26} \left(\frac{2.5 \text{ L}}{\text{day}} \right) \times 1}{\text{BW}_{16-26} (80 \text{ kg})} \right]$$

- dermal

IF $ET_{\text{event-res-madj}} \left(\frac{0.671 \text{ hrs}}{\text{event}} \right) \leq t^* \text{ (hrs)}$, then:

$$SL_{\text{res-wat-derm}} \left(\frac{\mu\text{g}}{\text{L}} \right) = \frac{DA_{\text{tce-event}} \left(\frac{\mu\text{g}}{\text{cm}^2\text{-event}} \right) \times \left(\frac{1000 \text{ cm}^3}{\text{L}} \right)}{2 \times FA \times K_p \left(\frac{\text{cm}}{\text{hr}} \right) \times \sqrt{\frac{6 \times \tau_{\text{event}} \left(\frac{\text{hrs}}{\text{event}} \right) \times ET_{\text{event-res-madj}} \left(\frac{0.671 \text{ hrs}}{\text{event}} \right)}{\pi}}}$$

or:

IF $ET_{\text{event-res-madj}} \left(\frac{0.671 \text{ hrs}}{\text{event}} \right) > t^* \text{ (hrs)}$, then:

$$SL_{\text{res-wat-derm}} \left(\frac{\mu\text{g}}{\text{L}} \right) = \frac{DA_{\text{tce-event}} \left(\frac{\mu\text{g}}{\text{cm}^2\text{-event}} \right) \times \left(\frac{1000 \text{ cm}^3}{\text{L}} \right)}{FA \times K_p \left(\frac{\text{cm}}{\text{hr}} \right) \times \left[\frac{ET_{\text{event-res-madj}} \left(\frac{0.671 \text{ hrs}}{\text{event}} \right)}{1 + B} + 2 \times \tau_{\text{event}} \left(\frac{\text{hrs}}{\text{event}} \right) \times \left(\frac{1 + 3B + 3B^2}{(1 + B)^2} \right) \right]}$$

where:

$$ET_{\text{event-res-madj}} \left(\frac{0.671 \text{ hrs}}{\text{event}} \right) = \frac{\left(\left(ED_{0-2} (2 \text{ yr}) \times ET_{\text{event-(0-2)}} \left(\frac{0.54 \text{ hrs}}{\text{event}} \right) \right) + \left(ED_{2-6} (4 \text{ yr}) \times ET_{\text{event-(2-6)}} \left(\frac{0.54 \text{ hrs}}{\text{event}} \right) \right) + \left(\left(ED_{6-16} (10 \text{ yr}) \times ET_{\text{event-(6-16)}} \left(\frac{0.71 \text{ hrs}}{\text{event}} \right) \right) + \left(ED_{16-26} (10 \text{ yr}) \times ET_{\text{event-(16-26)}} \left(\frac{0.71 \text{ hrs}}{\text{event}} \right) \right) \right)}{ED_{0-2} (2 \text{ yr}) + ED_{2-6} (4 \text{ yr}) + ED_{6-16} (10 \text{ yr}) + ED_{16-26} (10 \text{ yr})}$$

and:

$$DA_{\text{tce-event}} \left(\frac{\mu\text{g}}{\text{cm}^2\text{-event}} \right) = \frac{TR \times AT_{\text{res}} \left(\frac{365 \text{ days}}{\text{yr}} \times LT (70 \text{ yrs}) \right)}{\left(\frac{CSF_0 \left(\frac{\text{mg}}{\text{kg-day}} \right)^{-1}}{GIABS} \right) \times \left(\frac{\text{mg}}{1000 \mu\text{g}} \right) \times \left[\left(CAF_0 (0.804) \times DFW_{\text{res-adj}} \left(\frac{2,610,650 \text{ cm}^2\text{-event}}{\text{kg}} \right) \right) + \left(MAF_0 (0.202) \times DFWM_{\text{res-adj}} \left(\frac{8,191,633 \text{ cm}^2\text{-event}}{\text{kg}} \right) \right) \right]}$$

where:

$$DFW_{\text{res-adj}} \left(\frac{2,610,650 \text{ cm}^2\text{-event}}{\text{kg}} \right) = \frac{\left(\frac{EF_{\text{res-c}} \left(\frac{350 \text{ days}}{\text{yr}} \right) \times ED_{\text{res-c}} (6 \text{ yr}) \times EV_{\text{res-c}} \left(\frac{1 \text{ event}}{\text{day}} \right) \times SA_{\text{res-c}} (6,365 \text{ cm}^2) \right)}{BW_{\text{res-c}} (15 \text{ kg})} + \frac{\left(EF_{\text{res-a}} \left(\frac{350 \text{ days}}{\text{yr}} \right) \times ED_{\text{res-a}} (20 \text{ yr}) \times EV_{\text{res-a}} \left(\frac{1 \text{ event}}{\text{day}} \right) \times SA_{\text{res-a}} (19,652 \text{ cm}^2) \right)}{BW_{\text{res-a}} (80 \text{ kg})}$$

and:

$$DFWM_{\text{res-adj}} \left(\frac{8,191,633 \text{ cm}^2\text{-event}}{\text{kg}} \right) = \frac{\left(\frac{EF_{0-2} \left(\frac{350 \text{ days}}{\text{yr}} \right) \times ED_{0-2} (2 \text{ yr}) \times EV_{0-2} \left(\frac{1 \text{ event}}{\text{day}} \right) \times SA_{0-2} (6,365 \text{ cm}^2) \times 10}{BW_{0-2} (15 \text{ kg})} + \frac{EF_{2-6} \left(\frac{350 \text{ days}}{\text{yr}} \right) \times ED_{2-6} (4 \text{ yr}) \times EV_{2-6} \left(\frac{1 \text{ event}}{\text{day}} \right) \times SA_{2-6} (6,365 \text{ cm}^2) \times 3}{BW_{2-6} (15 \text{ kg})} + \frac{EF_{6-16} \left(\frac{350 \text{ days}}{\text{yr}} \right) \times ED_{6-16} (10 \text{ yr}) \times EV_{6-16} \left(\frac{1 \text{ event}}{\text{day}} \right) \times SA_{6-16} (19,652 \text{ cm}^2) \times 3}{BW_{6-16} (80 \text{ kg})} + \frac{EF_{16-26} \left(\frac{350 \text{ days}}{\text{yr}} \right) \times ED_{16-26} (10 \text{ yr}) \times EV_{16-26} \left(\frac{1 \text{ event}}{\text{day}} \right) \times SA_{16-26} (19,652 \text{ cm}^2) \times 1}{BW_{16-26} (80 \text{ kg})} \right)}$$

- inhalation of volatiles

$$SL_{\text{res-wat-inhtce}} \left(\frac{\mu\text{g}}{\text{L}} \right) = \frac{\text{TR} \times \text{AT}_{\text{res}} \left(\frac{365 \text{ days}}{\text{yr}} \times \text{LT}(70 \text{ yrs}) \right)}{\text{IUR} \left(\frac{\mu\text{g}}{\text{m}^3} \right)^{-1} \times \text{K} \left(\frac{0.5 \text{ L}}{\text{m}^3} \right) \times \left[\begin{aligned} & \left(\text{EF}_{\text{res}} \left(\frac{350 \text{ days}}{\text{yr}} \right) \times \text{ED}_{\text{res}}(26 \text{ yr}) \times \text{ET}_{\text{res}} \left(\frac{24 \text{ hrs}}{\text{day}} \right) \times \left(\frac{1 \text{ day}}{24 \text{ hrs}} \right) \times \text{CAF}_i(0.756) \right) + \\ & \left(\text{EF}_{0-2} \left(\frac{350 \text{ days}}{\text{yr}} \right) \times \text{ED}_{0-2}(2 \text{ yr}) \times \text{ET}_{0-2} \left(\frac{24 \text{ hrs}}{\text{day}} \right) \times \left(\frac{1 \text{ day}}{24 \text{ hrs}} \right) \times \text{MAF}_i(0.244) \times 10 \right) + \\ & \left(\text{EF}_{2-6} \left(\frac{350 \text{ days}}{\text{yr}} \right) \times \text{ED}_{2-6}(4 \text{ yr}) \times \text{ET}_{2-6} \left(\frac{24 \text{ hrs}}{\text{day}} \right) \times \left(\frac{1 \text{ day}}{24 \text{ hrs}} \right) \times \text{MAF}_i(0.244) \times 3 \right) + \\ & \left(\text{EF}_{6-16} \left(\frac{350 \text{ days}}{\text{yr}} \right) \times \text{ED}_{6-16}(10 \text{ yr}) \times \text{ET}_{6-16} \left(\frac{24 \text{ hrs}}{\text{day}} \right) \times \left(\frac{1 \text{ day}}{24 \text{ hrs}} \right) \times \text{MAF}_i(0.244) \times 3 \right) + \\ & \left(\text{EF}_{16-26} \left(\frac{350 \text{ days}}{\text{yr}} \right) \times \text{ED}_{16-26}(10 \text{ yr}) \times \text{ET}_{16-26} \left(\frac{24 \text{ hrs}}{\text{day}} \right) \times \left(\frac{1 \text{ day}}{24 \text{ hrs}} \right) \times \text{MAF}_i(0.244) \times 1 \right) \end{aligned} \right]}$$

- Total

$$SL_{\text{res-wat-tottce}} \left(\frac{\mu\text{g}}{\text{L}} \right) = \frac{1}{\frac{1}{SL_{\text{res-wat-ingtce}}} + \frac{1}{SL_{\text{res-wat-inhtce}}} + \frac{1}{SL_{\text{res-wat-dertce}}}}$$

4.1.2.7 Supporting Equations

- Child

$$ED_{\text{res-c}}(6 \text{ yr}) = ED_{0-2}(2 \text{ yr}) + ED_{2-6}(4 \text{ yr})$$

$$BW_{\text{res-c}}(15 \text{ kg}) = \frac{ED_{0-2}(2 \text{ yr}) \times BW_{0-2}(15 \text{ kg}) + ED_{2-6}(4 \text{ yr}) \times BW_{2-6}(15 \text{ kg})}{ED_{0-2}(2 \text{ yr}) + ED_{2-6}(4 \text{ yr})}$$

$$EF_{\text{res-c}}\left(\frac{350 \text{ days}}{\text{yr}}\right) = \frac{ED_{0-2}(2 \text{ yr}) \times EF_{0-2}\left(\frac{350 \text{ days}}{\text{yr}}\right) + ED_{2-6}(4 \text{ yr}) \times EF_{2-6}\left(\frac{350 \text{ days}}{\text{yr}}\right)}{ED_{0-2}(2 \text{ yr}) + ED_{2-6}(4 \text{ yr})}$$

$$ET_{\text{res-c}}\left(\frac{24 \text{ hrs}}{\text{day}}\right) = \frac{ED_{0-2}(2 \text{ yr}) \times ET_{0-2}\left(\frac{24 \text{ hrs}}{\text{day}}\right) + ED_{2-6}(4 \text{ yr}) \times ET_{2-6}\left(\frac{24 \text{ hrs}}{\text{day}}\right)}{ED_{0-2}(2 \text{ yr}) + ED_{2-6}(4 \text{ yr})}$$

$$ET_{\text{event-res-c}}\left(\frac{0.54 \text{ hrs}}{\text{event}}\right) = \frac{ED_{0-2}(2 \text{ yr}) \times ET_{\text{event-(0-2)}}\left(\frac{0.54 \text{ hrs}}{\text{event}}\right) + ED_{2-6}(4 \text{ yr}) \times ET_{\text{event-(2-6)}}\left(\frac{0.54 \text{ hrs}}{\text{event}}\right)}{ED_{0-2}(2 \text{ yr}) + ED_{2-6}(4 \text{ yr})}$$

$$EV_{\text{res-c}}\left(\frac{1 \text{ event}}{\text{day}}\right) = \frac{ED_{0-2}(2 \text{ yr}) \times EV_{0-2}\left(\frac{1 \text{ event}}{\text{day}}\right) + ED_{2-6}(4 \text{ yr}) \times EV_{2-6}\left(\frac{1 \text{ event}}{\text{day}}\right)}{ED_{0-2}(2 \text{ yr}) + ED_{2-6}(4 \text{ yr})}$$

$$SA_{\text{res-c}}(6,365 \text{ cm}^2) = \frac{ED_{0-2}(2 \text{ yr}) \times SA_{0-2}(6,365 \text{ cm}^2) + ED_{2-6}(4 \text{ yr}) \times SA_{2-6}(6,365 \text{ cm}^2)}{ED_{0-2}(2 \text{ yr}) + ED_{2-6}(4 \text{ yr})}$$

$$IRW_{\text{res-c}}\left(\frac{0.78 \text{ L}}{\text{day}}\right) = \frac{ED_{0-2}(2 \text{ yr}) \times IRW_{0-2}\left(\frac{0.78 \text{ L}}{\text{day}}\right) + ED_{2-6}(4 \text{ yr}) \times IRW_{2-6}\left(\frac{0.78 \text{ L}}{\text{day}}\right)}{ED_{0-2}(2 \text{ yr}) + ED_{2-6}(4 \text{ yr})}$$

- Adult

$$ED_{\text{res-a}}(20 \text{ yr}) = ED_{6-16}(10 \text{ yr}) + ED_{16-26}(10 \text{ yr})$$

$$BW_{\text{res-a}}(80 \text{ kg}) = \frac{ED_{6-16}(10 \text{ yr}) \times BW_{6-16}(80 \text{ kg}) + ED_{16-26}(10 \text{ yr}) \times BW_{16-26}(80 \text{ kg})}{ED_{6-16}(10 \text{ yr}) + ED_{16-26}(10 \text{ yr})}$$

$$EF_{\text{res-a}}\left(\frac{350 \text{ days}}{\text{yr}}\right) = \frac{ED_{6-16}(10 \text{ yr}) \times EF_{6-16}\left(\frac{350 \text{ days}}{\text{yr}}\right) + ED_{16-26}(10 \text{ yr}) \times EF_{16-26}\left(\frac{350 \text{ days}}{\text{yr}}\right)}{ED_{6-16}(10 \text{ yr}) + ED_{16-26}(10 \text{ yr})}$$

$$ET_{\text{res-a}}\left(\frac{24 \text{ hrs}}{\text{day}}\right) = \frac{ED_{6-16}(10 \text{ yr}) \times ET_{6-16}\left(\frac{24 \text{ hrs}}{\text{day}}\right) + ED_{16-26}(10 \text{ yr}) \times ET_{16-26}\left(\frac{24 \text{ hrs}}{\text{day}}\right)}{ED_{6-16}(10 \text{ yr}) + ED_{16-26}(10 \text{ yr})}$$

$$ET_{\text{event-res-a}}\left(\frac{0.71 \text{ hrs}}{\text{event}}\right) = \frac{ED_{6-16}(10 \text{ yr}) \times ET_{\text{event-(6-16)}}\left(\frac{0.71 \text{ hrs}}{\text{event}}\right) + ED_{16-26}(10 \text{ yr}) \times ET_{\text{event-(16-26)}}\left(\frac{0.71 \text{ hrs}}{\text{event}}\right)}{ED_{6-16}(10 \text{ yr}) + ED_{16-26}(10 \text{ yr})}$$

$$EV_{\text{res-a}}\left(\frac{1 \text{ event}}{\text{day}}\right) = \frac{ED_{6-16}(10 \text{ yr}) \times EV_{6-16}\left(\frac{1 \text{ event}}{\text{day}}\right) + ED_{16-26}(10 \text{ yr}) \times EV_{16-26}\left(\frac{1 \text{ event}}{\text{day}}\right)}{ED_{6-16}(10 \text{ yr}) + ED_{16-26}(10 \text{ yr})}$$

$$SA_{\text{res-a}}(19,652 \text{ cm}^2) = \frac{ED_{6-16}(10 \text{ yr}) \times SA_{6-16}(19,652 \text{ cm}^2) + ED_{16-26}(10 \text{ yr}) \times SA_{16-26}(19,652 \text{ cm}^2)}{ED_{6-16}(10 \text{ yr}) + ED_{16-26}(10 \text{ yr})}$$

$$IRW_{\text{res-a}}\left(\frac{2.5 \text{ L}}{\text{day}}\right) = \frac{ED_{6-16}(10 \text{ yr}) \times IRW_{6-16}\left(\frac{2.5 \text{ L}}{\text{day}}\right) + ED_{16-26}(10 \text{ yr}) \times IRW_{16-26}\left(\frac{2.5 \text{ L}}{\text{day}}\right)}{ED_{6-16}(10 \text{ yr}) + ED_{16-26}(10 \text{ yr})}$$

- Age-adjusted

$$ED_{\text{res}}(26 \text{ yr}) = ED_{0-2}(2 \text{ yr}) + ED_{2-6}(4 \text{ yr}) + ED_{6-16}(10 \text{ yr}) + ED_{16-26}(10 \text{ yr})$$

$$EF_{\text{res}}\left(\frac{350 \text{ days}}{\text{yr}}\right) = \frac{\left(ED_{0-2}(2 \text{ yr}) \times EF_{0-2}\left(\frac{350 \text{ days}}{\text{yr}}\right) + ED_{2-6}(4 \text{ yr}) \times EF_{2-6}\left(\frac{350 \text{ days}}{\text{yr}}\right) + ED_{6-16}(10 \text{ yr}) \times EF_{6-16}\left(\frac{350 \text{ days}}{\text{yr}}\right) + ED_{16-26}(10 \text{ yr}) \times EF_{16-26}\left(\frac{350 \text{ days}}{\text{yr}}\right) \right)}{ED_{0-2}(2 \text{ yr}) + ED_{2-6}(4 \text{ yr}) + ED_{6-16}(10 \text{ yr}) + ED_{16-26}(10 \text{ yr})}$$

$$ET_{\text{res}}\left(\frac{24 \text{ hrs}}{\text{day}}\right) = \frac{\left(ED_{0-2}(2 \text{ yr}) \times ET_{0-2}\left(\frac{24 \text{ hrs}}{\text{day}}\right) + ED_{2-6}(4 \text{ yr}) \times ET_{2-6}\left(\frac{24 \text{ hrs}}{\text{day}}\right) + ED_{6-16}(10 \text{ yr}) \times ET_{6-16}\left(\frac{24 \text{ hrs}}{\text{day}}\right) + ED_{16-26}(10 \text{ yr}) \times ET_{16-26}\left(\frac{24 \text{ hrs}}{\text{day}}\right) \right)}{ED_{0-2}(2 \text{ yr}) + ED_{2-6}(4 \text{ yr}) + ED_{6-16}(10 \text{ yr}) + ED_{16-26}(10 \text{ yr})}$$

4.1.3 Resident Air

This receptor spends most, if not all, of the day at home. The activities for this receptor involve typical home making chores (cooking, cleaning and laundering) as well as outdoor activities. The resident is assumed to be exposed to contaminants via the following pathway: inhalation of ambient air. This land use has no assumptions of how contaminants get into the air and the RSLs derived should be compared to air samples.

This land use is for developing residential default screening levels that are presented in the RSL Generic Tables.

4.1.3.1 Noncarcinogenic

The air land use equation, presented here, contains the following exposure routes:

- inhalation

$$SL_{\text{res-air-inhn}}\left(\frac{\mu\text{g}}{\text{m}^3}\right) = \frac{\text{THQ} \times \text{AT}_{\text{res-a}}\left(\frac{365 \text{ days}}{\text{yr}}\right) \times ED_{\text{res}}(26 \text{ yr})}{\left(\frac{1}{\text{RfC}}\left(\frac{\text{mg}}{\text{m}^3}\right)\right) \times \left(\frac{\text{mg}}{1000 \mu\text{g}}\right) \times EF_{\text{res}}\left(\frac{350 \text{ days}}{\text{yr}}\right) \times ED_{\text{res}}(26 \text{ yr}) \times ET_{\text{res}}\left(\frac{24 \text{ hrs}}{\text{day}}\right) \times \left(\frac{1 \text{ day}}{24 \text{ hrs}}\right)}$$

4.1.3.2 Carcinogenic

The air land use equation, presented here, contains the following exposure routes:

- inhalation

$$SL_{\text{res-air-inhc}} \left(\frac{\mu\text{g}}{\text{m}^3} \right) = \frac{TR \times AT_{\text{res}} \left(\frac{365 \text{ days}}{\text{yr}} \times LT(70 \text{ yrs}) \right)}{IUR \left(\frac{\mu\text{g}}{\text{m}^3} \right)^{-1} \times EF_{\text{res}} \left(\frac{350 \text{ days}}{\text{yr}} \right) \times ED_{\text{res}}(26 \text{ yr}) \times ET_{\text{res}} \left(\frac{24 \text{ hrs}}{\text{day}} \right) \times \left(\frac{1 \text{ day}}{24 \text{ hrs}} \right)}$$

4.1.3.3 Mutagenic

The air land use equation, presented here, contains the following exposure routes:

- inhalation

$$SL_{\text{res-air-inhmc}} \left(\frac{\mu\text{g}}{\text{m}^3} \right) = \frac{TR \times AT_{\text{res}} \left(\frac{365 \text{ days}}{\text{yr}} \times LT(70 \text{ yrs}) \right)}{IUR \left(\frac{\mu\text{g}}{\text{m}^3} \right)^{-1} \times \left[\begin{aligned} & \left(EF_{0-2} \left(\frac{350 \text{ days}}{\text{yr}} \right) \times ED_{0-2}(2 \text{ yr}) \times ET_{0-2} \left(\frac{24 \text{ hrs}}{\text{day}} \right) \times \left(\frac{1 \text{ day}}{24 \text{ hrs}} \right) \times 10 \right) + \\ & \left(EF_{2-6} \left(\frac{350 \text{ days}}{\text{yr}} \right) \times ED_{2-6}(4 \text{ yr}) \times ET_{2-6} \left(\frac{24 \text{ hrs}}{\text{day}} \right) \times \left(\frac{1 \text{ day}}{24 \text{ hrs}} \right) \times 3 \right) + \\ & \left(EF_{6-16} \left(\frac{350 \text{ days}}{\text{yr}} \right) \times ED_{6-16}(10 \text{ yr}) \times ET_{6-16} \left(\frac{24 \text{ hrs}}{\text{day}} \right) \times \left(\frac{1 \text{ day}}{24 \text{ hrs}} \right) \times 3 \right) + \\ & \left(EF_{16-26} \left(\frac{350 \text{ days}}{\text{yr}} \right) \times ED_{16-26}(10 \text{ yr}) \times ET_{16-26} \left(\frac{24 \text{ hrs}}{\text{day}} \right) \times \left(\frac{1 \text{ day}}{24 \text{ hrs}} \right) \times 1 \right) \end{aligned} \right]}$$

4.1.3.4 Vinyl Chloride - Carcinogenic

The air land use equation, presented here, contains the following exposure routes:

- inhalation

$$SL_{\text{res-air-inhvc}} \left(\frac{\mu\text{g}}{\text{m}^3} \right) = \frac{TR}{IUR \left(\frac{\mu\text{g}}{\text{m}^3} \right)^{-1} + \left(\frac{IUR \left(\frac{\mu\text{g}}{\text{m}^3} \right)^{-1} \times EF_{\text{res}} \left(\frac{350 \text{ days}}{\text{yr}} \right) \times ED_{\text{res}}(26 \text{ yr}) \times ET_{\text{res}} \left(\frac{24 \text{ hrs}}{\text{day}} \right) \times \left(\frac{1 \text{ day}}{24 \text{ hrs}} \right)}{AT_{\text{res}} \left(\frac{365 \text{ days}}{\text{yr}} \times LT(70 \text{ yrs}) \right)}$$

4.1.3.5 Trichloroethylene - Carcinogenic and Mutagenic

The air land use equation, presented here, contains the following exposure routes:

- inhalation

$$SL_{\text{res-air-inhtce}} \left(\frac{\mu\text{g}}{\text{m}^3} \right) = \frac{TR \times AT_{\text{res}} \left(\frac{365 \text{ days}}{\text{yr}} \times LT(70 \text{ yrs}) \right)}{\left[\begin{aligned} & \left(EF_{\text{res}} \left(\frac{350 \text{ days}}{\text{yr}} \right) \times ED_{\text{res}}(26 \text{ yr}) \times ET_{\text{res}} \left(\frac{24 \text{ hrs}}{\text{day}} \right) \times \left(\frac{1 \text{ day}}{24 \text{ hrs}} \right) \times CAF_i(0.756) \right) + \\ & \left(EF_{0-2} \left(\frac{350 \text{ days}}{\text{yr}} \right) \times ED_{0-2}(2 \text{ yr}) \times ET_{0-2} \left(\frac{24 \text{ hrs}}{\text{day}} \right) \times \left(\frac{1 \text{ day}}{24 \text{ hrs}} \right) \times MAF_i(0.244) \times 10 \right) + \\ & \left(EF_{2-6} \left(\frac{350 \text{ days}}{\text{yr}} \right) \times ED_{2-6}(4 \text{ yr}) \times ET_{2-6} \left(\frac{24 \text{ hrs}}{\text{day}} \right) \times \left(\frac{1 \text{ day}}{24 \text{ hrs}} \right) \times MAF_i(0.244) \times 3 \right) + \\ & \left(EF_{6-16} \left(\frac{350 \text{ days}}{\text{yr}} \right) \times ED_{6-16}(10 \text{ yr}) \times ET_{6-16} \left(\frac{24 \text{ hrs}}{\text{day}} \right) \times \left(\frac{1 \text{ day}}{24 \text{ hrs}} \right) \times MAF_i(0.244) \times 3 \right) + \\ & \left(EF_{16-26} \left(\frac{350 \text{ days}}{\text{yr}} \right) \times ED_{16-26}(10 \text{ yr}) \times ET_{16-26} \left(\frac{24 \text{ hrs}}{\text{day}} \right) \times \left(\frac{1 \text{ day}}{24 \text{ hrs}} \right) \times MAF_i(0.244) \times 1 \right) \end{aligned} \right]} IUR \left(\frac{\mu\text{g}}{\text{m}^3} \right)^{-1}$$

4.2 Composite Worker

4.2.1 Composite Worker Soil

This is a long-term receptor exposed during the work day who is a full-time employee working on-site and spends most of the workday conducting maintenance activities outdoors. The activities for this receptor (e.g., moderate digging, landscaping) typically involve on-site exposure to surface soils. The composite worker is expected to have an elevated soil ingestion rate (100 mg per day) and is assumed to be exposed to contaminants via the following pathways: incidental ingestion of soil, dermal contact with soil, inhalation of volatiles and fugitive dust. The composite worker combines the most protective exposure assumptions of the outdoor and indoor workers. The only difference between the outdoor worker and the composite worker is that the composite worker uses the more protective exposure frequency of 250 days/year from the indoor worker scenario.

This land use is for developing industrial default screening levels that are presented in the RSL Generic Tables.

4.2.1.1 Noncarcinogenic

The composite worker soil land use equation, presented here, contains the following exposure routes:

- incidental ingestion of soil

$$SL_{\text{com-sol-ingn}} \left(\frac{\text{mg}}{\text{kg}} \right) = \frac{\text{THQ} \times \text{AT}_{\text{com-a}} \left(\frac{365 \text{ days}}{\text{yr}} \times \text{ED}_{\text{com}} (25 \text{ yr}) \right) \times \text{BW}_{\text{com}} (80 \text{ kg})}{\left(\frac{\text{RBA}}{\text{RfD}_o \left(\frac{\text{mg}}{\text{kg-day}} \right)} \right) \times \left(\frac{10^{-6} \text{ kg}}{\text{mg}} \right) \times \text{EF}_{\text{com}} \left(\frac{250 \text{ days}}{\text{yr}} \right) \times \text{ED}_{\text{com}} (25 \text{ yr}) \times \text{IRS}_{\text{com}} \left(\frac{100 \text{ mg}}{\text{day}} \right)}$$

- dermal exposure

$$SL_{\text{com-sol-dern}} \left(\frac{\text{mg}}{\text{kg}} \right) = \frac{\text{THQ} \times \text{AT}_{\text{com-a}} \left(\frac{365 \text{ days}}{\text{yr}} \times \text{ED}_{\text{com}} (25 \text{ yr}) \right) \times \text{BW}_{\text{com}} (80 \text{ kg})}{\left(\frac{1}{\text{RfD}_o \left(\frac{\text{mg}}{\text{kg-day}} \right) \times \text{GIABS}} \right) \times \left(\frac{10^{-6} \text{ kg}}{\text{mg}} \right) \times \text{EF}_{\text{com}} \left(\frac{250 \text{ days}}{\text{yr}} \right) \times \text{ED}_{\text{com}} (25 \text{ yr}) \times \text{SA}_{\text{com}} \left(\frac{3,527 \text{ cm}^2}{\text{day}} \right) \times \text{AF}_{\text{com}} \left(\frac{0.12 \text{ mg}}{\text{cm}^2} \right) \times \text{ABS}_d}$$

- inhalation of volatiles and particulates emitted from soil

$$SL_{\text{com-sol-inhn}} \left(\frac{\text{mg}}{\text{kg}} \right) = \frac{\text{THQ} \times \text{AT}_{\text{com-a}} \left(\frac{365 \text{ days}}{\text{yr}} \times \text{ED}_{\text{com}} (25 \text{ yr}) \right)}{\left(\frac{1}{\text{RfC} \left(\frac{\text{mg}}{\text{m}^3} \right)} \right) \times \text{EF}_{\text{com}} \left(\frac{250 \text{ days}}{\text{yr}} \right) \times \text{ED}_{\text{com}} (25 \text{ yr}) \times \text{ET}_{\text{com}} \left(\frac{8 \text{ hrs}}{\text{day}} \right) \times \left(\frac{1 \text{ day}}{24 \text{ hrs}} \right) \times \left(\frac{1}{\text{VF}_{\text{ulim}} \left(\frac{\text{m}^3}{\text{kg}} \right)} + \frac{1}{\text{PEF} \left(\frac{\text{m}^3}{\text{kg}} \right)} \right)}$$

- Total

$$SL_{\text{com-sol-totn}} \left(\frac{\text{mg}}{\text{kg}} \right) = \frac{1}{\frac{1}{\text{PRG}_{\text{com-sol-ingn}}} + \frac{1}{\text{PRG}_{\text{com-sol-inhn}}} + \frac{1}{\text{PRG}_{\text{com-sol-dern}}}}$$

4.2.1.2 Carcinogenic

The composite worker soil land use equation, presented here, contains the following exposure routes:

- incidental ingestion of soil

$$SL_{\text{com-sol-ingc}} \left(\frac{\text{mg}}{\text{kg}} \right) = \frac{TR \times AT_{\text{com}} \left(\frac{365 \text{ days}}{\text{yr}} \times LT(70 \text{ yrs}) \right) \times BW_{\text{com}} (80 \text{ kg})}{CSF_o \left(\frac{\text{mg}}{\text{kg-day}} \right)^{-1} \times \left(\frac{10^{-6} \text{ kg}}{\text{mg}} \right) \times RBA \times EF_{\text{com}} \left(\frac{250 \text{ days}}{\text{yr}} \right) \times ED_{\text{com}} (25 \text{ yr}) \times IRS_{\text{com}} \left(\frac{100 \text{ mg}}{\text{day}} \right)}$$

- dermal exposure

$$SL_{\text{com-sol-derc}} \left(\frac{\text{mg}}{\text{kg}} \right) = \frac{TR \times AT_{\text{com}} \left(\frac{365 \text{ days}}{\text{yr}} \times LT(70 \text{ yrs}) \right) \times BW_{\text{com}} (80 \text{ kg})}{\left(\frac{CSF_o \left(\frac{\text{mg}}{\text{kg-day}} \right)^{-1}}{GIABS} \right) \times \left(\frac{10^{-6} \text{ kg}}{\text{mg}} \right) \times EF_{\text{com}} \left(\frac{250 \text{ days}}{\text{yr}} \right) \times ED_{\text{com}} (25 \text{ yr}) \times SA_{\text{com}} \left(\frac{3,527 \text{ cm}^2}{\text{day}} \right) \times AF_{\text{com}} \left(\frac{0.12 \text{ mg}}{\text{cm}^2} \right) \times ABS_d}$$

- inhalation of volatiles and particulates emitted from soil

$$SL_{\text{com-sol-inhc}} \left(\frac{\text{mg}}{\text{kg}} \right) = \frac{TR \times AT_{\text{com}} \left(\frac{365 \text{ days}}{\text{yr}} \times LT(70 \text{ yrs}) \right)}{IUR \left(\frac{\mu\text{g}}{\text{m}^3} \right)^{-1} \times \left(\frac{1000 \mu\text{g}}{\text{mg}} \right) \times EF_{\text{com}} \left(\frac{250 \text{ days}}{\text{yr}} \right) \times ED_{\text{com}} (25 \text{ yr}) \times ET_{\text{com}} \left(\frac{8 \text{ hrs}}{\text{day}} \right) \times \left(\frac{1 \text{ day}}{24 \text{ hrs}} \right) \times \left(\frac{1}{VF_{\text{ulim}} \left(\frac{\text{m}^3}{\text{kg}} \right)} + \frac{1}{PEF \left(\frac{\text{m}^3}{\text{kg}} \right)} \right)}$$

- Total

$$SL_{\text{com-sol-totc}} \left(\frac{\text{mg}}{\text{kg}} \right) = \frac{1}{\frac{1}{PRG_{\text{com-sol-ingc}}} + \frac{1}{PRG_{\text{com-sol-inhc}}} + \frac{1}{PRG_{\text{com-sol-derc}}}}$$

4.2.2 Composite Worker Air

This is a long-term receptor exposed during the work day who is a full-time employee working on-site and spends most of the workday conducting maintenance activities indoors. The composite worker is assumed to be exposed to contaminants via the following pathway: inhalation of ambient air. The composite worker combines the most protective exposure assumptions of the outdoor and indoor workers. The only difference between the outdoor worker and the composite worker is that the composite worker uses the more protective

exposure frequency of 250 days/year from the indoor worker scenario. This land use has no assumptions of how contaminants get into the air and the RSLs derived should be compared to air samples.

This land use is for developing industrial default screening levels that are presented in the RSL Generic Tables.

4.2.2.1 Noncarcinogenic

The air land use equation, presented here, contains the following exposure routes:

- Inhalation

$$SL_{\text{com-air-inhn}} \left(\frac{\mu\text{g}}{\text{m}^3} \right) = \frac{\text{THQ} \times \text{AT}_{\text{com-a}} \left(\frac{365 \text{ days}}{\text{yr}} \times \text{ED}_{\text{com}} (25 \text{ yr}) \right)}{\left(\frac{1}{\text{RfC}} \left(\frac{\text{mg}}{\text{m}^3} \right) \right) \times \left(\frac{\text{mg}}{1000 \mu\text{g}} \right) \times \text{EF}_{\text{com}} \left(\frac{250 \text{ days}}{\text{yr}} \right) \times \text{ED}_{\text{com}} (25 \text{ yr}) \times \text{ET}_{\text{com}} \left(\frac{8 \text{ hrs}}{\text{day}} \right) \times \left(\frac{1 \text{ day}}{24 \text{ hrs}} \right)}$$

4.2.2.2 Carcinogenic

The air land use equation, presented here, contains the following exposure routes:

- Inhalation

$$SL_{\text{com-air-inhc}} \left(\frac{\mu\text{g}}{\text{m}^3} \right) = \frac{\text{TR} \times \text{AT}_{\text{com}} \left(\frac{365 \text{ days}}{\text{yr}} \times \text{LT} (70 \text{ yrs}) \right)}{\text{IUR} \left(\frac{\mu\text{g}}{\text{m}^3} \right)^{-1} \times \text{EF}_{\text{com}} \left(\frac{250 \text{ days}}{\text{yr}} \right) \times \text{ED}_{\text{com}} (25 \text{ yr}) \times \text{ET}_{\text{com}} \left(\frac{8 \text{ hrs}}{\text{day}} \right) \times \left(\frac{1 \text{ day}}{24 \text{ hrs}} \right)}$$

4.3 Outdoor Worker

4.3.1 Outdoor Worker Soil

This is a long-term receptor exposed during the work day who is a full-time employee working on-site and spends most of the workday conducting maintenance activities outdoors. The activities for this receptor (e.g., moderate digging, landscaping) typically involve on-site exposure to surface soils. The outdoor worker is expected to have an elevated soil ingestion rate (100 mg

per day) and is assumed to be exposed to contaminants via the following pathways: incidental ingestion of soil, dermal contact with soil, inhalation of volatiles and fugitive dust. The outdoor worker receives more exposure than the indoor worker under commercial/industrial conditions.

The outdoor worker soil land use is not provided in the RSL Generic Tables but RSLs can be created by using the Calculator.

4.3.1.1 Noncarcinogenic

The outdoor worker soil land use equation, presented here, contains the following exposure routes:

- incidental ingestion of soil

$$SL_{\text{out-sol-ingn}} \left(\frac{\text{mg}}{\text{kg}} \right) = \frac{\text{THQ} \times AT_{\text{out-a}} \left(\frac{365 \text{ days}}{\text{yr}} \times ED_{\text{out}}(25 \text{ yr}) \right) \times BW_{\text{out}}(80 \text{ kg})}{\left(\frac{\text{RBA}}{\text{RfDo} \left(\frac{\text{mg}}{\text{kg-day}} \right)} \right) \times \left(\frac{10^{-6} \text{ kg}}{\text{mg}} \right) \times EF_{\text{out}} \left(\frac{225 \text{ days}}{\text{yr}} \right) \times ED_{\text{out}}(25 \text{ yr}) \times IRS_{\text{out}} \left(\frac{100 \text{ mg}}{\text{day}} \right)}$$

- dermal exposure

$$SL_{\text{out-sol-derm}} \left(\frac{\text{mg}}{\text{kg}} \right) = \frac{\text{THQ} \times AT_{\text{out-a}} \left(\frac{365 \text{ days}}{\text{yr}} \times ED_{\text{out}}(25 \text{ yr}) \right) \times BW_{\text{out}}(80 \text{ kg})}{\left(\frac{1}{\text{RfDo} \left(\frac{\text{mg}}{\text{kg-day}} \right) \times \text{GIABS}} \right) \times \left(\frac{10^{-6} \text{ kg}}{\text{mg}} \right) \times EF_{\text{out}} \left(\frac{225 \text{ days}}{\text{yr}} \right) \times ED_{\text{out}}(25 \text{ yr}) \times SA_{\text{out}} \left(\frac{3,527 \text{ cm}^2}{\text{day}} \right) \times AF_{\text{out}} \left(\frac{0.12 \text{ mg}}{\text{cm}^2} \right) \times ABS_d}$$

- inhalation of volatiles and particulates emitted from soil

$$SL_{\text{out-sol-inhn}} \left(\frac{\text{mg}}{\text{kg}} \right) = \frac{\text{THQ} \times AT_{\text{out-a}} \left(\frac{365 \text{ days}}{\text{yr}} \times ED_{\text{out}}(25 \text{ yr}) \right)}{\left(\frac{1}{\text{RfC} \left(\frac{\text{mg}}{\text{m}^3} \right)} \right) \times EF_{\text{out}} \left(\frac{225 \text{ days}}{\text{yr}} \right) \times ED_{\text{out}}(25 \text{ yr}) \times ET_{\text{out}} \left(\frac{8 \text{ hrs}}{\text{day}} \right) \times \left(\frac{1 \text{ day}}{24 \text{ hrs}} \right) \times \left(\frac{1}{VF_{\text{ulim}} \left(\frac{\text{m}^3}{\text{kg}} \right)} + \frac{1}{PEF \left(\frac{\text{m}^3}{\text{kg}} \right)} \right)}$$

- Total

$$SL_{\text{out-sol-totn}} \left(\frac{\text{mg}}{\text{kg}} \right) = \frac{1}{\frac{1}{PRG_{\text{out-sol-ingn}}} + \frac{1}{PRG_{\text{out-sol-inhn}}} + \frac{1}{PRG_{\text{out-sol-dern}}}}$$

4.3.1.2 Carcinogenic

The outdoor worker soil land use equation, presented here, contains the following exposure routes:

- incidental ingestion of soil,

$$SL_{\text{out-sol-ingc}} \left(\frac{\text{mg}}{\text{kg}} \right) = \frac{TR \times AT_{\text{out}} \left(\frac{365 \text{ days}}{\text{yr}} \times LT(70 \text{ yrs}) \right) \times BW_{\text{out}} (80 \text{ kg})}{CSF_o \left(\frac{\text{mg}}{\text{kg-day}} \right)^{-1} \times \left(\frac{10^{-6} \text{ kg}}{\text{mg}} \right) \times RBA \times EF_{\text{out}} \left(\frac{225 \text{ days}}{\text{yr}} \right) \times ED_{\text{out}} (25 \text{ yr}) \times IRS_{\text{out}} \left(\frac{100 \text{ mg}}{\text{day}} \right)}$$

- dermal exposure,

$$SL_{\text{out-sol-derc}} \left(\frac{\text{mg}}{\text{kg}} \right) = \frac{TR \times AT_{\text{out}} \left(\frac{365 \text{ days}}{\text{yr}} \times LT(70 \text{ yrs}) \right) \times BW_{\text{out}} (80 \text{ kg})}{\left(\frac{CSF_o \left(\frac{\text{mg}}{\text{kg-day}} \right)^{-1}}{GIABS} \right) \times \left(\frac{10^{-6} \text{ kg}}{\text{mg}} \right) \times EF_{\text{out}} \left(\frac{225 \text{ days}}{\text{yr}} \right) \times ED_{\text{out}} (25 \text{ yr}) \times SA_{\text{out}} \left(\frac{3,527 \text{ cm}^2}{\text{day}} \right) \times AF_{\text{out}} \left(\frac{0.12 \text{ mg}}{\text{cm}^2} \right) \times ABS_d}$$

- inhalation of volatiles and particulates emitted from soil,

$$SL_{\text{out-sol-inhc}} \left(\frac{\text{mg}}{\text{kg}} \right) = \frac{TR \times AT_{\text{out}} \left(\frac{365 \text{ days}}{\text{yr}} \times LT(70 \text{ yrs}) \right)}{IUR \left(\frac{\mu\text{g}}{\text{m}^3} \right)^{-1} \times \left(\frac{1000 \mu\text{g}}{\text{mg}} \right) \times EF_{\text{out}} \left(\frac{225 \text{ days}}{\text{yr}} \right) \times ED_{\text{out}} (25 \text{ yr}) \times ET_{\text{out}} \left(\frac{8 \text{ hrs}}{\text{day}} \right) \times \left(\frac{1 \text{ day}}{24 \text{ hrs}} \right) \times \left(\frac{1}{VF_{\text{ulim}} \left(\frac{\text{m}^3}{\text{kg}} \right)} + \frac{1}{PEF \left(\frac{\text{m}^3}{\text{kg}} \right)} \right)}$$

- Total.

$$SL_{\text{out-sol-totc}} \left(\frac{\text{mg}}{\text{kg}} \right) = \frac{1}{\frac{1}{\text{PRG}_{\text{out-sol-ingc}}} + \frac{1}{\text{PRG}_{\text{out-sol-inhc}}} + \frac{1}{\text{PRG}_{\text{out-sol-derc}}}}$$

4.3.2 Outdoor Worker Air

This is a long-term receptor exposed during the work day who is a full-time employee working on-site and spends most of the workday conducting maintenance activities outdoors. The outdoor worker is assumed to be exposed to contaminants via the following pathway: inhalation of ambient air. This land use has no assumptions of how contaminants get into the air and the RSLs derived should be compared to air samples.

The outdoor worker air land use is not provided in the RSL Generic Tables but RSLs can be created by using the Calculator.

4.3.2.1 Noncarcinogenic

The air land use equation, presented here, contains the following exposure routes:

- Inhalation

$$SL_{\text{out-air-inhn}} \left(\frac{\mu\text{g}}{\text{m}^3} \right) = \frac{\text{THQ} \times \text{AT}_{\text{out-a}} \left(\frac{365 \text{ days}}{\text{yr}} \times \text{ED}_{\text{out}}(25 \text{ yr}) \right)}{\left(\frac{1}{\text{RfC}} \left(\frac{\text{mg}}{\text{m}^3} \right) \right) \times \left(\frac{\text{mg}}{1000 \mu\text{g}} \right) \times \text{EF}_{\text{out}} \left(\frac{225 \text{ days}}{\text{yr}} \right) \times \text{ED}_{\text{out}}(25 \text{ yr}) \times \text{ET}_{\text{out}} \left(\frac{8 \text{ hrs}}{\text{day}} \right) \times \left(\frac{1 \text{ day}}{24 \text{ hrs}} \right)}$$

4.3.2.2 Carcinogenic

The air land use equation, presented here, contains the following exposure routes:

- Inhalation

$$SL_{\text{out-air-inhc}} \left(\frac{\mu\text{g}}{\text{m}^3} \right) = \frac{\text{TR} \times \text{AT}_{\text{out}} \left(\frac{365 \text{ days}}{\text{yr}} \times \text{LT}(70 \text{ yrs}) \right)}{\text{IUR} \left(\frac{\mu\text{g}}{\text{m}^3} \right)^{-1} \times \text{EF}_{\text{out}} \left(\frac{225 \text{ days}}{\text{yr}} \right) \times \text{ED}_{\text{out}}(25 \text{ yr}) \times \text{ET}_{\text{out}} \left(\frac{8 \text{ hrs}}{\text{day}} \right) \times \left(\frac{1 \text{ day}}{24 \text{ hrs}} \right)}$$

4.4 Indoor Worker

4.4.1 Indoor Worker Soil

This receptor spends most, if not all, of the workday indoors. Thus, an indoor worker has no direct dermal contact with outdoor soils. This worker may, however, be exposed to contaminants through ingestion of contaminated soils that have been incorporated into indoor dust and inhalation of volatiles and particulates from outside soils. RSLs calculated for this receptor are expected to be protective of both workers engaged in low intensity activities such as office work and those engaged in more strenuous activity (e.g., factory or warehouse workers).

The indoor worker soil land use is not provided in the Generic Tables but RSLs can be created by using the Calculator.

4.4.1.1 Noncarcinogenic

The indoor worker soil land use equation, presented here, contains the following exposure routes:

- incidental ingestion of soil

$$SL_{\text{ind-sol-ingn}} \left(\frac{\text{mg}}{\text{kg}} \right) = \frac{\text{THQ} \times AT_{\text{ind-a}} \left(\frac{365 \text{ days}}{\text{yr}} \times \text{ED}_{\text{ind}} (25 \text{ yr}) \right) \times \text{BW}_{\text{ind}} (80 \text{ kg})}{\left(\frac{\text{RfD}_o \left(\frac{\text{mg}}{\text{kg-day}} \right)}{\text{RfD}_o \left(\frac{\text{mg}}{\text{kg-day}} \right)} \right) \times \left(\frac{10^{-6} \text{ kg}}{\text{mg}} \right) \times \text{EF}_{\text{ind}} \left(\frac{250 \text{ days}}{\text{yr}} \right) \times \text{ED}_{\text{ind}} (25 \text{ yr}) \times \text{IRS}_{\text{ind}} \left(\frac{50 \text{ mg}}{\text{day}} \right)}$$

- inhalation of volatiles and particulates emitted from soil

$$SL_{\text{ind-sol-inhn}} \left(\frac{\text{mg}}{\text{kg}} \right) = \frac{\text{THQ} \times AT_{\text{ind-a}} \left(\frac{365 \text{ days}}{\text{yr}} \times \text{ED}_{\text{ind}} (25 \text{ yr}) \right)}{\left(\frac{1}{\text{RfC} \left(\frac{\text{mg}}{\text{m}^3} \right)} \right) \times \text{EF}_{\text{ind}} \left(\frac{250 \text{ days}}{\text{yr}} \right) \times \text{ED}_{\text{ind}} (25 \text{ yr}) \times \text{ET}_{\text{ind}} \left(\frac{8 \text{ hrs}}{\text{day}} \right) \times \left(\frac{1 \text{ day}}{24 \text{ hrs}} \right) \times \left(\frac{1}{\text{VF}_{\text{ulim}} \left(\frac{\text{m}^3}{\text{kg}} \right)} + \frac{1}{\text{PEF} \left(\frac{\text{m}^3}{\text{kg}} \right)} \right)}$$

- Total

$$SL_{\text{ind-sol-totn}} \left(\frac{\text{mg}}{\text{kg}} \right) = \frac{1}{\frac{1}{\text{PRG}_{\text{ind-sol-ingn}}} + \frac{1}{\text{PRG}_{\text{ind-sol-inhn}}}}$$

4.4.1.2 Carcinogenic

The indoor worker soil land use equation, presented here, contains the following exposure routes:

- incidental ingestion of soil

$$SL_{\text{ind-sol-ingc}} \left(\frac{\text{mg}}{\text{kg}} \right) = \frac{\text{TR} \times \text{AT}_{\text{ind}} \left(\frac{365 \text{ days}}{\text{yr}} \times \text{LT}(70 \text{ yrs}) \right) \times \text{BW}_{\text{ind}} (80 \text{ kg})}{\text{CSF}_o \left(\frac{\text{mg}}{\text{kg-day}} \right)^{-1} \times \left(\frac{10^{-6} \text{ kg}}{\text{mg}} \right) \times \text{RBA} \times \text{EF}_{\text{ind}} \left(\frac{250 \text{ days}}{\text{yr}} \right) \times \text{ED}_{\text{ind}} (25 \text{ yr}) \times \text{IRS}_{\text{ind}} \left(\frac{50 \text{ mg}}{\text{day}} \right)}$$

- inhalation of volatiles and particulates emitted from soil

$$SL_{\text{ind-sol-inhc}} \left(\frac{\text{mg}}{\text{kg}} \right) = \frac{\text{TR} \times \text{AT}_{\text{ind}} \left(\frac{365 \text{ days}}{\text{yr}} \times \text{LT}(70 \text{ yrs}) \right)}{\text{IUR} \left(\frac{\mu\text{g}}{\text{m}^3} \right)^{-1} \times \left(\frac{1000 \mu\text{g}}{\text{mg}} \right) \times \text{EF}_{\text{ind}} \left(\frac{250 \text{ days}}{\text{yr}} \right) \times \text{ED}_{\text{ind}} (25 \text{ yr}) \times \text{ET}_{\text{ind}} \left(\frac{8 \text{ hrs}}{\text{day}} \right) \times \left(\frac{1 \text{ day}}{24 \text{ hrs}} \right) \times \left(\frac{1}{\text{VF}_{\text{ulim}} \left(\frac{\text{m}^3}{\text{kg}} \right)} + \frac{1}{\text{PEF} \left(\frac{\text{m}^3}{\text{kg}} \right)} \right)}$$

- Total

$$SL_{\text{ind-sol-totc}} \left(\frac{\text{mg}}{\text{kg}} \right) = \frac{1}{\frac{1}{\text{PRG}_{\text{ind-sol-ingc}}} + \frac{1}{\text{PRG}_{\text{ind-sol-inhc}}}}$$

4.4.2 Indoor Worker Air

This is a long-term receptor exposed during the work day who is a full-time employee working on-site and spends most of the workday conducting maintenance activities indoors. The indoor worker is assumed to be exposed to contaminants via the following pathway: inhalation of

ambient air. This land use has no assumptions of how contaminants get into the air and the RSLs derived should be compared to air samples.

The indoor worker air land use is not provided in the Generic Tables but RSLs can be created by using the Calculator.

4.4.2.1 Noncarcinogenic

The air land use equation, presented here, contains the following exposure routes:

- Inhalation

$$SL_{\text{ind-air-inhn}} \left(\frac{\mu\text{g}}{\text{m}^3} \right) = \frac{\text{THQ} \times \text{AT}_{\text{ind-a}} \left(\frac{365 \text{ days}}{\text{yr}} \times \text{ED}_{\text{ind}} (25 \text{ yr}) \right)}{\left(\frac{1}{\text{RfC}} \left(\frac{\text{mg}}{\text{m}^3} \right) \right) \times \left(\frac{\text{mg}}{1000 \mu\text{g}} \right) \times \text{EF}_{\text{ind}} \left(\frac{250 \text{ days}}{\text{yr}} \right) \times \text{ED}_{\text{ind}} (25 \text{ yr}) \times \text{ET}_{\text{ind}} \left(\frac{8 \text{ hrs}}{\text{day}} \right) \times \left(\frac{1 \text{ day}}{24 \text{ hrs}} \right)}$$

4.4.2.2 Carcinogenic

The air land use equation, presented here, contains the following exposure routes:

- Inhalation

$$SL_{\text{ind-air-inhc}} \left(\frac{\mu\text{g}}{\text{m}^3} \right) = \frac{\text{TR} \times \text{AT}_{\text{ind}} \left(\frac{365 \text{ days}}{\text{yr}} \times \text{LT} (70 \text{ yrs}) \right)}{\text{IUR} \left(\frac{\mu\text{g}}{\text{m}^3} \right)^{-1} \times \text{EF}_{\text{ind}} \left(\frac{250 \text{ days}}{\text{yr}} \right) \times \text{ED}_{\text{ind}} (25 \text{ yr}) \times \text{ET}_{\text{ind}} \left(\frac{8 \text{ hrs}}{\text{day}} \right) \times \left(\frac{1 \text{ day}}{24 \text{ hrs}} \right)}$$

4.5 Construction Worker

An assessment for the construction worker scenario is described in more detail in the Supplemental Soil Screening Guidance (SSSG, EPA, 2002). Despite the exposure duration of one year, carcinogenic risk is averaged over an assumed lifetime of 70 years, consistent with the assumption that the risk of developing cancer continues even after exposure has stopped. EPA guidance states that the averaging time for noncancer is to be set at the same length as exposure duration, even if the exposure duration is less than one year. For noncancer, the averaging time can be changed to be less than a year by changing the number of weeks worked (EW). Further, the examples given in the SSSG show that the time of traffic (T_t) is equivalent to EF and time of construction (T_c) is the averaging time (length of project).

The particulate emission factor (PEF) and volatilization factor (VF) equations used are unique to this scenario. See Section 4.9 for further information on subchronic VFs and PEFs. The PEFs calculated in these scenarios may predict much higher air concentrations than the standard wind-driven PEFs; however, the inhalation screening level will likely be dominated by the VF in the case of a volatile contaminant. VFs are commonly 5 orders of magnitude more protective than PEFs. Additionally, the ingestion route typically is the driving factor in most RSL calculations. Two types of mechanical soil disturbance are addressed: standard vehicle traffic (unpaved) and other construction activities (wind, grading, dozing, tilling and excavating). In general, the intake and contact rates are all greater than the outdoor worker. Exhibit 5-1 in the supplemental soil screening guidance presents the exposure parameters

The construction worker soil land use is not provided in the Generic Tables but RSLs can be created by using the Calculator.

4.5.1 Construction Worker Soil Exposure to Standard Vehicle Traffic

This is a short-term receptor exposed during the work day working around vehicles suspending dust in the air. The activities for this receptor (e.g., trenching, excavating) typically involve on-site exposure to surface soils. The construction worker is expected to have an elevated soil ingestion rate (330 mg per day) and is assumed to be exposed to contaminants via the following pathways: incidental ingestion of soil, dermal contact with contaminants in soil, inhalation of volatiles and fugitive dust. The only difference between this construction worker and the one described in section 4.5.2 is that this construction worker uses a different PEF. The construction worker soil land use is not provided in the Generic Tables but RSLs can be created by using the Calculator. The construction land use is described in the supplemental soil screening guidance. This land use is limited to an exposure duration of 1 year and is thus, subchronic. Other unique aspects of this scenario are that the PEF is based on mechanical disturbance of the soil. Two types of mechanical soil disturbance are addressed: standard vehicle traffic and other than standard vehicle traffic (e.g. wind, grading, dozing, tilling and excavating). In general, the intakes and contact rates are all greater than the outdoor worker. Exhibit 5-1 in the supplemental soil screening guidance presents the exposure parameters.

4.5.1.1 Noncarcinogenic

The construction worker soil land use equation, presented here, contains the following exposure routes:

- incidental ingestion of soil

$$SL_{\text{con-sol-ingn}} \left(\frac{\text{mg}}{\text{kg}} \right) = \frac{\text{THQ} \times \text{AT}_{\text{con-a}} \left(\text{EW}_{\text{con}} \left(\frac{50 \text{ wks}}{\text{yr}} \right) \times \left(\frac{7 \text{ days}}{\text{wk}} \right) \times \text{ED}_{\text{con}} (1 \text{ yr}) \right) \times \text{BW}_{\text{con}} (80 \text{ kg})}{\left(\frac{\text{RBA}}{\text{RfDo}} \left(\frac{\text{mg}}{\text{kg-day}} \right) \right) \times \left(\frac{10^{-6} \text{ kg}}{\text{mg}} \right) \times \text{EF}_{\text{con}} \left(\text{EW}_{\text{con}} \left(\frac{50 \text{ wks}}{\text{yr}} \right) \times \text{DW}_{\text{con}} \left(\frac{5 \text{ days}}{\text{wk}} \right) \right) \times \text{ED}_{\text{con}} (1 \text{ yr}) \times \text{IRS}_{\text{con}} \left(\frac{330 \text{ mg}}{\text{day}} \right)}$$

- dermal exposure

$$SL_{\text{con-sol-dern}} \left(\frac{\text{mg}}{\text{kg}} \right) = \frac{\text{THQ} \times \text{AT}_{\text{con-a}} \left(\text{EW}_{\text{con}} \left(\frac{50 \text{ wks}}{\text{yr}} \right) \times \left(\frac{7 \text{ days}}{\text{wk}} \right) \times \text{ED}_{\text{con}} (1 \text{ yr}) \right) \times \text{BW}_{\text{con}} (80 \text{ kg})}{\left(\frac{1}{\text{RfDo}} \left(\frac{\text{mg}}{\text{kg-day}} \right) \times \text{GIABS} \right) \times \left(\frac{10^{-6} \text{ kg}}{\text{mg}} \right) \times \text{EF}_{\text{con}} \left(\text{EW}_{\text{con}} \left(\frac{50 \text{ wks}}{\text{yr}} \right) \times \text{DW}_{\text{con}} \left(\frac{5 \text{ days}}{\text{wk}} \right) \right) \times \text{ED}_{\text{con}} (1 \text{ yr}) \times \text{SA}_{\text{con}} \left(\frac{3,527 \text{ cm}^2}{\text{day}} \right) \times \text{AF}_{\text{con}} \left(\frac{0.3 \text{ mg}}{\text{cm}^2} \right) \times \text{ABS}_{\text{d}}}$$

- inhalation of volatiles and particulates emitted from soil

$$SL_{\text{con-sol-inhn}} \left(\frac{\text{mg}}{\text{kg}} \right) = \frac{\text{THQ} \times \text{AT}_{\text{con-a}} \left(\text{EW}_{\text{con}} \left(\frac{50 \text{ wks}}{\text{yr}} \right) \times \left(\frac{7 \text{ days}}{\text{wk}} \right) \times \text{ED}_{\text{con}} (1 \text{ yr}) \right)}{\left(\frac{1}{\text{RfC}} \left(\frac{\text{mg}}{\text{m}^3} \right) \right) \times \text{EF}_{\text{con}} \left(\text{EW}_{\text{con}} \left(\frac{50 \text{ wks}}{\text{yr}} \right) \times \text{DW}_{\text{con}} \left(\frac{5 \text{ days}}{\text{wk}} \right) \right) \times \text{ED}_{\text{con}} (1 \text{ yr}) \times \text{ET}_{\text{con}} \left(\frac{8 \text{ hrs}}{\text{day}} \right) \times \left(\frac{1 \text{ day}}{24 \text{ hrs}} \right) \times \left(\frac{1}{\text{VF}_{\text{ulim}}} \left(\frac{\text{m}^3}{\text{kg}} \right) + \frac{1}{\text{PEF}_{\text{sc}}} \left(\frac{\text{m}^3}{\text{kg}} \right) \right)}$$

- Total

$$SL_{\text{con-sol-totn}} \left(\frac{\text{mg}}{\text{kg}} \right) = \frac{1}{\frac{1}{\text{PRG}_{\text{con-sol-ingn}}} + \frac{1}{\text{PRG}_{\text{con-sol-inhn}}} + \frac{1}{\text{PRG}_{\text{con-sol-dern}}}}$$

4.5.1.2 Carcinogenic

The construction worker soil land use equation, presented here, contains the following exposure routes:

- incidental ingestion of soil,

$$SL_{\text{con-sol-ingc}} \left(\frac{\text{mg}}{\text{kg}} \right) = \frac{\text{TR} \times \text{AT}_{\text{con}} \left(\frac{365 \text{ days}}{\text{yr}} \times \text{LT} (70 \text{ yrs}) \right) \times \text{BW}_{\text{con}} (80 \text{ kg})}{\text{CSF}_o \left(\frac{\text{mg}}{\text{kg-day}} \right)^{-1} \times \left(\frac{10^{-6} \text{ kg}}{\text{mg}} \right) \times \text{RBA} \times \text{EF}_{\text{con}} \left(\text{EW}_{\text{con}} \left(\frac{50 \text{ wks}}{\text{yr}} \right) \times \text{DW}_{\text{con}} \left(\frac{5 \text{ days}}{\text{wk}} \right) \right) \times \text{ED}_{\text{con}} (1 \text{ yr}) \times \text{IRS}_{\text{con}} \left(\frac{330 \text{ mg}}{\text{day}} \right)}$$

- dermal exposure,

$$SL_{\text{con-sol-derc}} \left(\frac{\text{mg}}{\text{kg}} \right) = \frac{TR \times AT_{\text{con}} \left(\frac{365 \text{ days}}{\text{yr}} \times LT(70 \text{ yrs}) \right) \times BW_{\text{con}} (80 \text{ kg})}{\left(\frac{CSF_o \left(\frac{\text{mg}}{\text{kg-day}} \right)^{-1}}{GIABS} \right) \times \left(\frac{10^{-6} \text{ kg}}{\text{mg}} \right) \times EF_{\text{con}} \left(EW_{\text{con}} \left(\frac{50 \text{ wks}}{\text{yr}} \right) \times DW_{\text{con}} \left(\frac{5 \text{ days}}{\text{wk}} \right) \right) \times ED_{\text{con}} (1 \text{ yr}) \times SA_{\text{con}} \left(\frac{3,527 \text{ cm}^2}{\text{day}} \right) \times AF_{\text{con}} \left(\frac{0.3 \text{ mg}}{\text{cm}^2} \right) \times ABS_d}$$

- inhalation of volatiles and particulates emitted from soil,

$$SL_{\text{con-sol-inhc}} \left(\frac{\text{mg}}{\text{kg}} \right) = \frac{TR \times AT_{\text{con}} \left(\frac{365 \text{ days}}{\text{yr}} \times LT(70 \text{ yrs}) \right)}{IUR \left(\frac{\mu\text{g}}{\text{m}^3} \right)^{-1} \times \left(\frac{1000 \mu\text{g}}{\text{mg}} \right) \times EF_{\text{con}} \left(EW_{\text{con}} \left(\frac{50 \text{ wks}}{\text{yr}} \right) \times DW_{\text{con}} \left(\frac{5 \text{ days}}{\text{wk}} \right) \right) \times ED_{\text{con}} (1 \text{ yr}) \times ET_{\text{con}} \left(\frac{8 \text{ hrs}}{\text{day}} \right) \times \left(\frac{1 \text{ day}}{24 \text{ hrs}} \right) \times \left(\frac{1}{VF_{\text{ulim}} \left(\frac{\text{m}^3}{\text{kg}} \right)} + \frac{1}{PEF_{\text{sc}} \left(\frac{\text{m}^3}{\text{kg}} \right)} \right)}$$

- Total.

$$SL_{\text{con-sol-totc}} \left(\frac{\text{mg}}{\text{kg}} \right) = \frac{1}{\frac{1}{PRG_{\text{con-sol-ingc}}} + \frac{1}{PRG_{\text{con-sol-inhc}}} + \frac{1}{PRG_{\text{con-sol-derc}}}}$$

4.5.2 Construction Worker Soil Exposure to Other Construction Activities

This is a short-term receptor exposed during the work day working around heavy vehicles suspending dust in the air. The activities for this receptor (e.g., dozing, grading, tilling, dumping, and excavating) typically involve on-site exposure to surface soils. The construction worker is expected to have an elevated soil ingestion rate (330 mg per day) and is assumed to be exposed to contaminants via the following pathways: incidental ingestion of soil, dermal contact with contaminants in soil, inhalation of volatiles and fugitive dust. The only difference between this construction worker and the one described in section 4.5.1 is that this construction worker uses a different PEF. The construction worker soil land use is not provided in the Generic Tables but RSLs can be created by using the Calculator. The construction land use is described in the supplemental soil screening guidance. This land use is limited to an exposure duration of 1 year and is thus, subchronic. Other unique aspects of this scenario are that the PEF is based on mechanical disturbance of the soil. Two types of mechanical soil disturbance are addressed: standard vehicle traffic and other than standard vehicle traffic (e.g. wind, grading, dozing, tilling and excavating). In general, the intakes and contact rates are all greater than the outdoor worker. Exhibit 5-1 in the supplemental soil screening guidance presents the exposure parameters.

4.5.2.1 Noncarcinogenic

The construction worker soil land use equation, presented here, contains the following exposure routes:

- incidental ingestion of soil

$$SL_{\text{con-sol-ingnsa}} \left(\frac{\text{mg}}{\text{kg}} \right) = \frac{\text{THQ} \times \text{AT}_{\text{con-a}} \left(\text{EW}_{\text{con}} \left(\frac{50 \text{ wks}}{\text{yr}} \right) \times \left(\frac{7 \text{ days}}{\text{wk}} \right) \times \text{ED}_{\text{con}}(1 \text{ yr}) \right) \times \text{BW}_{\text{con}}(80 \text{ kg})}{\left(\frac{\text{RBA}}{\text{RfD}_o \left(\frac{\text{mg}}{\text{kg-day}} \right)} \right) \times \left(\frac{10^{-6} \text{ kg}}{\text{mg}} \right) \times \text{EF}_{\text{con}} \left(\text{EW}_{\text{con}} \left(\frac{50 \text{ wks}}{\text{yr}} \right) \times \text{DW}_{\text{con}} \left(\frac{5 \text{ days}}{\text{wk}} \right) \right) \times \text{ED}_{\text{con}}(1 \text{ yr}) \times \text{IRS}_{\text{con}} \left(\frac{330 \text{ mg}}{\text{day}} \right)}$$

- dermal exposure

$$SL_{\text{con-sol-dernsa}} \left(\frac{\text{mg}}{\text{kg}} \right) = \frac{\text{THQ} \times \text{AT}_{\text{con-a}} \left(\text{EW}_{\text{con}} \left(\frac{50 \text{ wks}}{\text{yr}} \right) \times \left(\frac{7 \text{ days}}{\text{wk}} \right) \times \text{ED}_{\text{con}}(1 \text{ yr}) \right) \times \text{BW}_{\text{con}}(80 \text{ kg})}{\left(\frac{1}{\text{RfD}_o \left(\frac{\text{mg}}{\text{kg-day}} \right) \times \text{GIABS}} \right) \times \left(\frac{10^{-6} \text{ kg}}{\text{mg}} \right) \times \text{EF}_{\text{con}} \left(\text{EW}_{\text{con}} \left(\frac{50 \text{ wks}}{\text{yr}} \right) \times \text{DW}_{\text{con}} \left(\frac{5 \text{ days}}{\text{wk}} \right) \right) \times \text{ED}_{\text{con}}(1 \text{ yr}) \times \text{SA}_{\text{con}} \left(\frac{3,527 \text{ cm}^2}{\text{day}} \right) \times \text{AF}_{\text{con}} \left(\frac{0.3 \text{ mg}}{\text{cm}^2} \right) \times \text{ABS}_d}$$

- inhalation of volatiles and particulates emitted from soil

$$SL_{\text{con-sol-inhnsa}} \left(\frac{\text{mg}}{\text{kg}} \right) = \frac{\text{THQ} \times \text{AT}_{\text{con-a}} \left(\text{EW}_{\text{con}} \left(\frac{50 \text{ wks}}{\text{yr}} \right) \times \left(\frac{7 \text{ days}}{\text{wk}} \right) \times \text{ED}_{\text{con}}(1 \text{ yr}) \right)}{\left(\frac{1}{\text{RfC} \left(\frac{\text{mg}}{\text{m}^3} \right)} \right) \times \text{EF}_{\text{con}} \left(\text{EW}_{\text{con}} \left(\frac{50 \text{ wks}}{\text{yr}} \right) \times \text{DW}_{\text{con}} \left(\frac{5 \text{ days}}{\text{wk}} \right) \right) \times \text{ED}_{\text{con}}(1 \text{ yr}) \times \text{ET}_{\text{con}} \left(\frac{8 \text{ hrs}}{\text{day}} \right) \times \left(\frac{1 \text{ day}}{24 \text{ hrs}} \right) \times \left(\frac{1}{\text{VF}_{\text{ulim}} \left(\frac{\text{m}^3}{\text{kg}} \right)} + \frac{1}{\text{PEF}'_{\text{sc}} \left(\frac{\text{m}^3}{\text{kg}} \right)} \right)}$$

- Total

$$SL_{\text{con-sol-totnsa}} \left(\frac{\text{mg}}{\text{kg}} \right) = \frac{1}{\frac{1}{\text{PRG}_{\text{con-sol-ingnsa}}} + \frac{1}{\text{PRG}_{\text{con-sol-inhnsa}}} + \frac{1}{\text{PRG}_{\text{con-sol-dernsa}}}}$$

4.5.2.2 Carcinogenic

The construction worker soil land use equation, presented here, contains the following exposure routes:

- incidental ingestion of soil

$$SL_{\text{con-sol-ingcsa}} \left(\frac{\text{mg}}{\text{kg}} \right) = \frac{TR \times AT_{\text{con}} \left(\frac{365 \text{ days}}{\text{yr}} \times LT(70 \text{ yrs}) \right) \times BW_{\text{con}} (80 \text{ kg})}{CSF_o \left(\frac{\text{mg}}{\text{kg-day}} \right)^{-1} \times \left(\frac{10^{-6} \text{ kg}}{\text{mg}} \right) \times RBA \times EF_{\text{con}} \left(EW_{\text{con}} \left(\frac{50 \text{ wks}}{\text{yr}} \right) \times DW_{\text{con}} \left(\frac{5 \text{ days}}{\text{wk}} \right) \right) \times ED_{\text{con}} (1 \text{ yr}) \times IRS_{\text{con}} \left(\frac{330 \text{ mg}}{\text{day}} \right)}$$

- dermal exposure

$$SL_{\text{con-sol-dercsa}} \left(\frac{\text{mg}}{\text{kg}} \right) = \frac{TR \times AT_{\text{con}} \left(\frac{365 \text{ days}}{\text{yr}} \times LT(70 \text{ yrs}) \right) \times BW_{\text{con}} (80 \text{ kg})}{\left(\frac{CSF_o \left(\frac{\text{mg}}{\text{kg-day}} \right)^{-1}}{GIABS} \right) \times \left(\frac{10^{-6} \text{ kg}}{\text{mg}} \right) \times EF_{\text{con}} \left(EW_{\text{con}} \left(\frac{50 \text{ wks}}{\text{yr}} \right) \times DW_{\text{con}} \left(\frac{5 \text{ days}}{\text{wk}} \right) \right) \times ED_{\text{con}} (1 \text{ yr}) \times SA_{\text{con}} \left(\frac{3,527 \text{ cm}^2}{\text{day}} \right) \times AF_{\text{con}} \left(\frac{0.3 \text{ mg}}{\text{cm}^2} \right) \times ABS_d}$$

- inhalation of volatiles and particulates emitted from soil

$$SL_{\text{con-sol-inhcsa}} \left(\frac{\text{mg}}{\text{kg}} \right) = \frac{TR \times AT_{\text{con}} \left(\frac{365 \text{ days}}{\text{yr}} \times LT(70 \text{ yrs}) \right)}{IUR \left(\frac{\mu\text{g}}{\text{m}^3} \right)^{-1} \times \left(\frac{1000 \mu\text{g}}{\text{mg}} \right) \times EF_{\text{con}} \left(EW_{\text{con}} \left(\frac{50 \text{ wks}}{\text{yr}} \right) \times DW_{\text{con}} \left(\frac{5 \text{ days}}{\text{wk}} \right) \right) \times ED_{\text{con}} (1 \text{ yr}) \times ET_{\text{con}} \left(\frac{8 \text{ hrs}}{\text{day}} \right) \times \left(\frac{1 \text{ day}}{24 \text{ hrs}} \right) \times \left(\frac{1}{VF_{\text{ulim}}} \left(\frac{\text{m}^3}{\text{kg}} \right) + \frac{1}{PEF_{\text{sc}}} \left(\frac{\text{m}^3}{\text{kg}} \right) \right)}$$

- Total

$$SL_{\text{con-sol-totcsa}} \left(\frac{\text{mg}}{\text{kg}} \right) = \frac{1}{\frac{1}{PRG_{\text{con-sol-ingcsa}}} + \frac{1}{PRG_{\text{con-sol-inhcsa}}} + \frac{1}{PRG_{\text{con-sol-dercsa}}}}$$

4.6 Recreator

4.6.1 Recreator Soil or Sediment

This receptor spends time outside involved in recreational activities. The recreator is assumed to be exposed to contaminants via the following pathways: incidental ingestion of soil, dermal contact with contaminants in soil, and inhalation of volatiles and fugitive dust. There are no default RSLs for this scenario; only site-specific.

The recreator soil land use is not provided in the Generic Tables but RSLs can be created by using the Calculator.

4.6.1.1 Noncarcinogenic - Child

The recreator soil or sediment land use equation, presented here, contains the following exposure routes:

- incidental ingestion of soil or sediment

$$SL_{\text{rec-sol-ingnc}} \left(\frac{\text{mg}}{\text{kg}} \right) = \frac{\text{THQ} \times \text{AT}_{\text{rec-c}} \left(\frac{365 \text{ days}}{\text{yr}} \times \text{ED}_{\text{rec-c}} (6 \text{ yr}) \right) \times \text{BW}_{\text{rec-c}} (15 \text{ kg})}{\left(\frac{\text{RBA}}{\text{RfD}_o \left(\frac{\text{mg}}{\text{kg-day}} \right)} \right) \times \left(\frac{10^{-6} \text{ kg}}{\text{mg}} \right) \times \text{EF}_{\text{rec-c}} \left(\frac{\text{days}}{\text{yr}} \right) \times \text{ED}_{\text{rec-c}} (6 \text{ yr}) \times \text{IRS}_{\text{rec-c}} \left(\frac{\text{mg}}{\text{day}} \right)}$$

- dermal contact with soil or sediment

$$SL_{\text{rec-sol-dernc}} \left(\frac{\text{mg}}{\text{kg}} \right) = \frac{\text{THQ} \times \text{AT}_{\text{rec-c}} \left(\frac{365 \text{ days}}{\text{yr}} \times \text{ED}_{\text{rec-c}} (6 \text{ yr}) \right) \times \text{BW}_{\text{rec-c}} (15 \text{ kg})}{\left(\frac{1}{\text{RfD}_o \left(\frac{\text{mg}}{\text{kg-day}} \right) \times \text{GIABS}} \right) \times \left(\frac{10^{-6} \text{ kg}}{\text{mg}} \right) \times \text{EF}_{\text{rec-c}} \left(\frac{\text{days}}{\text{yr}} \right) \times \text{ED}_{\text{rec-c}} (6 \text{ yr}) \times \text{SA}_{\text{rec-c}} \left(\frac{\text{cm}^2}{\text{day}} \right) \times \text{AF}_{\text{rec-c}} \left(\frac{\text{mg}}{\text{cm}^2} \right) \times \text{ABS}_d}$$

- inhalation of volatiles and particulates emitted from soil or sediment

$$SL_{\text{rec-sol-inhnc}} \left(\frac{\text{mg}}{\text{kg}} \right) = \frac{\text{THQ} \times \text{AT}_{\text{rec-c}} \left(\frac{365 \text{ days}}{\text{yr}} \times \text{ED}_{\text{rec-c}} (6 \text{ yr}) \right)}{\left(\frac{1}{\text{RfC} \left(\frac{\text{mg}}{\text{m}^3} \right)} \right) \times \text{EF}_{\text{rec-c}} \left(\frac{\text{days}}{\text{yr}} \right) \times \text{ED}_{\text{rec-c}} (6 \text{ yr}) \times \text{ET}_{\text{rec-c}} \left(\frac{\text{hrs}}{\text{day}} \right) \times \left(\frac{1 \text{ day}}{24 \text{ hrs}} \right) \times \left(\frac{1}{\text{VF}_{\text{ulim}} \left(\frac{\text{m}^3}{\text{kg}} \right)} + \frac{1}{\text{PEF} \left(\frac{\text{m}^3}{\text{kg}} \right)} \right)}$$

- Total

$$SL_{\text{rec-sol-totnc}} \left(\frac{\text{mg}}{\text{kg}} \right) = \frac{1}{\frac{1}{SL_{\text{rec-sol-ingnc}}} + \frac{1}{SL_{\text{rec-sol-inhnc}}} + \frac{1}{SL_{\text{rec-sol-dernc}}}}$$

4.6.1.2 Noncarcinogenic - Adult

The recreator soil or sediment land use equation, presented here, contains the following exposure routes:

- incidental ingestion of soil or sediment

$$SL_{\text{rec-sol-ingna}} \left(\frac{\text{mg}}{\text{kg}} \right) = \frac{\text{THQ} \times \text{AT}_{\text{rec-a}} \left(\frac{365 \text{ days}}{\text{yr}} \times \text{ED}_{\text{rec}} (26 \text{ yr}) \right) \times \text{BW}_{\text{rec-a}} (80 \text{ kg})}{\left(\frac{\text{RBA}}{\text{RfDo}} \left(\frac{\text{mg}}{\text{kg-day}} \right) \right) \times \left(\frac{10^{-6} \text{ kg}}{\text{mg}} \right) \times \text{EF}_{\text{rec-a}} \left(\frac{\text{days}}{\text{yr}} \right) \times \text{ED}_{\text{rec}} (26 \text{ yr}) \times \text{IRS}_{\text{rec-a}} \left(\frac{\text{mg}}{\text{day}} \right)}$$

- dermal contact with soil or sediment

$$SL_{\text{rec-sol-derma}} \left(\frac{\text{mg}}{\text{kg}} \right) = \frac{\text{THQ} \times \text{AT}_{\text{rec-a}} \left(\frac{365 \text{ days}}{\text{yr}} \times \text{ED}_{\text{rec}} (26 \text{ yr}) \right) \times \text{BW}_{\text{rec-a}} (80 \text{ kg})}{\left(\frac{1}{\text{RfDo}} \left(\frac{\text{mg}}{\text{kg-day}} \right) \times \text{GIABS} \right) \times \left(\frac{10^{-6} \text{ kg}}{\text{mg}} \right) \times \text{EF}_{\text{rec-a}} \left(\frac{\text{days}}{\text{yr}} \right) \times \text{ED}_{\text{rec}} (26 \text{ yr}) \times \text{SA}_{\text{rec-a}} \left(\frac{\text{cm}^2}{\text{day}} \right) \times \text{AF}_{\text{rec-a}} \left(\frac{\text{mg}}{\text{cm}^2} \right) \times \text{ABS}_d}$$

- inhalation of volatiles and particulates emitted from soil or sediment

$$SL_{\text{rec-sol-inhna}} \left(\frac{\text{mg}}{\text{kg}} \right) = \frac{\text{THQ} \times \text{AT}_{\text{rec-a}} \left(\frac{365 \text{ days}}{\text{yr}} \times \text{ED}_{\text{rec}} (26 \text{ yr}) \right)}{\left(\frac{1}{\text{RfC}} \left(\frac{\text{mg}}{\text{m}^3} \right) \right) \times \text{EF}_{\text{rec-a}} \left(\frac{\text{days}}{\text{yr}} \right) \times \text{ED}_{\text{rec}} (26 \text{ yr}) \times \text{ET}_{\text{rec-a}} \left(\frac{\text{hrs}}{\text{day}} \right) \times \left(\frac{1 \text{ day}}{24 \text{ hrs}} \right) \times \left(\frac{1}{\text{VF}_{\text{ulim}}} \left(\frac{\text{m}^3}{\text{kg}} \right) + \frac{1}{\text{PEF}} \left(\frac{\text{m}^3}{\text{kg}} \right) \right)}$$

- Total

$$SL_{\text{rec-sol-totna}} \left(\frac{\text{mg}}{\text{kg}} \right) = \frac{1}{\frac{1}{SL_{\text{rec-sol-ingna}}} + \frac{1}{SL_{\text{rec-sol-inhna}}} + \frac{1}{SL_{\text{rec-sol-derma}}}}$$

4.6.1.3 Carcinogenic

The recreator soil or sediment land use equation, presented here, contains the following exposure routes:

- incidental ingestion of soil or sediment

$$SL_{\text{rec-sol-ingc}} \left(\frac{\text{mg}}{\text{kg}} \right) = \frac{TR \times AT_{\text{rec}} \left(\frac{365 \text{ days}}{\text{yr}} \times LT(70 \text{ yrs}) \right)}{CSF_o \left(\frac{\text{mg}}{\text{kg-day}} \right)^{-1} \times \left(\frac{10^{-6} \text{ kg}}{\text{mg}} \right) \times RBA \times IFS_{\text{rec-adj}} \left(\frac{\text{mg}}{\text{kg}} \right)}$$

where:

$$IFS_{\text{rec-adj}} \left(\frac{\text{mg}}{\text{kg}} \right) = \left[\frac{EF_{\text{rec-c}} \left(\frac{\text{days}}{\text{yr}} \right) \times ED_{\text{rec-c}}(6 \text{ yr}) \times IRS_{\text{rec-c}} \left(\frac{\text{mg}}{\text{day}} \right)}{BW_{\text{rec-c}}(15 \text{ kg})} + \frac{EF_{\text{rec-a}} \left(\frac{\text{days}}{\text{yr}} \right) \times ED_{\text{rec-a}}(20 \text{ yr}) \times IRS_{\text{rec-a}} \left(\frac{\text{mg}}{\text{day}} \right)}{BW_{\text{rec-a}}(80 \text{ kg})} \right]$$

- dermal contact with soil or sediment

$$SL_{\text{rec-sol-derc}} \left(\frac{\text{mg}}{\text{kg}} \right) = \frac{TR \times AT_{\text{rec}} \left(\frac{365 \text{ days}}{\text{yr}} \times LT(70 \text{ yrs}) \right)}{\left(\frac{CSF_o \left(\frac{\text{mg}}{\text{kg-day}} \right)^{-1}}{GIABS} \right) \times \left(\frac{10^{-6} \text{ kg}}{\text{mg}} \right) \times DFS_{\text{rec-adj}} \left(\frac{\text{mg}}{\text{kg}} \right) \times ABS_d}$$

where:

$$DFS_{\text{rec-adj}} \left(\frac{\text{mg}}{\text{kg}} \right) = \left[\frac{EF_{\text{rec-c}} \left(\frac{\text{days}}{\text{yr}} \right) \times ED_{\text{rec-c}}(6 \text{ yr}) \times SA_{\text{rec-c}} \left(\frac{\text{cm}^2}{\text{day}} \right) \times AF_{\text{rec-c}} \left(\frac{\text{mg}}{\text{cm}^2} \right)}{BW_{\text{rec-c}}(15 \text{ kg})} + \frac{EF_{\text{rec-a}} \left(\frac{\text{days}}{\text{yr}} \right) \times ED_{\text{rec-a}}(20 \text{ yr}) \times SA_{\text{rec-a}} \left(\frac{\text{cm}^2}{\text{day}} \right) \times AF_{\text{rec-a}} \left(\frac{\text{mg}}{\text{cm}^2} \right)}{BW_{\text{rec-a}}(80 \text{ kg})} \right]$$

- inhalation of volatiles and particulates emitted from soil or sediment

$$SL_{\text{rec-sol-inhc}} \left(\frac{\text{mg}}{\text{kg}} \right) = \frac{TR \times AT_{\text{rec}} \left(\frac{365 \text{ days}}{\text{yr}} \times LT(70 \text{ yrs}) \right)}{IUR \left(\frac{\mu\text{g}}{\text{m}^3} \right)^{-1} \times \left(\frac{1000 \mu\text{g}}{\text{mg}} \right) \times EF_{\text{rec}} \left(\frac{\text{days}}{\text{yr}} \right) \times ED_{\text{rec}}(26 \text{ yr}) \times ET_{\text{rec}} \left(\frac{\text{hrs}}{\text{day}} \right) \times \left(\frac{1 \text{ day}}{24 \text{ hrs}} \right) \times \left(\frac{1}{VF_{\text{ulim}} \left(\frac{\text{m}^3}{\text{kg}} \right)} + \frac{1}{PEF \left(\frac{\text{m}^3}{\text{kg}} \right)} \right)}$$

- Total

$$SL_{\text{rec-sol-totc}} \left(\frac{\text{mg}}{\text{kg}} \right) = \frac{1}{\frac{1}{SL_{\text{rec-sol-ingc}}} + \frac{1}{SL_{\text{rec-sol-inhc}}} + \frac{1}{SL_{\text{rec-sol-derc}}}}$$

4.6.1.4 Mutagenic

The recreator soil or sediment land use equation, presented here, contains the following exposure routes:

- incidental ingestion of soil or sediment,

$$SL_{\text{rec-sol-ingmu}} \left(\frac{\text{mg}}{\text{kg}} \right) = \frac{TR \times AT_{\text{rec}} \left(\frac{365 \text{ days}}{\text{yr}} \times LT(70 \text{ yrs}) \right)}{CSF_o \left(\frac{\text{mg}}{\text{kg-day}} \right)^{-1} \times \left(\frac{10^{-6} \text{ kg}}{\text{mg}} \right) \times RBA \times \text{IFSM}_{\text{rec-adj}} \left(\frac{\text{mg}}{\text{kg}} \right)}$$

where:

$$\text{IFSM}_{\text{rec-adj}} \left(\frac{\text{mg}}{\text{kg}} \right) = \left[\begin{array}{l} \frac{EF_{0-2} \left(\frac{\text{days}}{\text{yr}} \right) \times ED_{0-2} (2 \text{ yr}) \times IRS_{0-2} \left(\frac{\text{mg}}{\text{day}} \right) \times 10}{BW_{0-2} (15 \text{ kg})} + \\ \frac{EF_{2-6} \left(\frac{\text{days}}{\text{yr}} \right) \times ED_{2-6} (4 \text{ yr}) \times IRS_{2-6} \left(\frac{\text{mg}}{\text{day}} \right) \times 3}{BW_{2-6} (15 \text{ kg})} + \\ \frac{EF_{6-16} \left(\frac{\text{days}}{\text{yr}} \right) \times ED_{6-16} (10 \text{ yr}) \times IRS_{6-16} \left(\frac{\text{mg}}{\text{day}} \right) \times 3}{BW_{6-16} (80 \text{ kg})} + \\ \frac{EF_{16-26} \left(\frac{\text{days}}{\text{yr}} \right) \times ED_{16-26} (10 \text{ yr}) \times IRS_{16-26} \left(\frac{\text{mg}}{\text{day}} \right) \times 1}{BW_{16-26} (80 \text{ kg})} \end{array} \right]$$

- dermal contact with soil or sediment

$$SL_{\text{rec-sol-dermu}} \left(\frac{\text{mg}}{\text{kg}} \right) = \frac{TR \times AT_{\text{rec}} \left(\frac{365 \text{ days}}{\text{yr}} \times LT(70 \text{ yrs}) \right)}{\left(\frac{CSF_o \left(\frac{\text{mg}}{\text{kg-day}} \right)^{-1}}{GIABS} \right) \times \left(\frac{10^{-6} \text{ kg}}{\text{mg}} \right) \times DFSM_{\text{rec-adj}} \left(\frac{\text{mg}}{\text{kg}} \right) \times ABS_d}$$

where:

$$DFSM_{\text{rec-adj}} \left(\frac{\text{mg}}{\text{kg}} \right) = \left[\begin{array}{l} \frac{EF_{0-2} \left(\frac{\text{days}}{\text{yr}} \right) \times ED_{0-2} (2 \text{ yr}) \times SA_{0-2} \left(\frac{\text{cm}^2}{\text{day}} \right) \times AF_{0-2} \left(\frac{\text{mg}}{\text{cm}^2} \right) \times 10}{BW_{0-2} (15 \text{ kg})} + \\ \frac{EF_{2-6} \left(\frac{\text{days}}{\text{yr}} \right) \times ED_{2-6} (4 \text{ yr}) \times SA_{2-6} \left(\frac{\text{cm}^2}{\text{day}} \right) \times AF_{2-6} \left(\frac{\text{mg}}{\text{cm}^2} \right) \times 3}{BW_{2-6} (15 \text{ kg})} + \\ \frac{EF_{6-16} \left(\frac{\text{days}}{\text{yr}} \right) \times ED_{6-16} (10 \text{ yr}) \times SA_{6-16} \left(\frac{\text{cm}^2}{\text{day}} \right) \times AF_{6-16} \left(\frac{\text{mg}}{\text{cm}^2} \right) \times 3}{BW_{6-16} (80 \text{ kg})} + \\ \frac{EF_{16-26} \left(\frac{\text{days}}{\text{yr}} \right) \times ED_{16-26} (10 \text{ yr}) \times SA_{16-26} \left(\frac{\text{cm}^2}{\text{day}} \right) \times AF_{16-26} \left(\frac{\text{mg}}{\text{cm}^2} \right) \times 1}{BW_{16-26} (80 \text{ kg})} \end{array} \right]$$

- inhalation of volatiles and particulates emitted from soil or sediment

$$SL_{\text{rec-sol-inhmu}} \left(\frac{\text{mg}}{\text{kg}} \right) = \frac{TR \times AT_{\text{rec}} \left(\frac{365 \text{ days}}{\text{yr}} \times LT(70 \text{ yrs}) \right)}{IUR \left(\frac{\mu\text{g}}{\text{m}^3} \right)^{-1} \times \left(\frac{1000 \mu\text{g}}{\text{mg}} \right) \times \left(\frac{1}{VF_{\text{ulim}} \left(\frac{\text{m}^3}{\text{kg}} \right)} + \frac{1}{PEF \left(\frac{\text{m}^3}{\text{kg}} \right)} \right) \times \left[\begin{array}{l} \left(EF_{0-2} \left(\frac{\text{days}}{\text{yr}} \right) \times ED_{0-2} (2 \text{ yr}) \times ET_{0-2} \left(\frac{\text{hrs}}{\text{day}} \right) \times \left(\frac{1 \text{ day}}{24 \text{ hrs}} \right) \times 10 \right) + \\ \left(EF_{2-6} \left(\frac{\text{days}}{\text{yr}} \right) \times ED_{2-6} (4 \text{ yr}) \times ET_{2-6} \left(\frac{\text{hrs}}{\text{day}} \right) \times \left(\frac{1 \text{ day}}{24 \text{ hrs}} \right) \times 3 \right) + \\ \left(EF_{6-16} \left(\frac{\text{days}}{\text{yr}} \right) \times ED_{6-16} (10 \text{ yr}) \times ET_{6-16} \left(\frac{\text{hrs}}{\text{day}} \right) \times \left(\frac{1 \text{ day}}{24 \text{ hrs}} \right) \times 3 \right) + \\ \left(EF_{16-26} \left(\frac{\text{days}}{\text{yr}} \right) \times ED_{16-26} (10 \text{ yr}) \times ET_{16-26} \left(\frac{\text{hrs}}{\text{day}} \right) \times \left(\frac{1 \text{ day}}{24 \text{ hrs}} \right) \times 1 \right) \end{array} \right]}$$

- Total

$$SL_{\text{rec-sol-totmu}} \left(\frac{\text{mg}}{\text{kg}} \right) = \frac{1}{\frac{1}{SL_{\text{rec-sol-ingmu}}} + \frac{1}{SL_{\text{rec-sol-inhmu}}} + \frac{1}{SL_{\text{rec-sol-dermu}}}}$$

4.6.1.5 Vinyl Chloride - Carcinogenic

The recreator soil or sediment land use equations, presented here, contain the following exposure routes:

- incidental ingestion of soil or sediment

$$SL_{\text{rec-sol-ingvc}} \left(\frac{\text{mg}}{\text{kg}} \right) = \frac{\text{TR}}{\left(\frac{\left(\text{CSF}_o \left(\frac{\text{mg}}{\text{kg-day}} \right)^{-1} \times \left(\frac{10^{-6} \text{ kg}}{\text{mg}} \right) \times \text{RBA} \times \text{IFS}_{\text{rec-adj}} \left(\frac{\text{mg}}{\text{kg}} \right) \right)}{\text{AT}_{\text{rec}} \left(\frac{365 \text{ days}}{\text{yr}} \times \text{LT} (70 \text{ yrs}) \right)} \right) + \left(\frac{\left(\text{CSF}_o \left(\frac{\text{mg}}{\text{kg-day}} \right)^{-1} \times \left(\frac{10^{-6} \text{ kg}}{\text{mg}} \right) \times \text{RBA} \times \text{IRS}_{\text{rec-c}} \left(\frac{\text{mg}}{\text{day}} \right) \right)}{\text{BW}_{\text{rec-c}} (15 \text{ kg})} \right) \right)}$$

where:

$$\text{IFS}_{\text{rec-adj}} \left(\frac{\text{mg}}{\text{kg}} \right) = \left[\frac{\text{EF}_{\text{rec-c}} \left(\frac{\text{days}}{\text{yr}} \right) \times \text{ED}_{\text{rec-c}} (6 \text{ yr}) \times \text{IRS}_{\text{rec-c}} \left(\frac{\text{mg}}{\text{day}} \right)}{\text{BW}_{\text{rec-c}} (15 \text{ kg})} + \frac{\text{EF}_{\text{rec-a}} \left(\frac{\text{days}}{\text{yr}} \right) \times \text{ED}_{\text{rec-a}} (20 \text{ yr}) \times \text{IRS}_{\text{rec-a}} \left(\frac{\text{mg}}{\text{day}} \right)}{\text{BW}_{\text{rec-a}} (80 \text{ kg})} \right]$$

- dermal contact with soil or sediment

$$SL_{\text{rec-sol-dervc}} \left(\frac{\text{mg}}{\text{kg}} \right) = \frac{TR}{\left(\frac{\left(\frac{\text{CSF}_o \left(\frac{\text{mg}}{\text{kg-day}} \right)^{-1}}{\text{GIABS}} \times \left(\frac{10^{-6} \text{ kg}}{\text{mg}} \right) \times \text{DFS}_{\text{rec-adj}} \left(\frac{\text{mg}}{\text{kg}} \right) \times \text{ABS}_d}{\text{AT}_{\text{rec}} \left(\frac{365 \text{ days}}{\text{yr}} \times \text{LT}(70 \text{ yrs}) \right)} \right) + \left(\frac{\text{CSF}_o \left(\frac{\text{mg}}{\text{kg-day}} \right)^{-1}}{\text{GIABS}} \times \left(\frac{10^{-6} \text{ kg}}{\text{mg}} \right) \times \text{SA}_{\text{rec-c}} \left(\frac{\text{cm}^2}{\text{day}} \right) \times \text{AF}_{\text{rec-c}} \left(\frac{\text{mg}}{\text{cm}^2} \right) \times \text{ABS}_d}{\text{BW}_{\text{rec-c}} (15 \text{ kg})} \right)}$$

where:

$$\text{DFS}_{\text{rec-adj}} \left(\frac{\text{mg}}{\text{kg}} \right) = \frac{\left(\frac{\text{EF}_{\text{rec-c}} \left(\frac{\text{days}}{\text{yr}} \right) \times \text{ED}_{\text{rec-c}} (6 \text{ yr}) \times \text{SA}_{\text{rec-c}} \left(\frac{\text{cm}^2}{\text{day}} \right) \times \text{AF}_{\text{rec-c}} \left(\frac{\text{mg}}{\text{cm}^2} \right)}{\text{BW}_{\text{rec-c}} (15 \text{ kg})} \right) + \left(\frac{\text{EF}_{\text{rec-a}} \left(\frac{\text{days}}{\text{yr}} \right) \times \text{ED}_{\text{rec-a}} (20 \text{ yr}) \times \text{SA}_{\text{rec-a}} \left(\frac{\text{cm}^2}{\text{day}} \right) \times \text{AF}_{\text{rec-a}} \left(\frac{\text{mg}}{\text{cm}^2} \right)}{\text{BW}_{\text{rec-a}} (80 \text{ kg})} \right)}$$

- inhalation of volatiles and particulates emitted from soil or sediment

$$SL_{\text{rec-sol-inhvc}} \left(\frac{\text{mg}}{\text{kg}} \right) = \frac{TR}{\left(\frac{\left(\frac{\text{IUR} \left(\frac{\mu\text{g}}{\text{m}^3} \right)^{-1} \times \left(\frac{1000 \mu\text{g}}{\text{mg}} \right) \times \text{EF}_{\text{rec}} \left(\frac{\text{days}}{\text{yr}} \right) \times \text{ED}_{\text{rec}} (26 \text{ yr}) \times \text{ET}_{\text{rec}} \left(\frac{\text{hrs}}{\text{day}} \right) \times \left(\frac{1 \text{ day}}{24 \text{ hrs}} \right) \right)}{\text{AT}_{\text{rec}} \left(\frac{365 \text{ days}}{\text{yr}} \times \text{LT}(70 \text{ yrs}) \right) \times \text{VF}_{\text{ulim}} \left(\frac{\text{m}^3}{\text{kg}} \right)} \right) + \left(\frac{\text{IUR} \left(\frac{\mu\text{g}}{\text{m}^3} \right)^{-1} \times \left(\frac{1000 \mu\text{g}}{\text{mg}} \right)}{\text{VF}_{\text{ulim}} \left(\frac{\text{m}^3}{\text{kg}} \right)} \right)}$$

- Total

$$SL_{\text{rec-sol-totvc}} \left(\frac{\text{mg}}{\text{kg}} \right) = \frac{1}{\frac{1}{SL_{\text{rec-sol-ingvc}}} + \frac{1}{SL_{\text{rec-sol-inhvc}}} + \frac{1}{SL_{\text{rec-sol-dervc}}}}$$

4.6.1.6 Trichloroethylene - Carcinogenic and Mutagenic

The recreator soil or sediment land use equations, presented here, contain the following exposure routes:

- incidental ingestion of soil or sediment

$$SL_{\text{rec-sol-ingtce}} \left(\frac{\text{mg}}{\text{kg}} \right) = \frac{TR \times AT_{\text{rec}} \left(\frac{365 \text{ days}}{\text{yr}} \times LT(70 \text{ yrs}) \right)}{CSF_o \left(\frac{\text{mg}}{\text{kg-day}} \right)^{-1} \times \left(\frac{10^{-6} \text{ kg}}{\text{mg}} \right) \times RBA \times \left(\left(CAF_o(0.804) \times IFS_{\text{rec-adj}} \left(\frac{\text{mg}}{\text{kg}} \right) \right) + \left(MAF_o(0.202) \times IFSM_{\text{rec-adj}} \left(\frac{\text{mg}}{\text{kg}} \right) \right) \right)}$$

where:

$$IFS_{\text{rec-adj}} \left(\frac{\text{mg}}{\text{kg}} \right) = \left[\frac{EF_{\text{rec-c}} \left(\frac{\text{days}}{\text{yr}} \right) \times ED_{\text{rec-c}}(6 \text{ yr}) \times IRS_{\text{rec-c}} \left(\frac{\text{mg}}{\text{day}} \right)}{BW_{\text{rec-c}}(15 \text{ kg})} + \frac{EF_{\text{rec-a}} \left(\frac{\text{days}}{\text{yr}} \right) \times ED_{\text{rec-a}}(20 \text{ yr}) \times IRS_{\text{rec-a}} \left(\frac{\text{mg}}{\text{day}} \right)}{BW_{\text{rec-a}}(80 \text{ kg})} \right]$$

and:

$$IFSM_{\text{rec-adj}} \left(\frac{\text{mg}}{\text{kg}} \right) = \left[\frac{EF_{0-2} \left(\frac{\text{days}}{\text{yr}} \right) \times ED_{0-2}(2 \text{ yr}) \times IRS_{0-2} \left(\frac{\text{mg}}{\text{day}} \right) \times 10}{BW_{0-2}(15 \text{ kg})} + \frac{EF_{2-6} \left(\frac{\text{days}}{\text{yr}} \right) \times ED_{2-6}(4 \text{ yr}) \times IRS_{2-6} \left(\frac{\text{mg}}{\text{day}} \right) \times 3}{BW_{2-6}(15 \text{ kg})} + \frac{EF_{6-16} \left(\frac{\text{days}}{\text{yr}} \right) \times ED_{6-16}(10 \text{ yr}) \times IRS_{6-16} \left(\frac{\text{mg}}{\text{day}} \right) \times 3}{BW_{6-16}(80 \text{ kg})} + \frac{EF_{16-26} \left(\frac{\text{days}}{\text{yr}} \right) \times ED_{16-26}(10 \text{ yr}) \times IRS_{16-26} \left(\frac{\text{mg}}{\text{day}} \right) \times 1}{BW_{16-26}(80 \text{ kg})} \right]$$

- dermal contact with soil or sediment

$$SL_{\text{rec-sol-derm}} \left(\frac{\text{mg}}{\text{kg}} \right) = \frac{TR \times AT_{\text{rec}} \left(\frac{365 \text{ days}}{\text{yr}} \times LT(70 \text{ yrs}) \right)}{\left(\frac{CSF_o \left(\frac{\text{mg}}{\text{kg-day}} \right)^{-1}}{GIABS} \right) \times \left(\frac{10^{-6} \text{ kg}}{\text{mg}} \right) \times \left(\left(CAF_o(0.804) \times DFS_{\text{rec-adj}} \left(\frac{\text{mg}}{\text{kg}} \right) \times ABS_d \right) + \left(MAF_o(0.202) \times DFSM_{\text{rec-adj}} \left(\frac{\text{mg}}{\text{kg}} \right) \times ABS_d \right) \right)}$$

where:

$$DFS_{\text{rec-adj}} \left(\frac{\text{mg}}{\text{kg}} \right) = \left[\frac{EF_{\text{rec-c}} \left(\frac{\text{days}}{\text{yr}} \right) \times ED_{\text{rec-c}}(6 \text{ yr}) \times SA_{\text{rec-c}} \left(\frac{\text{cm}^2}{\text{day}} \right) \times AF_{\text{rec-c}} \left(\frac{\text{mg}}{\text{cm}^2} \right)}{BW_{\text{rec-c}}(15 \text{ kg})} + \frac{EF_{\text{rec-a}} \left(\frac{\text{days}}{\text{yr}} \right) \times ED_{\text{rec-a}}(20 \text{ yr}) \times SA_{\text{rec-a}} \left(\frac{\text{cm}^2}{\text{day}} \right) \times AF_{\text{rec-a}} \left(\frac{\text{mg}}{\text{cm}^2} \right)}{BW_{\text{rec-a}}(80 \text{ kg})} \right]$$

and:

$$DFSM_{\text{rec-adj}} \left(\frac{\text{mg}}{\text{kg}} \right) = \left[\frac{EF_{0-2} \left(\frac{\text{days}}{\text{yr}} \right) \times ED_{0-2}(2 \text{ yr}) \times SA_{0-2} \left(\frac{\text{cm}^2}{\text{day}} \right) \times AF_{0-2} \left(\frac{\text{mg}}{\text{cm}^2} \right) \times 10}{BW_{0-2}(15 \text{ kg})} + \frac{EF_{2-6} \left(\frac{\text{days}}{\text{yr}} \right) \times ED_{2-6}(4 \text{ yr}) \times SA_{2-6} \left(\frac{\text{cm}^2}{\text{day}} \right) \times AF_{2-6} \left(\frac{\text{mg}}{\text{cm}^2} \right) \times 3}{BW_{2-6}(15 \text{ kg})} + \frac{EF_{6-16} \left(\frac{\text{days}}{\text{yr}} \right) \times ED_{6-16}(10 \text{ yr}) \times SA_{6-16} \left(\frac{\text{cm}^2}{\text{day}} \right) \times AF_{6-16} \left(\frac{\text{mg}}{\text{cm}^2} \right) \times 3}{BW_{6-16}(80 \text{ kg})} + \frac{EF_{16-26} \left(\frac{\text{days}}{\text{yr}} \right) \times ED_{16-26}(10 \text{ yr}) \times SA_{16-26} \left(\frac{\text{cm}^2}{\text{day}} \right) \times AF_{16-26} \left(\frac{\text{mg}}{\text{cm}^2} \right) \times 1}{BW_{16-26}(80 \text{ kg})} \right]$$

- inhalation of volatiles and particulates emitted from soil or sediment

$$SL_{\text{rec-sol-inhtce}} \left(\frac{\text{mg}}{\text{kg}} \right) = \frac{TR \times AT_{\text{rec}} \left(\frac{365 \text{ days}}{\text{yr}} \times LT(70 \text{ yrs}) \right)}{IUR \left(\frac{\mu\text{g}}{\text{m}^3} \right)^{-1} \times \left(\frac{1000 \mu\text{g}}{\text{mg}} \right) \times \left(\frac{1}{VF_{\text{ulim}} \left(\frac{\text{m}^3}{\text{kg}} \right)} + \frac{1}{PEF \left(\frac{\text{m}^3}{\text{kg}} \right)} \right) \times \left[\begin{aligned} & \left(EF_{\text{rec}} \left(\frac{\text{days}}{\text{yr}} \right) \times ED_{\text{rec}}(26 \text{ yr}) \times ET_{\text{rec}} \left(\frac{\text{hrs}}{\text{day}} \right) \times \left(\frac{1 \text{ day}}{24 \text{ hrs}} \right) \times CAF_i(0.756) \right) + \\ & \left(EF_{0-2} \left(\frac{\text{days}}{\text{yr}} \right) \times ED_{0-2}(2 \text{ yr}) \times ET_{0-2} \left(\frac{\text{hrs}}{\text{day}} \right) \times \left(\frac{1 \text{ day}}{24 \text{ hrs}} \right) \times MAF_i(0.244) \times 10 \right) + \\ & \left(EF_{2-6} \left(\frac{\text{days}}{\text{yr}} \right) \times ED_{2-6}(4 \text{ yr}) \times ET_{2-6} \left(\frac{\text{hrs}}{\text{day}} \right) \times \left(\frac{1 \text{ day}}{24 \text{ hrs}} \right) \times MAF_i(0.244) \times 3 \right) + \\ & \left(EF_{6-16} \left(\frac{\text{days}}{\text{yr}} \right) \times ED_{6-16}(10 \text{ yr}) \times ET_{6-16} \left(\frac{\text{hrs}}{\text{day}} \right) \times \left(\frac{1 \text{ day}}{24 \text{ hrs}} \right) \times MAF_i(0.244) \times 3 \right) + \\ & \left(EF_{16-26} \left(\frac{\text{days}}{\text{yr}} \right) \times ED_{16-26}(10 \text{ yr}) \times ET_{16-26} \left(\frac{\text{hrs}}{\text{day}} \right) \times \left(\frac{1 \text{ day}}{24 \text{ hrs}} \right) \times MAF_i(0.244) \times 1 \right) \end{aligned} \right]}$$

- Total

$$SL_{\text{rec-sol-tottce}} \left(\frac{\text{mg}}{\text{kg}} \right) = \frac{1}{\frac{1}{SL_{\text{rec-sol-ingtce}}} + \frac{1}{SL_{\text{rec-sol-inhtce}}} + \frac{1}{SL_{\text{rec-sol-dertce}}}}$$

A number of studies have shown that inadvertent ingestion of soil is common among children 6 years old and younger (Calabrese et al. 1989, Davis et al. 1990, Van Wijnen et al. 1990). Therefore, the dose method uses an age-adjusted soil ingestion factor that takes into account the difference in daily soil ingestion rates, body weights, and exposure duration for children from 1 to 6 years old and others from 7 to 26 years old. The equation is presented below. This health-protective approach is chosen to take into account the higher daily rates of soil ingestion in children as well as the longer duration of exposure that is anticipated for a long-term resident. For more on this method, see RAGS Part B (PDF) <<https://semspub.epa.gov/src/document/hq/192>>(68 pp, 721 K).

4.6.1.7 Supporting Equations

- Child

$$ED_{\text{rec-c}}(6 \text{ yr}) = ED_{0-2}(2 \text{ yr}) + ED_{2-6}(4 \text{ yr})$$

$$BW_{\text{rec-c}}(15 \text{ kg}) = \frac{ED_{0-2}(2 \text{ yr}) \times BW_{0-2}(15 \text{ kg}) + ED_{2-6}(4 \text{ yr}) \times BW_{2-6}(15 \text{ kg})}{ED_{0-2}(2 \text{ yr}) + ED_{2-6}(4 \text{ yr})}$$

$$EF_{\text{rec-c}}\left(\frac{\text{days}}{\text{yr}}\right) = \frac{ED_{0-2}(2 \text{ yr}) \times EF_{0-2}\left(\frac{\text{days}}{\text{yr}}\right) + ED_{2-6}(4 \text{ yr}) \times EF_{2-6}\left(\frac{\text{days}}{\text{yr}}\right)}{ED_{0-2}(2 \text{ yr}) + ED_{2-6}(4 \text{ yr})}$$

$$ET_{\text{rec-c}}\left(\frac{\text{hrs}}{\text{day}}\right) = \frac{ED_{0-2}(2 \text{ yr}) \times ET_{0-2}\left(\frac{\text{hrs}}{\text{day}}\right) + ED_{2-6}(4 \text{ yr}) \times ET_{2-6}\left(\frac{\text{hrs}}{\text{day}}\right)}{ED_{0-2}(2 \text{ yr}) + ED_{2-6}(4 \text{ yr})}$$

$$AF_{\text{rec-c}}\left(\frac{\text{mg}}{\text{cm}^2}\right) = \frac{ED_{0-2}(2 \text{ yr}) \times AF_{0-2}\left(\frac{\text{mg}}{\text{cm}^2}\right) + ED_{2-6}(4 \text{ yr}) \times AF_{2-6}\left(\frac{\text{mg}}{\text{cm}^2}\right)}{ED_{0-2}(2 \text{ yr}) + ED_{2-6}(4 \text{ yr})}$$

- Adult

$$ED_{\text{rec-a}}(20 \text{ yr}) = ED_{6-16}(10 \text{ yr}) + ED_{16-26}(10 \text{ yr})$$

$$BW_{\text{rec-a}}(80 \text{ kg}) = \frac{ED_{6-16}(10 \text{ yr}) \times BW_{6-16}(80 \text{ kg}) + ED_{16-26}(10 \text{ yr}) \times BW_{16-26}(80 \text{ kg})}{ED_{6-16}(10 \text{ yr}) + ED_{16-26}(10 \text{ yr})}$$

$$EF_{\text{rec-a}}\left(\frac{\text{days}}{\text{yr}}\right) = \frac{ED_{6-16}(10 \text{ yr}) \times EF_{6-16}\left(\frac{\text{days}}{\text{yr}}\right) + ED_{16-26}(10 \text{ yr}) \times EF_{16-26}\left(\frac{\text{days}}{\text{yr}}\right)}{ED_{6-16}(10 \text{ yr}) + ED_{16-26}(10 \text{ yr})}$$

$$ET_{\text{rec-a}}\left(\frac{\text{hrs}}{\text{day}}\right) = \frac{ED_{6-16}(10 \text{ yr}) \times ET_{6-16}\left(\frac{\text{hrs}}{\text{day}}\right) + ED_{16-26}(10 \text{ yr}) \times ET_{16-26}\left(\frac{\text{hrs}}{\text{day}}\right)}{ED_{6-16}(10 \text{ yr}) + ED_{16-26}(10 \text{ yr})}$$

$$AF_{\text{rec-a}}\left(\frac{\text{mg}}{\text{cm}^2}\right) = \frac{ED_{6-16}(10 \text{ yr}) \times AF_{6-16}\left(\frac{\text{mg}}{\text{cm}^2}\right) + ED_{16-26}(10 \text{ yr}) \times AF_{16-26}\left(\frac{\text{mg}}{\text{cm}^2}\right)}{ED_{6-16}(10 \text{ yr}) + ED_{16-26}(10 \text{ yr})}$$

- Age-adjusted

$$ED_{\text{rec}}(26 \text{ yr}) = ED_{0-2}(2 \text{ yr}) + ED_{2-6}(4 \text{ yr}) + ED_{6-16}(10 \text{ yr}) + ED_{16-26}(10 \text{ yr})$$

$$EF_{\text{rec}}\left(\frac{\text{days}}{\text{yr}}\right) = \frac{\left(ED_{0-2}(2 \text{ yr}) \times EF_{0-2}\left(\frac{\text{days}}{\text{yr}}\right) + ED_{2-6}(4 \text{ yr}) \times EF_{2-6}\left(\frac{\text{days}}{\text{yr}}\right) + \right.}{\left. ED_{6-16}(10 \text{ yr}) \times EF_{6-16}\left(\frac{\text{days}}{\text{yr}}\right) + ED_{16-26}(10 \text{ yr}) \times EF_{16-26}\left(\frac{\text{days}}{\text{yr}}\right) \right)}{ED_{0-2}(2 \text{ yr}) + ED_{2-6}(4 \text{ yr}) + ED_{6-16}(10 \text{ yr}) + ED_{16-26}(10 \text{ yr})}$$

$$ET_{\text{rec}}\left(\frac{\text{hrs}}{\text{day}}\right) = \frac{\left(ED_{0-2}(2 \text{ yr}) \times ET_{0-2}\left(\frac{\text{hrs}}{\text{day}}\right) + ED_{2-6}(4 \text{ yr}) \times ET_{2-6}\left(\frac{\text{hrs}}{\text{day}}\right) + \right.}{\left. ED_{6-16}(10 \text{ yr}) \times ET_{6-16}\left(\frac{\text{hrs}}{\text{day}}\right) + ED_{16-26}(10 \text{ yr}) \times ET_{16-26}\left(\frac{\text{hrs}}{\text{day}}\right) \right)}{ED_{0-2}(2 \text{ yr}) + ED_{2-6}(4 \text{ yr}) + ED_{6-16}(10 \text{ yr}) + ED_{16-26}(10 \text{ yr})}$$

4.6.2 Recreator Surface Water

This receptor is exposed to chemicals that are present in surface water. Ingestion of water and dermal contact with water are appropriate pathways. Dermal contact with surface water is also considered for analytes determined to be within the effective predictive domain as described in Section 4.9.8. Inhalation is not considered due to mixing with outdoor air. There are no default RSLs for this scenario; only site-specific.

The recreator surface water land use is not provided in the Generic Tables but RSLs can be created by using the Calculator.

4.6.2.1 Noncarcinogenic - Child

The recreator surface water land use equation, presented here, contains the following exposure routes:

- incidental ingestion of water

$$SL_{\text{rec-wat-ingnc}} \left(\frac{\mu\text{g}}{\text{L}} \right) = \frac{\text{THQ} \times \text{AT}_{\text{rec-c}} \left(\frac{365 \text{ days}}{\text{yr}} \times \text{ED}_{\text{rec-c}} (6 \text{ yr}) \right) \times \text{BW}_{\text{rec-c}} (15 \text{ kg})}{\left(\frac{1}{\text{RfDo}} \left(\frac{\text{mg}}{\text{kg-day}} \right) \right) \times \left(\frac{\text{mg}}{1000 \mu\text{g}} \right) \times \text{EF}_{\text{rec-c}} \left(\frac{\text{days}}{\text{yr}} \right) \times \text{ED}_{\text{rec-c}} (6 \text{ yr}) \times \text{EV}_{\text{rec-c}} \left(\frac{\text{event}}{\text{day}} \right) \times \text{ET}_{\text{event-rec-c}} \left(\frac{\text{hrs}}{\text{event}} \right) \times \text{IRW}_{\text{rec-c}} \left(\frac{0.12 \text{ L}}{\text{hr}} \right)}$$

- dermal

For Inorganics:

$$SL_{\text{rec-wat-dernc}} \left(\frac{\mu\text{g}}{\text{L}} \right) = \frac{DA_{\text{event}} \left(\frac{\mu\text{g}}{\text{cm}^2 \text{- event}} \right) \times \left(\frac{1000 \text{ cm}^3}{\text{L}} \right)}{K_p \left(\frac{\text{cm}}{\text{hr}} \right) \times ET_{\text{event-rec-c}} \left(\frac{\text{hrs}}{\text{event}} \right)}$$

For Organics:

IF $ET_{\text{event-rec-c}} \left(\frac{\text{hrs}}{\text{event}} \right) \leq t^*$ (hrs), then:

$$SL_{\text{rec-wat-dernc}} \left(\frac{\mu\text{g}}{\text{L}} \right) = \frac{DA_{\text{event}} \left(\frac{\mu\text{g}}{\text{cm}^2 \text{- event}} \right) \times \left(\frac{1000 \text{ cm}^3}{\text{L}} \right)}{2 \times FA \times K_p \left(\frac{\text{cm}}{\text{hr}} \right) \times \sqrt{\frac{6 \times \tau_{\text{event}} \left(\frac{\text{hrs}}{\text{event}} \right) \times ET_{\text{event-rec-c}} \left(\frac{\text{hrs}}{\text{event}} \right)}{\pi}}}$$

or:

IF $ET_{\text{event-rec-c}} \left(\frac{\text{hrs}}{\text{event}} \right) > t^*$ (hrs), then:

$$SL_{\text{rec-wat-dernc}} \left(\frac{\mu\text{g}}{\text{L}} \right) = \frac{DA_{\text{event}} \left(\frac{\mu\text{g}}{\text{cm}^2 \text{- event}} \right) \times \left(\frac{1000 \text{ cm}^3}{\text{L}} \right)}{FA \times K_p \left(\frac{\text{cm}}{\text{hr}} \right) \times \left[\frac{ET_{\text{event-rec-c}} \left(\frac{\text{hrs}}{\text{event}} \right)}{1 + B} + 2 \times \tau_{\text{event}} \left(\frac{\text{hrs}}{\text{event}} \right) \times \left(\frac{1 + 3B + 3B^2}{(1 + B)^2} \right) \right]}$$

where:

$$DA_{\text{event}} \left(\frac{\mu\text{g}}{\text{cm}^2 \text{- event}} \right) = \frac{\text{THQ} \times \text{AT}_{\text{rec-c}} \left(\frac{365 \text{ days}}{\text{yr}} \times \text{ED}_{\text{rec-c}} (6 \text{ yr}) \right) \times \text{BW}_{\text{rec-c}} (15 \text{ kg})}{\left(\frac{1}{\text{RfD}_0 \left(\frac{\text{mg}}{\text{kg-day}} \right) \times \text{GIABS}} \right) \times \left(\frac{\text{mg}}{1000 \mu\text{g}} \right) \times \text{EF}_{\text{rec-c}} \left(\frac{\text{days}}{\text{yr}} \right) \times \text{ED}_{\text{rec-c}} (6 \text{ yr}) \times \text{EV}_{\text{rec-c}} \left(\frac{\text{event}}{\text{day}} \right) \times \text{SA}_{\text{rec-c}} (6,365 \text{ cm}^2)}$$

- Total

$$SL_{\text{rec-wat-totnc}} \left(\frac{\mu\text{g}}{\text{L}} \right) = \frac{1}{\frac{1}{SL_{\text{rec-wat-ingnc}}} + \frac{1}{SL_{\text{rec-wat-dernc}}}}$$

4.6.2.2 Noncarcinogenic - Adult

The recreator surface water land use equation, presented here, contains the following exposure routes:

- incidental ingestion of water

$$SL_{\text{rec-wat-ingna}} \left(\frac{\mu\text{g}}{\text{L}} \right) = \frac{\text{THQ} \times \text{AT}_{\text{rec-a}} \left(\frac{365 \text{ days}}{\text{yr}} \times \text{ED}_{\text{rec}} (26 \text{ yr}) \right) \times \text{BW}_{\text{rec-a}} (80 \text{ kg})}{\left(\frac{1}{\text{RfD}_0 \left(\frac{\text{mg}}{\text{kg-day}} \right)} \right) \times \left(\frac{\text{mg}}{1000 \mu\text{g}} \right) \times \text{EF}_{\text{rec-a}} \left(\frac{\text{days}}{\text{yr}} \right) \times \text{ED}_{\text{rec}} (26 \text{ yr}) \times \text{EV}_{\text{rec-a}} \left(\frac{\text{event}}{\text{day}} \right) \times \text{ET}_{\text{event-rec-a}} \left(\frac{\text{hrs}}{\text{event}} \right) \times \text{IRW}_{\text{rec-a}} \left(\frac{0.11 \text{ L}}{\text{hr}} \right)}$$

- dermal

For Inorganics:

$$SL_{\text{rec-wat-derma}} \left(\frac{\mu\text{g}}{\text{L}} \right) = \frac{DA_{\text{event}} \left(\frac{\mu\text{g}}{\text{cm}^2 \cdot \text{event}} \right) \times \left(\frac{1000 \text{ cm}^3}{\text{L}} \right)}{K_p \left(\frac{\text{cm}}{\text{hr}} \right) \times ET_{\text{event-rec-a}} \left(\frac{\text{hrs}}{\text{event}} \right)}$$

For Organics:

IF $ET_{\text{event-rec-a}} \left(\frac{\text{hrs}}{\text{event}} \right) \leq t^*$ (hrs), then:

$$SL_{\text{rec-wat-derma}} \left(\frac{\mu\text{g}}{\text{L}} \right) = \frac{DA_{\text{event}} \left(\frac{\mu\text{g}}{\text{cm}^2 \cdot \text{event}} \right) \times \left(\frac{1000 \text{ cm}^3}{\text{L}} \right)}{2 \times FA \times K_p \left(\frac{\text{cm}}{\text{hr}} \right) \times \sqrt{\frac{6 \times \tau_{\text{event}} \left(\frac{\text{hrs}}{\text{event}} \right) \times ET_{\text{event-rec-a}} \left(\frac{\text{hrs}}{\text{event}} \right)}{\pi}}}$$

or:

IF $ET_{\text{event-rec-a}} \left(\frac{\text{hrs}}{\text{event}} \right) > t^*$ (hrs), then:

$$SL_{\text{rec-wat-derma}} \left(\frac{\mu\text{g}}{\text{L}} \right) = \frac{DA_{\text{event}} \left(\frac{\mu\text{g}}{\text{cm}^2 \cdot \text{event}} \right) \times \left(\frac{1000 \text{ cm}^3}{\text{L}} \right)}{FA \times K_p \left(\frac{\text{cm}}{\text{hr}} \right) \times \left[\frac{ET_{\text{event-rec-a}} \left(\frac{\text{hrs}}{\text{event}} \right)}{1 + B} + 2 \times \tau_{\text{event}} \left(\frac{\text{hrs}}{\text{event}} \right) \times \left(\frac{1 + 3B + 3B^2}{(1 + B)^2} \right) \right]}$$

where:

$$DA_{\text{event}} \left(\frac{\mu\text{g}}{\text{cm}^2 \cdot \text{event}} \right) = \frac{THQ \times AT_{\text{rec-a}} \left(\frac{365 \text{ days}}{\text{yr}} \times ED_{\text{rec}}(26 \text{ yr}) \right) \times BW_{\text{rec-a}}(80 \text{ kg})}{\left(\frac{1}{RfD_o \left(\frac{\text{mg}}{\text{kg} \cdot \text{day}} \right) \times GIABS \right) \times \left(\frac{\text{mg}}{1000 \mu\text{g}} \right) \times EF_{\text{rec-a}} \left(\frac{\text{days}}{\text{yr}} \right) \times ED_{\text{rec}}(26 \text{ yr}) \times EV_{\text{rec-a}} \left(\frac{\text{event}}{\text{day}} \right) \times SA_{\text{rec-a}}(19,652 \text{ cm}^2)}$$

- Total

$$SL_{\text{rec-wat-totna}} \left(\frac{\mu\text{g}}{\text{L}} \right) = \frac{1}{\frac{1}{SL_{\text{rec-wat-ingna}}} + \frac{1}{SL_{\text{rec-wat-derma}}}}$$

4.6.2.3 Carcinogenic

The recreator surface water land use equation, presented here, contains the following exposure routes:

- incidental ingestion of water

$$SL_{\text{rec-wat-ingc}} \left(\frac{\mu\text{g}}{\text{L}} \right) = \frac{\text{TR} \times \text{AT}_{\text{rec}} \left(\frac{365 \text{ days}}{\text{yr}} \times \text{LT}(70 \text{ yrs}) \right)}{\text{CSF}_o \left(\frac{\text{mg}}{\text{kg-day}} \right)^{-1} \times \left(\frac{\text{mg}}{1000 \mu\text{g}} \right) \times \text{IFW}_{\text{rec-adj}} \left(\frac{\text{L}}{\text{kg}} \right)}$$

where:

$$\text{IFW}_{\text{rec-adj}} \left(\frac{\text{L}}{\text{kg}} \right) = \left[\frac{\text{EF}_{\text{rec-c}} \left(\frac{\text{days}}{\text{yr}} \right) \times \text{ED}_{\text{rec-c}}(6 \text{ yr}) \times \text{EV}_{\text{rec-c}} \left(\frac{\text{event}}{\text{day}} \right) \times \text{ET}_{\text{event-rec-c}} \left(\frac{\text{hrs}}{\text{event}} \right) \times \text{IRW}_{\text{rec-c}} \left(\frac{0.12 \text{ L}}{\text{hr}} \right)}{\text{BW}_{\text{rec-c}}(15 \text{ kg})} + \frac{\text{EF}_{\text{rec-a}} \left(\frac{\text{days}}{\text{yr}} \right) \times \text{ED}_{\text{rec-a}}(20 \text{ yr}) \times \text{EV}_{\text{rec-a}} \left(\frac{\text{event}}{\text{day}} \right) \times \text{ET}_{\text{event-rec-a}} \left(\frac{\text{hrs}}{\text{event}} \right) \times \text{IRW}_{\text{rec-a}} \left(\frac{0.11 \text{ L}}{\text{hr}} \right)}{\text{BW}_{\text{rec-a}}(80 \text{ kg})} \right]$$

- dermal

For Inorganics:

$$SL_{\text{rec-wat-derc}} \left(\frac{\mu\text{g}}{\text{L}} \right) = \frac{DA_{\text{event}} \left(\frac{\mu\text{g}}{\text{cm}^2 \text{- event}} \right) \times \left(\frac{1000 \text{ cm}^3}{\text{L}} \right)}{K_p \left(\frac{\text{cm}}{\text{hr}} \right) \times ET_{\text{event-rec-adj}} \left(\frac{\text{hrs}}{\text{event}} \right)}$$

For Organics:

IF $ET_{\text{event-rec-adj}} \left(\frac{\text{hrs}}{\text{event}} \right) \leq t^*$ (hrs), then:

$$SL_{\text{rec-wat-derc}} \left(\frac{\mu\text{g}}{\text{L}} \right) = \frac{DA_{\text{event}} \left(\frac{\mu\text{g}}{\text{cm}^2 \text{- event}} \right) \times \left(\frac{1000 \text{ cm}^3}{\text{L}} \right)}{2 \times FA \times K_p \left(\frac{\text{cm}}{\text{hr}} \right) \times \sqrt{\frac{6 \times \tau_{\text{event}} \left(\frac{\text{hrs}}{\text{event}} \right) \times ET_{\text{event-rec-adj}} \left(\frac{\text{hrs}}{\text{event}} \right)}{\pi}}}$$

or:

IF $ET_{\text{event-rec-adj}} \left(\frac{\text{hrs}}{\text{event}} \right) > t^*$ (hrs), then:

$$SL_{\text{rec-wat-derc}} \left(\frac{\mu\text{g}}{\text{L}} \right) = \frac{DA_{\text{event}} \left(\frac{\mu\text{g}}{\text{cm}^2 \text{- event}} \right) \times \left(\frac{1000 \text{ cm}^3}{\text{L}} \right)}{FA \times K_p \left(\frac{\text{cm}}{\text{hr}} \right) \times \left[\frac{ET_{\text{event-rec-adj}} \left(\frac{\text{hrs}}{\text{event}} \right)}{1 + B} + 2 \times \tau_{\text{event}} \left(\frac{\text{hrs}}{\text{event}} \right) \times \left(\frac{1 + 3B + 3B^2}{(1 + B)^2} \right) \right]}$$

where:

$$ET_{\text{event-rec-adj}} \left(\frac{\text{hrs}}{\text{event}} \right) = \left(\frac{\left(ED_{\text{rec-c}}(6 \text{ yr}) \times ET_{\text{event-rec-c}} \left(\frac{\text{hrs}}{\text{event}} \right) \right) + \left(ED_{\text{rec-a}}(20 \text{ yr}) \times ET_{\text{event-rec-a}} \left(\frac{\text{hrs}}{\text{event}} \right) \right)}{ED_{\text{rec}}(26 \text{ yr})} \right)$$

and:

$$DA_{\text{event}} \left(\frac{\mu\text{g}}{\text{cm}^2 \text{- event}} \right) = \frac{TR \times AT_{\text{rec}} \left(\frac{365 \text{ days}}{\text{yr}} \times LT(70 \text{ yrs}) \right)}{\left(\frac{CSF_o \left(\frac{\text{mg}}{\text{kg-day}} \right)^{-1}}{GIABS} \right) \times \left(\frac{\text{mg}}{1000 \mu\text{g}} \right) \times DFW_{\text{rec-adj}} \left(\frac{\text{cm}^2 \text{- event}}{\text{kg}} \right)}$$

where:

$$DFW_{\text{rec-adj}} \left(\frac{\text{cm}^2 \text{- event}}{\text{kg}} \right) = \left(\frac{EF_{\text{rec-c}} \left(\frac{\text{days}}{\text{yr}} \right) \times ED_{\text{rec-c}}(6 \text{ yr}) \times EV_{\text{rec-c}} \left(\frac{\text{event}}{\text{day}} \right) \times SA_{\text{rec-c}}(6,365 \text{ cm}^2)}{BW_{\text{rec-c}}(15 \text{ kg})} + \frac{EF_{\text{rec-a}} \left(\frac{\text{days}}{\text{yr}} \right) \times ED_{\text{rec-a}}(20 \text{ yr}) \times EV_{\text{rec-a}} \left(\frac{\text{event}}{\text{day}} \right) \times SA_{\text{rec-a}}(19,652 \text{ cm}^2)}{BW_{\text{rec-a}}(80 \text{ kg})} \right)$$

- Total

$$SL_{\text{rec-wat-totc}} \left(\frac{\mu\text{g}}{\text{L}} \right) = \frac{1}{\frac{1}{SL_{\text{rec-wat-ingc}}} + \frac{1}{SL_{\text{rec-wat-derc}}}}$$

4.6.2.4 Mutagenic

The recreator surface water land use equation, presented here, contains the following exposure routes:

- incidental ingestion of water

$$SL_{\text{rec-wat-ingmu}} \left(\frac{\mu\text{g}}{\text{L}} \right) = \frac{\text{TR} \times \text{AT}_{\text{rec}} \left(\frac{365 \text{ days}}{\text{yr}} \times \text{LT} (70 \text{ yrs}) \right)}{\text{CSF}_o \left(\frac{\text{mg}}{\text{kg-day}} \right)^{-1} \times \left(\frac{\text{mg}}{1000 \mu\text{g}} \right) \times \text{IFWM}_{\text{rec-adj}} \left(\frac{\text{L}}{\text{kg}} \right)}$$

where:

$$\text{IFWM}_{\text{rec-adj}} \left(\frac{\text{L}}{\text{kg}} \right) = \left[\begin{array}{l} \frac{\text{EF}_{0-2} \left(\frac{\text{days}}{\text{yr}} \right) \times \text{ED}_{0-2} (2 \text{ yr}) \times \text{EV}_{0-2} \left(\frac{\text{event}}{\text{day}} \right) \times \text{ET}_{\text{event-(0-2)}} \left(\frac{\text{hrs}}{\text{event}} \right) \times \text{IRW}_{0-2} \left(\frac{0.12 \text{ L}}{\text{hr}} \right) \times 10}{\text{BW}_{0-2} (15 \text{ kg})} + \\ \frac{\text{EF}_{2-6} \left(\frac{\text{days}}{\text{yr}} \right) \times \text{ED}_{2-6} (4 \text{ yr}) \times \text{EV}_{2-6} \left(\frac{\text{event}}{\text{day}} \right) \times \text{ET}_{\text{event-(2-6)}} \left(\frac{\text{hrs}}{\text{event}} \right) \times \text{IRW}_{2-6} \left(\frac{0.12 \text{ L}}{\text{hr}} \right) \times 3}{\text{BW}_{2-6} (15 \text{ kg})} + \\ \frac{\text{EF}_{6-16} \left(\frac{\text{days}}{\text{yr}} \right) \times \text{ED}_{6-16} (10 \text{ yr}) \times \text{EV}_{6-16} \left(\frac{\text{event}}{\text{day}} \right) \times \text{ET}_{\text{event-(6-16)}} \left(\frac{\text{hrs}}{\text{event}} \right) \times \text{IRW}_{6-16} \left(\frac{0.124 \text{ L}}{\text{hr}} \right) \times 3}{\text{BW}_{6-16} (80 \text{ kg})} + \\ \frac{\text{EF}_{16-26} \left(\frac{\text{days}}{\text{yr}} \right) \times \text{ED}_{16-26} (10 \text{ yr}) \times \text{EV}_{16-26} \left(\frac{\text{event}}{\text{day}} \right) \times \text{ET}_{\text{event-(16-26)}} \left(\frac{\text{hrs}}{\text{event}} \right) \times \text{IRW}_{16-26} \left(\frac{0.098 \text{ L}}{\text{hr}} \right) \times 1}{\text{BW}_{16-26} (80 \text{ kg})} \end{array} \right]$$

- dermal

For Inorganics:

$$SL_{\text{rec-wat-dermu}} \left(\frac{\mu\text{g}}{\text{L}} \right) = \frac{DA_{\text{event}} \left(\frac{\mu\text{g}}{\text{cm}^2 \cdot \text{event}} \right) \times \left(\frac{1000 \text{ cm}^3}{\text{L}} \right)}{K_p \left(\frac{\text{cm}}{\text{hr}} \right) \times ET_{\text{event-rec-madj}} \left(\frac{\text{hrs}}{\text{event}} \right)}$$

For Organics:

IF $ET_{\text{event-rec-madj}} \left(\frac{\text{hrs}}{\text{event}} \right) \leq t^*$ (hrs), then:

$$SL_{\text{rec-wat-dermu}} \left(\frac{\mu\text{g}}{\text{L}} \right) = \frac{DA_{\text{event}} \left(\frac{\mu\text{g}}{\text{cm}^2 \cdot \text{event}} \right) \times \left(\frac{1000 \text{ cm}^3}{\text{L}} \right)}{2 \times FA \times K_p \left(\frac{\text{cm}}{\text{hr}} \right) \times \sqrt{\frac{6 \times \tau_{\text{event}} \left(\frac{\text{hrs}}{\text{event}} \right) \times ET_{\text{event-rec-madj}} \left(\frac{\text{hrs}}{\text{event}} \right)}{\pi}}}$$

or:

IF $ET_{\text{event-rec-madj}} \left(\frac{\text{hrs}}{\text{event}} \right) > t^*$ (hrs), then:

$$SL_{\text{rec-wat-dermu}} \left(\frac{\mu\text{g}}{\text{L}} \right) = \frac{DA_{\text{event}} \left(\frac{\mu\text{g}}{\text{cm}^2 \cdot \text{event}} \right) \times \left(\frac{1000 \text{ cm}^3}{\text{L}} \right)}{FA \times K_p \left(\frac{\text{cm}}{\text{hr}} \right) \times \left[\frac{ET_{\text{event-rec-madj}} \left(\frac{\text{hrs}}{\text{event}} \right)}{1 + B} + 2 \times \tau_{\text{event}} \left(\frac{\text{hrs}}{\text{event}} \right) \times \left(\frac{1 + 3B + 3B^2}{(1 + B)^2} \right) \right]}$$

where:

$$ET_{\text{event-rec-madj}} \left(\frac{\text{hrs}}{\text{event}} \right) = \frac{\left(ED_{0-2} (2 \text{ yr}) \times ET_{\text{event-(0-2)}} \left(\frac{\text{hrs}}{\text{event}} \right) \right) + \left(ED_{2-6} (4 \text{ yr}) \times ET_{\text{event-(2-6)}} \left(\frac{\text{hrs}}{\text{event}} \right) \right) + \left(ED_{6-16} (10 \text{ yr}) \times ET_{\text{event-(6-16)}} \left(\frac{\text{hrs}}{\text{event}} \right) \right) + \left(ED_{16-26} (10 \text{ yr}) \times ET_{\text{event-(16-26)}} \left(\frac{\text{hrs}}{\text{event}} \right) \right)}{ED_{0-2} (2 \text{ yr}) + ED_{2-6} (4 \text{ yr}) + ED_{6-16} (10 \text{ yr}) + ED_{16-26} (10 \text{ yr})}$$

and:

$$DA_{\text{event}} \left(\frac{\mu\text{g}}{\text{cm}^2 \cdot \text{event}} \right) = \frac{TR \times AT_{\text{rec}} \left(\frac{365 \text{ days}}{\text{yr}} \times LT (70 \text{ yrs}) \right)}{\left(\frac{CSFo \left(\frac{\text{mg}}{\text{kg} \cdot \text{day}} \right)^{-1}}{GIABS} \right) \times \left(\frac{\text{mg}}{1000 \mu\text{g}} \right) \times DFWM_{\text{rec-adj}} \left(\frac{\text{cm}^2 \cdot \text{event}}{\text{kg}} \right)}$$

where:

$$DFWM_{\text{rec-adj}} \left(\frac{\text{cm}^2 \cdot \text{event}}{\text{kg}} \right) = \left(\frac{EF_{0-2} \left(\frac{\text{days}}{\text{yr}} \right) \times ED_{0-2} (2 \text{ yr}) \times EV_{0-2} \left(\frac{\text{event}}{\text{day}} \right) \times SA_{0-2} (6,365 \text{ cm}^2) \times 10}{BW_{0-2} (15 \text{ kg})} + \frac{EF_{2-6} \left(\frac{\text{days}}{\text{yr}} \right) \times ED_{2-6} (4 \text{ yr}) \times EV_{2-6} \left(\frac{\text{event}}{\text{day}} \right) \times SA_{2-6} (6,365 \text{ cm}^2) \times 3}{BW_{2-6} (15 \text{ kg})} + \frac{EF_{6-16} \left(\frac{\text{days}}{\text{yr}} \right) \times ED_{6-16} (10 \text{ yr}) \times EV_{6-16} \left(\frac{\text{event}}{\text{day}} \right) \times SA_{6-16} (19,652 \text{ cm}^2) \times 3}{BW_{6-16} (80 \text{ kg})} + \frac{EF_{16-26} \left(\frac{\text{days}}{\text{yr}} \right) \times ED_{16-26} (10 \text{ yr}) \times EV_{16-26} \left(\frac{\text{event}}{\text{day}} \right) \times SA_{16-26} (19,652 \text{ cm}^2) \times 1}{BW_{16-26} (80 \text{ kg})} \right)$$

- Total

$$SL_{\text{rec-wat-totmu}} \left(\frac{\mu\text{g}}{\text{L}} \right) = \frac{1}{\frac{1}{SL_{\text{rec-wat-ingmu}}} + \frac{1}{SL_{\text{rec-wat-dermu}}}}$$

4.6.2.5 Vinyl Chloride - Carcinogenic

The recreator surface water land use equation, presented here, contains the following exposure routes:

- incidental ingestion of water

$$SL_{\text{rec-wat-ingvc}} \left(\frac{\mu\text{g}}{\text{L}} \right) = \frac{\text{TR}}{\left(\frac{\left(\text{CSF}_o \left(\frac{\text{mg}}{\text{kg-day}} \right)^{-1} \times \left(\frac{\text{mg}}{1000 \mu\text{g}} \right) \times \text{IFW}_{\text{rec-adj}} \left(\frac{\text{L}}{\text{kg}} \right) \right)}{\text{AT}_{\text{rec}} \left(\frac{365 \text{ days}}{\text{yr}} \times \text{LT}(70 \text{ yrs}) \right)} + \frac{\left(\text{CSF}_o \left(\frac{\text{mg}}{\text{kg-day}} \right)^{-1} \times \left(\frac{\text{mg}}{1000 \mu\text{g}} \right) \times \text{EV}_{\text{rec-c}} \left(\frac{\text{event}}{\text{day}} \right) \times \text{ET}_{\text{event-rec-c}} \left(\frac{\text{hrs}}{\text{event}} \right) \times \text{IRW}_{\text{rec-c}} \left(\frac{0.12 \text{ L}}{\text{hr}} \right)}{\text{BW}_{\text{rec-c}} (15 \text{ kg})} \right)}$$

where:

$$\text{IFW}_{\text{rec-adj}} \left(\frac{\text{L}}{\text{kg}} \right) = \frac{\left[\frac{\text{EF}_{\text{rec-c}} \left(\frac{\text{days}}{\text{yr}} \right) \times \text{ED}_{\text{rec-c}} (6 \text{ yr}) \times \text{EV}_{\text{rec-c}} \left(\frac{\text{event}}{\text{day}} \right) \times \text{ET}_{\text{event-rec-c}} \left(\frac{\text{hrs}}{\text{event}} \right) \times \text{IRW}_{\text{rec-c}} \left(\frac{0.12 \text{ L}}{\text{hr}} \right)}{\text{BW}_{\text{rec-c}} (15 \text{ kg})} + \frac{\text{EF}_{\text{rec-a}} \left(\frac{\text{days}}{\text{yr}} \right) \times \text{ED}_{\text{rec-a}} (20 \text{ yr}) \times \text{EV}_{\text{rec-a}} \left(\frac{\text{event}}{\text{day}} \right) \times \text{ET}_{\text{event-rec-a}} \left(\frac{\text{hrs}}{\text{event}} \right) \times \text{IRW}_{\text{rec-a}} \left(\frac{0.11 \text{ L}}{\text{hr}} \right)}{\text{BW}_{\text{rec-a}} (80 \text{ kg})} \right]}$$

- dermal

IF $ET_{\text{event-rec-adj}} \left(\frac{\text{hrs}}{\text{event}} \right) \leq t^*$ (hrs), then:

$$SL_{\text{rec-wat-dervc}} \left(\frac{\mu\text{g}}{\text{L}} \right) = \frac{DA_{\text{vc-event}} \left(\frac{\mu\text{g}}{\text{cm}^2\text{-event}} \right) \times \left(\frac{1000 \text{ cm}^3}{\text{L}} \right)}{2 \times FA \times K_p \left(\frac{\text{cm}}{\text{hr}} \right) \times \sqrt{\frac{6 \times \tau_{\text{event}} \left(\frac{\text{hrs}}{\text{event}} \right) \times ET_{\text{event-rec-adj}} \left(\frac{\text{hrs}}{\text{event}} \right)}{\pi}}}$$

or:

IF $ET_{\text{event-rec-adj}} \left(\frac{\text{hrs}}{\text{event}} \right) > t^*$ (hrs), then:

$$SL_{\text{rec-wat-dervc}} \left(\frac{\mu\text{g}}{\text{L}} \right) = \frac{DA_{\text{vc-event}} \left(\frac{\mu\text{g}}{\text{cm}^2\text{-event}} \right) \times \left(\frac{1000 \text{ cm}^3}{\text{L}} \right)}{FA \times K_p \left(\frac{\text{cm}}{\text{hr}} \right) \times \left[\frac{ET_{\text{event-rec-adj}} \left(\frac{\text{hrs}}{\text{event}} \right)}{1 + B} + 2 \times \tau_{\text{event}} \left(\frac{\text{hrs}}{\text{event}} \right) \times \left(\frac{1 + 3B + 3B^2}{(1 + B)^2} \right) \right]}$$

where:

$$ET_{\text{event-rec-adj}} \left(\frac{\text{hrs}}{\text{event}} \right) = \left(\frac{ED_{\text{rec-c}} (6 \text{ yr}) \times ET_{\text{event-rec-c}} \left(\frac{\text{hrs}}{\text{event}} \right)}{ED_{\text{rec}} (26 \text{ yr})} \right) + \left(\frac{ED_{\text{rec-a}} (20 \text{ yr}) \times ET_{\text{event-rec-a}} \left(\frac{\text{hrs}}{\text{event}} \right)}{ED_{\text{rec}} (26 \text{ yr})} \right)$$

and:

$$DA_{\text{vc-event}} \left(\frac{\mu\text{g}}{\text{cm}^2\text{-event}} \right) = \frac{TR}{\left(\frac{CSF_o \left(\frac{\text{mg}}{\text{kg}\text{-day}} \right)^{-1}}{GIABS} \right) \times \left(\frac{\text{mg}}{1000 \mu\text{g}} \right) \times \left[\frac{DFW_{\text{rec-adj}} \left(\frac{\text{cm}^2\text{-event}}{\text{kg}} \right)}{AT_{\text{rec}} \left(\frac{365 \text{ days}}{\text{yr}} \times LT (70 \text{ yrs}) \right)} + \left(\frac{EV_{\text{rec-c}} \left(\frac{\text{event}}{\text{day}} \right) \times SA_{\text{rec-c}} \left(6,365 \text{ cm}^2 \right)}{BW_{\text{rec-c}} (15 \text{ kg})} \right) \right]}$$

where:

$$DFW_{\text{rec-adj}} \left(\frac{\text{cm}^2\text{-event}}{\text{kg}} \right) = \left(\frac{EF_{\text{rec-c}} \left(\frac{\text{days}}{\text{yr}} \right) \times ED_{\text{rec-c}} (6 \text{ yr}) \times EV_{\text{rec-c}} \left(\frac{\text{event}}{\text{day}} \right) \times SA_{\text{rec-c}} \left(6,365 \text{ cm}^2 \right)}{BW_{\text{rec-c}} (15 \text{ kg})} + \frac{EF_{\text{rec-a}} \left(\frac{\text{days}}{\text{yr}} \right) \times ED_{\text{rec-a}} (20 \text{ yr}) \times EV_{\text{rec-a}} \left(\frac{\text{event}}{\text{day}} \right) \times SA_{\text{rec-a}} \left(19,652 \text{ cm}^2 \right)}{BW_{\text{rec-a}} (80 \text{ kg})} \right)$$

- Total

$$SL_{\text{rec-wat-totvc}} \left(\frac{\mu\text{g}}{\text{L}} \right) = \frac{1}{\frac{1}{SL_{\text{rec-wat-ingvc}}} + \frac{1}{SL_{\text{rec-wat-dervc}}}}$$

4.6.2.6 Trichloroethylene – Carcinogenic and Mutagenic

The recreator surface water land use equation, presented here, contains the following exposure routes:

- incidental ingestion of water

$$SL_{\text{rec-wat-ingtce}} \left(\frac{\mu\text{g}}{\text{L}} \right) = \frac{TR \times AT_{\text{rec}} \left(\frac{365 \text{ days}}{\text{yr}} \times LT(70 \text{ yrs}) \right)}{CSF_o \left(\frac{\text{mg}}{\text{kg-day}} \right)^{-1} \times \left(\frac{\text{mg}}{1000 \mu\text{g}} \right) \times \left(\left(CAF_o(0.804) \times IFW_{\text{rec-adj}} \left(\frac{\text{L}}{\text{kg}} \right) \right) + \left(MAF_o(0.202) \times IFWM_{\text{rec-adj}} \left(\frac{\text{L}}{\text{kg}} \right) \right) \right)}$$

where:

$$IFW_{\text{rec-adj}} \left(\frac{\text{L}}{\text{kg}} \right) = \left[\frac{EF_{\text{rec-c}} \left(\frac{\text{days}}{\text{yr}} \right) \times ED_{\text{rec-c}}(6 \text{ yr}) \times EV_{\text{rec-c}} \left(\frac{\text{event}}{\text{day}} \right) \times ET_{\text{event-rec-c}} \left(\frac{\text{hrs}}{\text{event}} \right) \times IRW_{\text{rec-c}} \left(\frac{0.12 \text{ L}}{\text{hr}} \right)}{BW_{\text{rec-c}}(15 \text{ kg})} + \frac{EF_{\text{rec-a}} \left(\frac{\text{days}}{\text{yr}} \right) \times ED_{\text{rec-a}}(20 \text{ yr}) \times EV_{\text{rec-a}} \left(\frac{\text{event}}{\text{day}} \right) \times ET_{\text{event-rec-a}} \left(\frac{\text{hrs}}{\text{event}} \right) \times IRW_{\text{rec-a}} \left(\frac{0.11 \text{ L}}{\text{hr}} \right)}{BW_{\text{rec-a}}(80 \text{ kg})} \right]$$

and:

$$IFWM_{\text{rec-adj}} \left(\frac{\text{L}}{\text{kg}} \right) = \left[\frac{EF_{0-2} \left(\frac{\text{days}}{\text{yr}} \right) \times ED_{0-2}(2 \text{ yr}) \times EV_{0-2} \left(\frac{\text{event}}{\text{day}} \right) \times ET_{\text{event-(0-2)}} \left(\frac{\text{hrs}}{\text{event}} \right) \times IRW_{0-2} \left(\frac{0.12 \text{ L}}{\text{hr}} \right) \times 10}{BW_{0-2}(15 \text{ kg})} + \frac{EF_{2-6} \left(\frac{\text{days}}{\text{yr}} \right) \times ED_{2-6}(4 \text{ yr}) \times EV_{2-6} \left(\frac{\text{event}}{\text{day}} \right) \times ET_{\text{event-(2-6)}} \left(\frac{\text{hrs}}{\text{event}} \right) \times IRW_{2-6} \left(\frac{0.12 \text{ L}}{\text{hr}} \right) \times 3}{BW_{2-6}(15 \text{ kg})} + \frac{EF_{6-16} \left(\frac{\text{days}}{\text{yr}} \right) \times ED_{6-16}(10 \text{ yr}) \times EV_{6-16} \left(\frac{\text{event}}{\text{day}} \right) \times ET_{\text{event-(6-16)}} \left(\frac{\text{hrs}}{\text{event}} \right) \times IRW_{6-16} \left(\frac{0.124 \text{ L}}{\text{hr}} \right) \times 3}{BW_{6-16}(80 \text{ kg})} + \frac{EF_{16-26} \left(\frac{\text{days}}{\text{yr}} \right) \times ED_{16-26}(10 \text{ yr}) \times EV_{16-26} \left(\frac{\text{event}}{\text{day}} \right) \times ET_{\text{event-(16-26)}} \left(\frac{\text{hrs}}{\text{event}} \right) \times IRW_{16-26} \left(\frac{0.098 \text{ L}}{\text{hr}} \right) \times 1}{BW_{16-26}(80 \text{ kg})} \right]$$

- dermal

IF $ET_{\text{event-rec-madj}} \left(\frac{\text{hrs}}{\text{event}} \right) \leq t^* \text{ (hrs)}$, then:

$$SL_{\text{rec-wat-dertce}} \left(\frac{\mu\text{g}}{\text{L}} \right) = \frac{DA_{\text{tce-event}} \left(\frac{\mu\text{g}}{\text{cm}^2\text{-event}} \right) \times \left(\frac{1000 \text{ cm}^3}{\text{L}} \right)}{2 \times FA \times K_p \left(\frac{\text{cm}}{\text{hr}} \right) \times \sqrt{\frac{6 \times \tau_{\text{event}} \left(\frac{\text{hrs}}{\text{event}} \right) \times ET_{\text{event-rec-madj}} \left(\frac{\text{hrs}}{\text{event}} \right)}{\pi}}}$$

or:

IF $ET_{\text{event-rec-madj}} \left(\frac{\text{hrs}}{\text{event}} \right) > t^* \text{ (hrs)}$, then:

$$SL_{\text{rec-wat-dertce}} \left(\frac{\mu\text{g}}{\text{L}} \right) = \frac{DA_{\text{tce-event}} \left(\frac{\mu\text{g}}{\text{cm}^2\text{-event}} \right) \times \left(\frac{1000 \text{ cm}^3}{\text{L}} \right)}{FA \times K_p \left(\frac{\text{cm}}{\text{hr}} \right) \times \left[\frac{ET_{\text{event-rec-madj}} \left(\frac{\text{hrs}}{\text{event}} \right)}{1 + B} + 2 \times \tau_{\text{event}} \left(\frac{\text{hrs}}{\text{event}} \right) \times \left(\frac{1 + 3B + 3B^2}{(1 + B)^2} \right) \right]}$$

where:

$$ET_{\text{event-rec-madj}} \left(\frac{\text{hrs}}{\text{event}} \right) = \frac{\left(ED_{0-2} (2 \text{ yr}) \times ET_{\text{event-(0-2)}} \left(\frac{\text{hrs}}{\text{event}} \right) \right) + \left(ED_{2-6} (4 \text{ yr}) \times ET_{\text{event-(2-6)}} \left(\frac{\text{hrs}}{\text{event}} \right) \right) + \left(ED_{6-16} (10 \text{ yr}) \times ET_{\text{event-(6-16)}} \left(\frac{\text{hrs}}{\text{event}} \right) \right) + \left(ED_{16-26} (10 \text{ yr}) \times ET_{\text{event-(16-26)}} \left(\frac{\text{hrs}}{\text{event}} \right) \right)}{ED_{0-2} (2 \text{ yr}) + ED_{2-6} (4 \text{ yr}) + ED_{6-16} (10 \text{ yr}) + ED_{16-26} (10 \text{ yr})}$$

and:

$$DA_{\text{tce-event}} \left(\frac{\mu\text{g}}{\text{cm}^2\text{-event}} \right) = \frac{TR \times AT_{\text{rec}} \left(\frac{365 \text{ days}}{\text{yr}} \times LT (70 \text{ yrs}) \right)}{\left(\frac{CSF_o \left(\frac{\text{mg}}{\text{kg-day}} \right)^{-1}}{GIABS} \right) \times \left(\frac{\text{mg}}{1000 \mu\text{g}} \right) \times \left[\left(CAF_o (0.804) \times DFW_{\text{rec-adj}} \left(\frac{\text{cm}^2\text{-event}}{\text{kg}} \right) \right) + \left(MAF_o (0.202) \times DFWM_{\text{rec-adj}} \left(\frac{\text{cm}^2\text{-event}}{\text{kg}} \right) \right) \right]}$$

where:

$$DFW_{\text{rec-adj}} \left(\frac{\text{cm}^2\text{-event}}{\text{kg}} \right) = \frac{\left(\frac{EF_{\text{rec-c}} \left(\frac{\text{days}}{\text{yr}} \right) \times ED_{\text{rec-c}} (6 \text{ yr}) \times EV_{\text{rec-c}} \left(\frac{\text{event}}{\text{day}} \right) \times SA_{\text{rec-c}} (6,365 \text{ cm}^2) \right)}{BW_{\text{rec-c}} (15 \text{ kg})} + \frac{\left(\frac{EF_{\text{rec-a}} \left(\frac{\text{days}}{\text{yr}} \right) \times ED_{\text{rec-a}} (20 \text{ yr}) \times EV_{\text{rec-a}} \left(\frac{\text{event}}{\text{day}} \right) \times SA_{\text{rec-a}} (19,652 \text{ cm}^2) \right)}{BW_{\text{rec-a}} (80 \text{ kg})} \right)}$$

and:

$$DFWM_{\text{rec-adj}} \left(\frac{\text{cm}^2\text{-event}}{\text{kg}} \right) = \frac{\left(\frac{EF_{0-2} \left(\frac{\text{days}}{\text{yr}} \right) \times ED_{0-2} (2 \text{ yr}) \times EV_{0-2} \left(\frac{\text{event}}{\text{day}} \right) \times SA_{0-2} (6,365 \text{ cm}^2) \times 10}{BW_{0-2} (15 \text{ kg})} + \frac{EF_{2-6} \left(\frac{\text{days}}{\text{yr}} \right) \times ED_{2-6} (4 \text{ yr}) \times EV_{2-6} \left(\frac{\text{event}}{\text{day}} \right) \times SA_{2-6} (6,365 \text{ cm}^2) \times 3}{BW_{2-6} (15 \text{ kg})} + \frac{EF_{6-16} \left(\frac{\text{days}}{\text{yr}} \right) \times ED_{6-16} (10 \text{ yr}) \times EV_{6-16} \left(\frac{\text{event}}{\text{day}} \right) \times SA_{6-16} (19,652 \text{ cm}^2) \times 3}{BW_{6-16} (80 \text{ kg})} + \frac{EF_{16-26} \left(\frac{\text{days}}{\text{yr}} \right) \times ED_{16-26} (10 \text{ yr}) \times EV_{16-26} \left(\frac{\text{event}}{\text{day}} \right) \times SA_{16-26} (19,652 \text{ cm}^2) \times 1}{BW_{16-26} (80 \text{ kg})} \right)}$$

- Total

$$SL_{\text{rec-wat-tottce}} \left(\frac{\mu\text{g}}{\text{L}} \right) = \frac{1}{\frac{1}{SL_{\text{rec-wat-ingtce}}} + \frac{1}{SL_{\text{rec-wat-dertce}}}}$$

4.6.2.7 Supporting Equations

- Child

$$ED_{\text{rec-c}}(6 \text{ yr}) = ED_{0-2}(2 \text{ yr}) + ED_{2-6}(4 \text{ yr})$$

$$BW_{\text{rec-c}}(15 \text{ kg}) = \frac{ED_{0-2}(2 \text{ yr}) \times BW_{0-2}(15 \text{ kg}) + ED_{2-6}(4 \text{ yr}) \times BW_{2-6}(15 \text{ kg})}{ED_{0-2}(2 \text{ yr}) + ED_{2-6}(4 \text{ yr})}$$

$$EF_{\text{rec-c}} \left(\frac{\text{days}}{\text{yr}} \right) = \frac{ED_{0-2}(2 \text{ yr}) \times EF_{0-2} \left(\frac{\text{days}}{\text{yr}} \right) + ED_{2-6}(4 \text{ yr}) \times EF_{2-6} \left(\frac{\text{days}}{\text{yr}} \right)}{ED_{0-2}(2 \text{ yr}) + ED_{2-6}(4 \text{ yr})}$$

$$ET_{\text{event-rec-c}} \left(\frac{\text{hrs}}{\text{event}} \right) = \frac{ED_{0-2}(2 \text{ yr}) \times ET_{\text{event-rec}} \left(\frac{\text{hrs}}{\text{event}} \right) + ED_{2-6}(4 \text{ yr}) \times ET_{\text{event-(2-6)}} \left(\frac{\text{hrs}}{\text{event}} \right)}{ED_{0-2}(2 \text{ yr}) + ED_{2-6}(4 \text{ yr})}$$

$$EV_{\text{rec-c}} \left(\frac{\text{event}}{\text{day}} \right) = \frac{ED_{0-2}(2 \text{ yr}) \times EV_{0-2} \left(\frac{\text{event}}{\text{day}} \right) + ED_{2-6}(4 \text{ yr}) \times EV_{2-6} \left(\frac{\text{event}}{\text{day}} \right)}{ED_{0-2}(2 \text{ yr}) + ED_{2-6}(4 \text{ yr})}$$

$$SA_{\text{rec-c}}(6,365 \text{ cm}^2) = \frac{ED_{0-2}(2 \text{ yr}) \times SA_{0-2}(6,365 \text{ cm}^2) + ED_{2-6}(4 \text{ yr}) \times SA_{2-6}(6,365 \text{ cm}^2)}{ED_{0-2}(2 \text{ yr}) + ED_{2-6}(4 \text{ yr})}$$

$$IRW_{\text{rec-c}} \left(\frac{0.12 \text{ L}}{\text{hr}} \right) = \frac{ED_{0-2}(2 \text{ yr}) \times IRW_{0-2} \left(\frac{0.12 \text{ L}}{\text{hr}} \right) + ED_{2-6}(4 \text{ yr}) \times IRW_{2-6} \left(\frac{0.12 \text{ L}}{\text{hr}} \right)}{ED_{0-2}(2 \text{ yr}) + ED_{2-6}(4 \text{ yr})}$$

- Adult

$$ED_{\text{rec-a}}(20 \text{ yr}) = ED_{6-16}(10 \text{ yr}) + ED_{16-26}(10 \text{ yr})$$

$$BW_{\text{rec-a}}(80 \text{ kg}) = \frac{ED_{6-16}(10 \text{ yr}) \times BW_{6-16}(80 \text{ kg}) + ED_{16-26}(10 \text{ yr}) \times BW_{16-26}(80 \text{ kg})}{ED_{6-16}(10 \text{ yr}) + ED_{16-26}(10 \text{ yr})}$$

$$EF_{\text{rec-a}}\left(\frac{\text{days}}{\text{yr}}\right) = \frac{ED_{6-16}(10 \text{ yr}) \times EF_{6-16}\left(\frac{\text{days}}{\text{yr}}\right) + ED_{16-26}(10 \text{ yr}) \times EF_{16-26}\left(\frac{\text{days}}{\text{yr}}\right)}{ED_{6-16}(10 \text{ yr}) + ED_{16-26}(10 \text{ yr})}$$

$$ET_{\text{event-rec-a}}\left(\frac{\text{hrs}}{\text{event}}\right) = \frac{ED_{6-16}(10 \text{ yr}) \times ET_{\text{event-(6-16)}}\left(\frac{\text{hrs}}{\text{event}}\right) + ED_{16-26}(10 \text{ yr}) \times ET_{\text{event-(16-26)}}\left(\frac{\text{hrs}}{\text{event}}\right)}{ED_{6-16}(10 \text{ yr}) + ED_{16-26}(10 \text{ yr})}$$

$$EV_{\text{rec-a}}\left(\frac{\text{event}}{\text{day}}\right) = \frac{ED_{6-16}(10 \text{ yr}) \times EV_{6-16}\left(\frac{\text{event}}{\text{day}}\right) + ED_{16-26}(10 \text{ yr}) \times EV_{16-26}\left(\frac{\text{event}}{\text{day}}\right)}{ED_{6-16}(10 \text{ yr}) + ED_{16-26}(10 \text{ yr})}$$

$$SA_{\text{rec-a}}(19,652 \text{ cm}^2) = \frac{ED_{6-16}(10 \text{ yr}) \times SA_{6-16}(19,652 \text{ cm}^2) + ED_{16-26}(10 \text{ yr}) \times SA_{16-26}(19,652 \text{ cm}^2)}{ED_{6-16}(10 \text{ yr}) + ED_{16-26}(10 \text{ yr})}$$

$$IRW_{\text{rec-a}}\left(\frac{0.11 \text{ L}}{\text{hr}}\right) = \frac{ED_{6-16}(10 \text{ yr}) \times IRW_{6-16}\left(\frac{0.124 \text{ L}}{\text{hr}}\right) + ED_{16-26}(10 \text{ yr}) \times IRW_{16-26}\left(\frac{0.098 \text{ L}}{\text{hr}}\right)}{ED_{6-16}(10 \text{ yr}) + ED_{16-26}(10 \text{ yr})}$$

- Age-adjusted

$$ED_{\text{rec}}(26 \text{ yr}) = ED_{0-2}(2 \text{ yr}) + ED_{2-6}(4 \text{ yr}) + ED_{6-16}(10 \text{ yr}) + ED_{16-26}(10 \text{ yr})$$

$$EF_{\text{rec}}\left(\frac{\text{days}}{\text{yr}}\right) = \frac{\left(ED_{0-2}(2 \text{ yr}) \times EF_{0-2}\left(\frac{\text{days}}{\text{yr}}\right) + ED_{2-6}(4 \text{ yr}) \times EF_{2-6}\left(\frac{\text{days}}{\text{yr}}\right) + \right.}{\left. ED_{6-16}(10 \text{ yr}) \times EF_{6-16}\left(\frac{\text{days}}{\text{yr}}\right) + ED_{16-26}(10 \text{ yr}) \times EF_{16-26}\left(\frac{\text{days}}{\text{yr}}\right) \right)}{ED_{0-2}(2 \text{ yr}) + ED_{2-6}(4 \text{ yr}) + ED_{6-16}(10 \text{ yr}) + ED_{16-26}(10 \text{ yr})}$$

4.7 Ingestion of Fish

The fish RSL represents the concentration, in the fish, that can be consumed. Note: the consumption rate for fish is not age adjusted for this land use. Also, the SL calculated for fish is not for surface water or soil but is for fish tissue.

The ingestion of fish land use is not provided in the Generic Tables but RSLs can be created by using the Calculator.

4.7.1 Noncarcinogenic

The ingestion of fish equation, presented here, contains the following exposure route:

- consumption of fish.

$$SL_{\text{res-fsh-ingn}} \left(\frac{\text{mg}}{\text{kg}} \right) = \frac{\text{THQ} \times \text{AT}_{\text{res-a}} \left(\frac{365 \text{ days}}{\text{yr}} \times \text{ED}_{\text{res}} (26 \text{ yr}) \right) \times \text{BW}_{\text{res-a}} (80 \text{ kg})}{\left(\frac{1}{\text{RfDo}} \left(\frac{\text{mg}}{\text{kg-day}} \right) \right) \times \left(\frac{10^{-6} \text{ kg}}{\text{mg}} \right) \times \text{EF}_{\text{res}} \left(\frac{350 \text{ days}}{\text{yr}} \right) \times \text{ED}_{\text{res}} (26 \text{ yr}) \times \text{IRFI}_{\text{res-a}} \left(\frac{\text{mg}}{\text{day}} \right)}$$

4.7.2 Carcinogenic

The ingestion of fish equation, presented here, contains the following exposure route:

- consumption of fish

$$SL_{\text{res-fsh-ingc}} \left(\frac{\text{mg}}{\text{kg}} \right) = \frac{\text{TR} \times \text{AT}_{\text{res}} \left(\frac{365 \text{ days}}{\text{yr}} \times \text{LT} (70 \text{ yrs}) \right) \times \text{BW}_{\text{res-a}} (80 \text{ kg})}{\text{CSF}_o \left(\frac{\text{mg}}{\text{kg-day}} \right)^{-1} \times \left(\frac{10^{-6} \text{ kg}}{\text{mg}} \right) \times \text{EF}_{\text{res}} \left(\frac{350 \text{ days}}{\text{yr}} \right) \times \text{ED}_{\text{res}} (26 \text{ yr}) \times \text{IRFI}_{\text{res-a}} \left(\frac{\text{mg}}{\text{day}} \right)}$$

4.8 Soil to Groundwater

The soil to groundwater scenario was developed to identify concentrations in soil that have the potential to contaminate groundwater above risk based RSLs or MCLs. Migration of contaminants from soil to groundwater can be envisioned as a two-stage process: (1) release of contaminant from soil to soil leachate and (2) transport of the contaminant through the underlying soil and aquifer to a receptor well. The soil to groundwater scenario considers both of these fate and transport mechanisms. First, the acceptable groundwater concentration is multiplied by a

dilution factor to obtain a target leachate concentration. For example, if the dilution factor is 10 and the MCL is 0.05 mg/L, the target soil leachate concentration would be 0.5 mg/L. The partition equation (presented in the Soil Screening Guidance documents) is then used to calculate the total soil concentration corresponding to this soil leachate concentration.

These equations are used to calculate screening levels in soil (SSLs) that are protective of groundwater. SSLs are either back-calculated from protective risk-based ground water concentrations or based on MCLs. The SSLs were designed for use during the early stages of a site evaluation when information about subsurface conditions may be limited. Because of this constraint, the equations used are based on conservative, simplifying assumptions about the release and transport of contaminants in the subsurface. Migration of contaminants from soil to groundwater can be envisioned as a two-stage process: (1) release of contaminant in soil leachate and (2) transport of the contaminant through the underlying soil and aquifer to a receptor well. The SSL methodology considers both of these fate and transport mechanisms.

The SSLs protective of groundwater, provided in the generic tables and the calculator, are all risk-based concentrations based on three phases (vapor, soil and water). No substitution for C_{sat} is performed. If the risk-based concentration exceeds C_{sat} , the resulting SSL concentration may be overly protective. This is because the dissolved, absorbed and vapor concentrations cease to rise linearly as soil concentration increases above the C_{sat} level (pure product or nonaqueous phase liquid (NAPL) is present). The SSL model used in the RSL calculator is not a four phase model. If a NAPL is present at your site more sophisticated models may be necessary.

SSLs are provided for metals in the Generic Tables based on Kds from the Soil Screening Guidance Exhibit C-4 <<https://epa.gov/superfund/superfund-soil-screening-guidance>> . According to Appendix C,

"Exhibit C-4 provides pH-specific soil-water partition coefficients (Kd) for metals. Site-specific soil pH measurements can be used to select appropriate Kd values for these metals. Where site-specific soil pH values are not available, values corresponding to a pH of 6.8 should be used."

If a metal is not listed in Exhibit C-4, Kds were taken from Baes, C. F. 1984 (PDF) <<https://semspub.epa.gov/src/document/03/2218730>> (167 pp, 3.0 MB). Kds for organic compounds are calculated from K_{oc} and the fraction of organic carbon in the soil (f_{oc}). Kds for metals are listed below.

This land use is for developing residential default soil screening levels for the protection of groundwater that are presented in the RSL Generic Tables.

Chemical	CAS or EPA ID	Kd	Reference
Aluminum	7429-90-5	1.50E+03	Baes, C.F. 1984
Antimony (metallic)	7440-36-0	4.50E+01	SSG 9355.4-23 July 1996
Arsenic, Inorganic	7440-38-2	2.90E+01	SSG 9355.4-23 July 1996
Barium	7440-39-3	4.10E+01	SSG 9355.4-23 July 1996
Beryllium and compounds	7440-41-7	7.90E+02	SSG 9355.4-23 July 1996
Boron And Borates Only	7440-42-8	3.00E+00	Baes, C.F. 1984
Bromate	15541-45-4	7.50E+00	Baes, C.F. 1984
Cadmium (Diet)	7440-43-9	7.50E+01	SSG 9355.4-23 July 1996
Cadmium (Water)	7440-43-9	7.50E+01	SSG 9355.4-23 July 1996
Chlorine	7782-50-5	2.50E-01	Baes, C.F. 1984
Chromium (III) (Insoluble Salts)	16065-83-1	1.80E+06	SSG 9355.4-23 July 1996
Chromium (VI)	18540-29-9	1.90E+01	SSG 9355.4-23 July 1996
Chromium, Total	7440-47-3	1.80E+06	SSG 9355.4-23 July 1996
Cobalt	7440-48-4	4.50E+01	Baes, C.F. 1984
Copper	7440-50-8	3.50E+01	Baes, C.F. 1984
Cyanide (CN ⁻)	57-12-5	9.90E+00	SSG 9355.4-23 July 1996
Fluoride	16984-48-8	1.50E+02	Surrogate Value from Fluorine (Soluble Fluoride)
Fluorine (Soluble Fluoride)	7782-41-4	1.50E+02	Baes, C.F. 1984
Hydrogen Cyanide (HCN)	74-90-8	9.90E+00	Surrogate value from Cyanide

Chemical	CAS or EPA ID	Kd	Reference
Iodine	7553-56-2	6.0E+01	Baes, C.F. 1984
Iron	7439-89-6	2.50E+01	Baes, C.F. 1984
Lead and Compounds	7439-92-1	9.00E+02	Baes, C.F. 1984
Lithium	7439-93-2	3.00E+02	Baes, C.F. 1984
Magnesium	7439-95-4	4.50E+00	Baes, C.F. 1984
Manganese (Diet)	7439-96-5	6.50E+01	Baes, C.F. 1984
Manganese (Water)	7439-96-5	6.50E+01	Baes, C.F. 1984
Mercury (elemental)	7439-97-6	5.20E+01	SSG 9355.4-23 July 1996
Methyl Mercury	22967-92-6	7.0E+02	EPA Mercury Study Report to Congress
Molybdenum	7439-98-7	2.00E+01	Baes, C.F. 1984
Nickel Refinery Dust	E715532	1.5E+02	Baes, C.F. 1984
Nickel Soluble Salts	7440-02-0	6.50E+01	SSG 9355.4-23 July 1996
Phosphorus, White	7723-14-0	3.50E+00	Baes, C.F. 1984
Selenium	7782-49-2	5.00E+00	SSG 9355.4-23 July 1996
Silver	7440-22-4	8.30E+00	SSG 9355.4-23 July 1996
Sodium	7440-23-5	1.00E+02	Baes, C.F. 1984
Sodium Fluoride	7681-49-4	1.50E+02	Surrogate Value from Fluorine (Soluble Fluoride)
Strontium, Stable	7440-24-6	3.50E+01	Baes, C.F. 1984
Thallium (Soluble Salts)	7440-28-0	7.10E+01	SSG 9355.4-23 July 1996
Tin	7440-31-5	2.50E+02	Baes, C.F. 1984

Chemical	CAS or EPA ID	Kd	Reference
Tungsten	7440-33-7	1.5E+02	Baes, C.F. 1984
Uranium	7440-62-2	4.50E+02	Baes, C.F. 1984
Vanadium and Compounds	7440-62-2	1.00E+03	SSG 9355.4-23 July 1996
Vanadium, Metallic	7440-62-2	1.00E+03	SSG 9355.4-23 July 1996
Zinc (Metallic)	7440-66-6	6.20E+01	SSG 9355.4-23 July 1996
Zirconium	7440-67-7	3.00E+03	Baes, C.F. 1984

Because Kds vary greatly by soil type, it is highly recommended that site-specific Kds be determined and used to develop SSLs.

The more protective of the carcinogenic and noncarcinogenic SLs is selected to calculate the SSL.

4.8.1 Noncarcinogenic Tapwater Equations for SSLs

The tapwater equations, presented in Section 4.1.2.1, are used to calculate the noncarcinogenic SSLs for volatiles and nonvolatiles. If the contaminant is a volatile, ingestion, dermal and inhalation exposure routes are considered. If the contaminant is not a volatile, only ingestion and dermal are considered.

4.8.2 Carcinogenic Tapwater Equations for SSLs

The tapwater equations, presented in Section 4.1.2.3, are used to calculate the carcinogenic SSLs for volatiles and nonvolatiles. Sections 4.1.2.4 and 4.1.2.5 present the mutagenic and vinyl chloride equations, respectively. If the contaminant is a volatile, ingestion, dermal and inhalation exposure routes are considered. If the contaminant is not a volatile, only ingestion and dermal are considered.

4.8.3 Method 1 for SSL Determination

Method 1 employs a partitioning equation for migration to groundwater and defaults are provided. This method is used to generate the download default tables. If H' is not available, SSL can still be calculated. H' changes when groundwater temperature changes. Please see section 4.9.9 of this user guide for H' determination at temperature other than 25°C.

- method 1.

$$SSL \left(\frac{\text{mg}}{\text{kg}} \right) = C_{\text{water}} \left(\frac{\text{mg}}{\text{L}} \right) \times \left[K_d \left(\frac{\text{L}}{\text{kg}} \right) + \left(\frac{\theta_w \left(\frac{0.3 L_{\text{water}}}{L_{\text{soil}}} \right) + \theta_a \left(\frac{L_{\text{air}}}{L_{\text{soil}}} \right) \times H'}{\rho_b \left(\frac{1.5 \text{ kg}}{\text{L}} \right)} \right)$$

where:

$$C_{\text{water}} \left(\frac{\text{mg}}{\text{L}} \right) = SL \left(\frac{\mu\text{g}}{\text{L}} \right) \times \left(\frac{\text{mg}}{1000 \mu\text{g}} \right) \times \text{DAF}$$

where:

$$SL \left(\frac{\mu\text{g}}{\text{L}} \right) = \text{MCL} \left(\frac{\mu\text{g}}{\text{L}} \right); \text{RSL} \left(\frac{\mu\text{g}}{\text{L}} \right); \text{RML} \left(\frac{\mu\text{g}}{\text{L}} \right); \text{ or PRG} \left(\frac{\mu\text{g}}{\text{L}} \right)$$

$$\theta_a \left(\frac{L_{\text{air}}}{L_{\text{soil}}} \right) = n \left(\frac{L_{\text{pore}}}{L_{\text{soil}}} \right) - \theta_w \left(\frac{0.3 L_{\text{water}}}{L_{\text{soil}}} \right); \quad n \left(\frac{L_{\text{pore}}}{L_{\text{soil}}} \right) = 1 - \frac{\rho_b \left(\frac{1.5 \text{ kg}}{\text{L}} \right)}{\rho_s \left(\frac{2.65 \text{ kg}}{\text{L}} \right)}$$

and:

$$K_d \left(\frac{\text{L}}{\text{kg}} \right) = f_{\text{oc}} \left(\frac{0.002 \text{ g-carbon}}{\text{g-soil}} \right) \times K_{\text{oc}} \left(\frac{\text{L}}{\text{kg}} \right), \text{ for organic compounds;}$$

$K_d \left(\frac{\text{L}}{\text{kg}} \right)$ values for inorganic compounds are listed in the user guide.

The fraction of organic carbon (f_{oc}) selected for this equation is 0.002. This is the default for subsurface soil identified in U.S. EPA 1996b, Sections 2.5.2 and 2.5.7. According to this source, soil organic carbon decreases rapidly with depth. Note that the default f_{oc} in section “4.9.4 Infinite Source Chronic Volatilization Factor (VF_{ulim})” is 0.006, which is the default for surface soil from the same study.

4.8.4 Method 2 for SSL Determination

Method 2 employs a mass-limit equation for migration to groundwater and site-specific information is required. This method can be used in the calculator portion of this website.

- method 2.

$$SSL \left(\frac{\text{mg}}{\text{kg}} \right) = \frac{C_{\text{water}} \left(\frac{\text{mg}}{\text{L}} \right) \times I \left(\frac{0.18 \text{ m}}{\text{yr}} \right) \times ED (70 \text{ yr})}{\rho_b \left(\frac{1.5 \text{ kg}}{\text{L}} \right) \times d_s \left(\frac{\text{mg}}{\text{kg}} \right)}$$

where:

$$C_{\text{water}} \left(\frac{\text{mg}}{\text{L}} \right) = SL \left(\frac{\mu\text{g}}{\text{L}} \right) \times \left(\frac{\text{mg}}{1000 \mu\text{g}} \right) \times \text{DAF}$$

where:

$$SL \left(\frac{\mu\text{g}}{\text{L}} \right) = \text{MCL} \left(\frac{\mu\text{g}}{\text{L}} \right); \text{RSL} \left(\frac{\mu\text{g}}{\text{L}} \right); \text{RML} \left(\frac{\mu\text{g}}{\text{L}} \right); \text{ or } \text{PRG} \left(\frac{\mu\text{g}}{\text{L}} \right)$$

4.8.5 Determination of the Dilution Factor

The SSL values in the download tables are based on a dilution factor of 1. If one wishes to use the calculator to calculate screening levels using the SSL guidance for a source up to 0.5 acres, then a dilution factor of 20 can be used. If all of the parameters needed to calculate a site-specific dilution factor are known, they may be entered.

- Dilution Attenuation Factor.

$$\text{Dilution Attenuation Factor (DAF)} = 1 + \frac{K \left(\frac{\text{m}}{\text{yr}} \right) \times i \left(\frac{\text{m}}{\text{m}} \right) \times d(\text{m})}{I \left(\frac{0.18 \text{ m}}{\text{yr}} \right) \times L(\text{m})}$$

where:

$$d(\text{m}) = \left(0.0112 \times L^2(\text{m}) \right)^{0.5} + d_a(\text{m}) \times \left[1 - \exp \left(\frac{-L(\text{m}) \times I \left(\frac{0.18 \text{ m}}{\text{yr}} \right)}{K \left(\frac{\text{m}}{\text{yr}} \right) \times i \left(\frac{\text{m}}{\text{m}} \right) \times d_a(\text{m})} \right) \right]$$

4.8.6 Conservative and Simplifying Assumptions for the Soil to Groundwater Scenario

The SSL scenario was designed for use during the early stages of a site evaluation when information about subsurface conditions may be limited. Because of this constraint, methods 1 and 2 are based on conservative, simplifying assumptions about the release and transport of contaminants in the subsurface. These assumptions include:

- The source is infinite (i.e., steady-state concentrations will be maintained in ground water over the exposure period of interest).
- Contaminants are uniformly distributed throughout the zone of contamination.
- Soil contamination extends from the surface to the water table (i.e., adsorption sites are filled in the unsaturated zone beneath the area of contamination).
- There is no contaminant loss due to biological degradation or volatilization in the unsaturated zone.
- Equilibrium soil/water partitioning is instantaneous and linear in the contaminated soil.
- The receptor well is at the edge of the source (i.e., there is no dilution from recharge downgradient of the site) and is screened within the plume.
- The aquifer is unconsolidated and unconfined (surficial).
- Aquifer properties are homogeneous and isotropic.
- Chelating or complexing agents not present.
- No facilitated transport (e.g., colloidal transport) of inorganic contaminants in aquifer.

RSLs developed using this methodology can be viewed as evolving risk-based levels that can be refined as more site information becomes available. The early use of the methodology at a site will help focus further subsurface investigations on areas of true concern with respect to ground water quality and will provide information on soil characteristics, aquifer characteristics, and contaminant properties that can be built upon as a site evaluation progresses.

4.9 Supporting Equations and Parameter Discussion

There are two parts of the above land use equations that require further explanation. They are the inhalation variables: the particulate emission factor (PEF) and the volatilization factor (VF).

4.9.1 Wind-driven Particulate Emission Factor (PEF)

Inhalation of contaminants adsorbed to respirable particles (PM₁₀) was assessed using a default PEF equal to $1.36 \times 10^9 \text{ m}^3/\text{kg}$. This equation relates the contaminant concentration in soil with the concentration of respirable particles in the air due to fugitive dust emissions from contaminated soils. The generic PEF was derived using default values that correspond to a receptor point concentration of approximately $0.76 \text{ } \mu\text{g}/\text{m}^3$. The relationship is derived by Cowherd (1985) for a rapid assessment procedure applicable to a typical hazardous waste site, where the surface contamination provides a relatively continuous and constant potential for emission over an extended period of time (e.g., years). This represents an annual average emission rate based on wind erosion that should be compared with chronic health criteria; it is not appropriate for evaluating the potential for more acute exposures. Definitions of the input variables are in Table 1.

With the exception of specific heavy metals, the PEF does not appear to significantly affect most soil screening levels. The equation forms the basis for deriving a generic PEF for the inhalation pathway. For more details regarding specific parameters used in the PEF model, refer to Appendix D of the Supplemental Soil Screening Guidance

<<https://epa.gov/superfund/superfund-soil-screening-guidance>>. The use of alternate values on a specific site should be justified and presented in an Administrative Record if considered in CERCLA remedy selection.

$$\text{PEF} \left(\frac{\text{m}_{\text{air}}^3}{\text{kg}_{\text{soil}}} \right) = \frac{\frac{Q}{C_{\text{wind}}} \left(\frac{\left(\frac{\text{g}}{\text{m}^2 \cdot \text{s}} \right)}{\left(\frac{\text{kg}}{\text{m}^3} \right)} \right) \times \left(\frac{3,600 \text{ s}}{\text{hr}} \right)}{0.036 \times (1 - V) \times \left(\frac{U_m \left(\frac{\text{m}}{\text{s}} \right)}{U_t \left(\frac{\text{m}}{\text{s}} \right)} \right)^3 \times F(x)}$$

where:

$$\frac{Q}{C_{\text{wind}}} \left(\frac{\left(\frac{\text{g}}{\text{m}^2 \cdot \text{s}} \right)}{\left(\frac{\text{kg}}{\text{m}^3} \right)} \right) = A \times \exp \left[\frac{(\ln(A_s(\text{acre})) - B)^2}{C} \right]$$

and:

$$\text{if } x < 2, F(x) = 1.91207 - 0.0278085 + 0.48113x^2 - 1.09871x^3 + 0.335341x^4$$

$$\text{if } x \geq 2, F(x) = 0.18 (8x^3 + 12x) e^{(-x^2)}$$

where:

$$x = 0.886 \times \left(\frac{U_t \left(\frac{\text{m}}{\text{s}} \right)}{U_m \left(\frac{\text{m}}{\text{s}} \right)} \right)$$

Note: the generic PEF evaluates wind-borne emissions and does not consider dust emissions from traffic or other forms of mechanical disturbance that could lead to greater emissions than assumed here.

4.9.2 Vehicle traffic-driven Particulate Emission Factor (PEF_{sc})

The equation to calculate the subchronic particulate emission factor (PEF_{sc}) is significantly different from the residential and non-residential PEF equations. The PEF_{sc} focuses exclusively on emissions from truck traffic on unpaved roads, which typically contribute the majority of dust emissions during construction. This equation requires estimates of parameters such as the number of days with at least 0.01 inches of rainfall, the mean vehicle weight, and the sum of fleet vehicle distance traveled during construction.

The number of days with at least 0.01 inches of rainfall can be estimated using Exhibit 5-2 in the supplemental soil screening guidance (PDF) <<https://semspub.epa.gov/src/document/hq/175878>> (187 pp, 2.2 MB). Mean vehicle weight (W) can be estimated by assuming the numbers and weights of

different types of vehicles. For example, assuming that the daily unpaved road traffic consists of 20 two-ton cars and 10 twenty-ton trucks, the mean vehicle weight would be:

$$W = [(20 \text{ cars} \times 2 \text{ tons/car}) + (10 \text{ trucks} \times 20 \text{ tons/truck})] / 30 \text{ vehicles} = 8 \text{ tons}$$

The sum of the fleet vehicle kilometers traveled during construction (Σ VKT) can be estimated based on the size of the area of surface soil contamination, assuming the configuration of the unpaved road, and the amount of vehicle traffic on the road. For example, if the area of surface soil contamination is 0.5 acres (or 2,024 m²), and one assumes that this area is configured as a square with the unpaved road segment dividing the square evenly, the road length would be equal to the square root of 2,024 m², 45 m (or 0.045 km). Assuming that each vehicle travels the length of the road once per day, 5 days per week for a total of 6 months, the total fleet vehicle kilometers traveled would be:

$$\Sigma \text{ VKT} = 30 \text{ vehicles} \times 0.045 \text{ km/day} \times (52 \text{ weeks/year} \div 2) \times 5 \text{ days/wk} = 175.5 \text{ km}$$

$$PEF_{sc} \left(\frac{m^3_{air}}{kg_{soil}} \right) = \left[\frac{\frac{Q}{C_{sr}} \left(\frac{\left(\frac{g}{m^2-s} \right)}{\left(\frac{kg}{m^3} \right)} \right) \times \frac{1}{F_D(0.18584)} \times T_t(7,200,000 \text{ s}) \times A_R (m^2)}{2.6 \times \left(\frac{s}{12} \right)^{0.8} \times \left(\frac{W(\text{tons})}{3} \right)^{0.4} \times \frac{\left(\frac{365 \text{ days}}{yr} \right) - p \left(\frac{\text{days}}{yr} \right)}{\left(\frac{365 \text{ days}}{yr} \right)} \times 281.9 \times \sum VKT (km)} \right]$$

where:

$$\frac{Q}{C_{sr}} \left(\frac{\left(\frac{g}{m^2-s} \right)}{\left(\frac{kg}{m^3} \right)} \right) = A \times \exp \left[\frac{(\ln(A_s(\text{acre})) - B)^2}{C} \right]$$

$$A_R (m^2) = L_R (\text{ft}) \times W_R (20 \text{ ft}) \times 0.092903 \left(\frac{m^2}{ft^2} \right)$$

$$W(\text{tons}) = \frac{\left(\text{number of cars} \times \frac{\text{tons}}{\text{car}} + \text{number of trucks} \times \frac{\text{tons}}{\text{truck}} \right)}{\text{total vehicles}}$$

$$\sum VKT (km) = \text{total vehicles} \times \text{distance} \left(\frac{km}{day} \right) \times EW_{con} \left(\frac{50 \text{ wk}}{yr} \right) \times DW_{con} \left(\frac{7 \text{ days}}{wk} \right)$$

$$T_t(7,200,000 \text{ s}) = ED_{con} (1 \text{ year}) \times EF_{con} \left(\frac{250 \text{ days}}{yr} \right) \times ET_{con} \left(\frac{8 \text{ hrs}}{day} \right) \times \left(\frac{3,600 \text{ s}}{hr} \right)$$

$$F_D(0.18584) = 0.1852 + \left(\frac{5.3537}{t_c(8,400 \text{ hrs})} \right) + \left(\frac{-9.6318}{t_c(8,400 \text{ hrs})^2} \right)$$

$$t_c(8,400 \text{ hrs}) = ED_{con} (1 \text{ year}) \times EW_{con} \left(\frac{50 \text{ wk}}{yr} \right) \times \left(\frac{7 \text{ days}}{wk} \right) \times \left(\frac{24 \text{ hr}}{day} \right)$$

4.9.3 Other than vehicle traffic-driven Particulate Emission Factor (PEF'_{sc})

Other than emissions from unpaved road traffic, the construction worker may also be exposed to particulate matter emissions from wind erosion, excavation soil dumping, dozing, grading, and tilling or similar operations PEF'_{sc}. These operations may occur separately or concurrently and the duration of each operation may be different. For these reasons, the total unit mass emitted from each operation is calculated separately and the sum is normalized over the entire area of contamination and over the entire time during which construction activities take place. Equation E-26 in the supplemental soil screening guidance (PDF)

<<https://semspub.epa.gov/src/document/hq/175878>> (187 pp, 2.2 MB) was used.

$$PEF'_{sc} \left(\frac{m^3}{kg} \right) = \frac{Q}{C_{sa}} \left(\frac{\left(\frac{g}{m^2-s} \right)}{\left(\frac{kg}{m^3} \right)} \right) \times \frac{1}{F_D(0.18584)} \times \frac{1}{<J'_T> \left(\frac{g}{m^2-s} \right)}$$

where:

$$\frac{Q}{C_{sa}} \left(\frac{\left(\frac{g}{m^2-s} \right)}{\left(\frac{kg}{m^3} \right)} \right) = A \times \exp \left[\frac{(\ln(A_c(\text{acre})) - B)^2}{C} \right]$$

$$<J'_T> \left(\frac{g}{m^2-s} \right) = \frac{M_{wind}^{PC}(g) + M_{excav}(g) + M_{doz}(g) + M_{grade}(g) + M_{till}(g)}{A_{surf} (m^2) \times T_t(7,200,000 \text{ s})}$$

$$M_{wind}^{PC}(g) = 0.036 \times (1 - V) \times \left(\frac{U_m \left(\frac{m}{s} \right)}{U_t \left(\frac{m}{s} \right)} \right)^3 \times F(x) \times A_{surf} (m^2) \times ED_{con}(1 \text{ year}) \times \left(\frac{8,760 \text{ hr}}{yr} \right)$$

$$M_{excav}(g) = 0.35 \times 0.0016 \times \left(\frac{U_m \left(\frac{m}{s} \right)}{2.2} \right)^{1.3} \times \rho_{soil} \left(\frac{mg}{m^3} \right) \times A_{excav} (m^2) \times d_{excav}(m) \times NA_{dump} \times \left(\frac{1,000 \text{ g}}{kg} \right)$$

$$M_{doz}(g) = 0.75 \times \frac{0.45 \times S_{doz}(\%)^{1.5}}{(M_{m-doz}(\%))^{1.4}} \times \frac{\sum VKT_{doz}(km)}{S_{doz} \left(\frac{km}{hr} \right)} \times \left(\frac{1,000 \text{ g}}{kg} \right)$$

$$M_{grade}(g) = 0.60 \times 0.0056 \times S_{grade} \left(\frac{km}{hr} \right)^2 \times \sum VKT_{grade}(km) \times \left(\frac{1,000 \text{ g}}{kg} \right)$$

and:

$$M_{till}(g) = 1.1 \times s_{till}(\%)^{0.6} \times A_{c-till}(\text{acres}) \times \left(\frac{4047 \text{ m}^2}{\text{acre}} \right) \times \left(\frac{10^{-4} \text{ ha}}{m^2} \right) \left(\frac{1,000 \text{ g}}{kg} \right) \times NA_{till}$$

where: =

$$\sum VKT_{grade}(km) = A_{c-grade}(\text{acres}) \times \left(\frac{4047 \text{ m}^2}{\text{acre}} \right) \times \frac{1}{B_{l-grade}(m)} \times \frac{1}{\left(\frac{1,000 \text{ m}}{km} \right)} \times NA_{grade}$$

$$\sum VKT_{doz}(km) = A_{c-doz}(\text{acres}) \times \left(\frac{4047 \text{ m}^2}{\text{acre}} \right) \times \frac{1}{B_{l-doz}(m)} \times \frac{1}{\left(\frac{1,000 \text{ m}}{km} \right)} \times NA_{doz}$$

$$T_t(7,200,000 \text{ s}) = ED_{con}(1 \text{ year}) \times EF_{con} \left(\frac{250 \text{ days}}{yr} \right) \times ET_{con} \left(\frac{8 \text{ hrs}}{\text{day}} \right) \times \left(\frac{3,600 \text{ s}}{hr} \right)$$

$$F_D(0.18584) = 0.1852 + \left(\frac{5.3537}{t_c(8,400 \text{ hrs})} \right) + \left(\frac{-9.6318}{t_c(8,400 \text{ hrs})^2} \right)$$

$$t_c(8,400 \text{ hrs}) = ED_{con}(1 \text{ year}) \times (50 \text{ wk}) \times (7 \text{ days}) \times (24 \text{ hr})$$

$$\tau_c (8,400 \text{ hrs}) = \text{ED}_{\text{con}} (1 \text{ year}) \times \text{EW}_{\text{con}} \left(\frac{\text{yr}}{\text{yr}} \right) \times \left(\frac{\text{wk}}{\text{wk}} \right) \times \left(\frac{\text{day}}{\text{day}} \right)$$

and:

$$\text{if } x < 2, F(x) = 1.91207 - 0.0278085x + 0.48113x^2 - 1.09871x^3 + 0.335341x^4$$

$$\text{if } x \geq 2, F(x) = 0.18 (8x^3 + 12x) e^{-x^2}$$

where:

$$x = 0.886 \times \left(\frac{U_t \left(\frac{\text{m}}{\text{s}} \right)}{U_m \left(\frac{\text{m}}{\text{s}} \right)} \right)$$

4.9.4 Infinite Source Chronic Volatilization Factor (VF_{ulim})

The soil-to-air VF is used to define the relationship between the concentration of the contaminant in soil and the flux of the volatilized contaminant to air. VF is calculated from the equation below using chemical-specific properties and either site-measured or default values for soil moisture, dry bulk density, and fraction of organic carbon in soil. If H' is not available, VF_{ulim} can still be calculated. The Soil Screening Guidance: User's Guide (PDF)

<<https://semspub.epa.gov/src/document/hq/211>> (89 pp, 863 K) describes how to develop site measured values for these parameters.

VF is only calculated for volatile compounds. Volatiles, for the purpose of this guidance, are chemicals with a Henry's Law constant greater than $1 \times 10^{-5} \text{ atm}\cdot\text{m}^3/\text{mole}$ or a vapor pressure greater than 1 mm Hg. The volatile status of a chemical is important for some exposure routes. According to RAGS Part E <<https://epa.gov/risk/risk-assessment-guidance-superfund-rags-part-e>>, dermal absorption to soil is not assessed for volatiles. For the purposes of this guidance, dermal exposure to soil is only quantified if RAGS Part E <<https://epa.gov/risk/risk-assessment-guidance-superfund-rags-part-e>> provides a dermal absorption value in Exhibit 3-4 or the website, regardless of volatility status. The rationale for this is that in the considered soil exposure scenarios, volatile organic compounds would tend to be volatilized from the soil on skin and should be accounted for via inhalation routes in the combined exposure pathway analysis. Further, a chemical must be volatile in order to be included in the calculation of tapwater inhalation. H' changes when groundwater temperature changes. Please see section 4.9.9 of this user guide for H' determination at temperature other than 25°C.

unlimited source model for chronic exposure

$$VF_{\text{ulim}} \left(\frac{\text{m}^3_{\text{air}}}{\text{kg}_{\text{soil}}} \right) = \frac{\frac{Q}{C_{\text{vol}}} \left(\frac{\left(\frac{\text{g}}{\text{m}^2 \cdot \text{s}} \right)}{\left(\frac{\text{kg}}{\text{m}^3} \right)} \right) \times \left(3.14 \times D_A \left(\frac{\text{cm}^2}{\text{s}} \right) \times T(\text{s}) \right)^{1/2} \times \left(\frac{10^{-4} \text{ m}^2}{\text{cm}^2} \right)}{2 \times \rho_b \left(\frac{1.5 \text{ g}}{\text{cm}^3} \right) \times D_A \left(\frac{\text{cm}^2}{\text{s}} \right)}$$

where:

$$\frac{Q}{C_{\text{vol}}} \left(\frac{\left(\frac{\text{g}}{\text{m}^2 \cdot \text{s}} \right)}{\left(\frac{\text{kg}}{\text{m}^3} \right)} \right) = A \times \exp \left[\frac{(\ln(A_s(\text{acre})) - B)^2}{C} \right]$$

and:

$$D_A \left(\frac{\text{cm}^2}{\text{s}} \right) = \frac{\left(\theta_a \left(\frac{0.28 L_{\text{air}}}{L_{\text{soil}}} \right)^{10/3} \times D_{\text{ia}} \left(\frac{\text{cm}^2}{\text{s}} \right) \times H' + \theta_w \left(\frac{0.15 L_{\text{water}}}{L_{\text{soil}}} \right) \times D_{\text{iw}} \left(\frac{\text{cm}^2}{\text{s}} \right) \right) / n^2 \left(\frac{0.43 L_{\text{pore}}}{L_{\text{soil}}} \right)}{\rho_b \left(\frac{1.5 \text{ g}}{\text{cm}^3} \right) \times K_d \left(\frac{\text{cm}^2}{\text{g}} \right) + \theta_w \left(\frac{0.15 L_{\text{water}}}{L_{\text{soil}}} \right) + \theta_a \left(\frac{0.28 L_{\text{air}}}{L_{\text{soil}}} \right) \times H'}$$

where:

$$\theta_a \left(\frac{0.28 L_{\text{air}}}{L_{\text{soil}}} \right) = n \left(\frac{0.43 L_{\text{pore}}}{L_{\text{soil}}} \right) - \theta_w \left(\frac{0.15 L_{\text{water}}}{L_{\text{soil}}} \right) \text{ and: } n \left(\frac{0.43 L_{\text{pore}}}{L_{\text{soil}}} \right) = 1 - \frac{\rho_b \left(\frac{1.5 \text{ g}}{\text{cm}^3} \right)}{\rho_s \left(\frac{2.65 \text{ g}}{\text{cm}^3} \right)}$$

and:

$$K_d \left(\frac{\text{cm}^2}{\text{g}} \right) = f_{\text{oc}} \left(\frac{0.006 \text{ g-carbon}}{\text{g-soil}} \right) \times K_{\text{oc}} \left(\frac{\text{cm}^3}{\text{g}} \right) \text{ only for organics.}$$

The fraction of organic carbon (f_{oc}) selected for this equation is 0.006. This is the default for surface soil identified in U.S. EPA 1996b, Sections 2.4.2 and 2.5.7, and represents the mean value for the top 0.3m of Class B soils. According to this source, soil organic carbon decreases rapidly with depth. Note that the default f_{oc} in section “4.8.3 Method 1 for SSL Determination” is 0.002, which is the default for subsurface soil from the same study.

Diffusivity in Water (cm^2/s)

Diffusivity in water can be calculated from the chemical's molecular weight and density, using the following correlation equation based on WATER9 (U.S. EPA, 2001 (PDF)

<<https://semspub.epa.gov/src/document/03/2218724>> (38 pp, 185 K)):

$$D_{iw} \left(\frac{\text{cm}^2}{\text{s}} \right) = 0.0001518 \times \left(\frac{T^{\circ}\text{C} + 273.16}{298.16} \right) \times \left(\frac{\text{MW} \left(\frac{\text{g}}{\text{mole}} \right)}{\rho \left(\frac{\text{g}}{\text{cm}^3} \right)} \right)^{-0.6}$$

where:

T typically = 25°C

If density is not available use,

$$D_{iw} \left(\frac{\text{cm}^2}{\text{s}} \right) = 0.000222 \times \left(\text{MW} \left(\frac{\text{g}}{\text{mole}} \right) \right)^{-2/3}$$

If density is not available, diffusivity in water can be calculated using the correlation equation based on U.S. EPA (1987). The value for diffusivity in water must be greater than zero. No maximum limit is enforced.

Diffusivity in Air (cm²/s).

Diffusivity in air can be calculated from the chemical's molecular weight and density, using the following correlation equation based on WATER9 (U.S. EPA, 2001 (PDF)

<<https://semspub.epa.gov/src/document/03/2218724>>(38 pp, 185 K)). If density is not available, an alternate equation is provided.:

$$D_{ia} \left(\frac{\text{cm}^2}{\text{s}} \right) = \frac{0.00229 \times (T^{\circ}\text{C} + 273.16)^{1.5} \times \sqrt{0.034 + \left(\frac{1}{\text{MW} \left(\frac{\text{g}}{\text{mole}} \right)} \right) \times \text{MW}_{\text{cor}}}}{\left(\left(\frac{\text{MW} \left(\frac{\text{g}}{\text{mole}} \right)}{2.5 \times \rho \left(\frac{\text{g}}{\text{cm}^3} \right)} \right)^{0.333} + 1.8 \right)^2}$$

where:

T typically = 25°C

$$\text{MW}_{\text{cor}} = \left(1 - 0.000015 \times \text{MW} \left(\frac{\text{g}}{\text{mole}} \right)^2 \right)$$

If MW_{cor} is less than 0.4, then MW_{cor} is set to 0.4.

If density is not available use,

$$D_{ia} \left(\frac{\text{cm}^2}{\text{s}} \right) = 1.9 \times \left(\text{MW} \left(\frac{\text{g}}{\text{mole}} \right)^{-2/3} \right)$$

For dioxins, furans, and dioxin-like PCBs always use,

$$D_{ia} \left(\frac{\text{cm}^2}{\text{s}} \right) = \left(\frac{154 \left(\frac{\text{g}}{\text{mole}} \right)}{\text{MW} \left(\frac{\text{g}}{\text{mole}} \right)} \right)^{0.5} \times 0.068 \left(\frac{\text{cm}^2}{\text{s}} \right)$$

For dioxins, furans, and dioxin-like PCBs, diffusivity in air should always be calculated from the molecular weight using the Graham's Law correlation equation based on December 2003 NAS Review Draft Part I: Volume 3 (pg 4-38) (PDF) <https://cfpub.epa.gov/ncea/iris_drafts/dioxin/nas-review/pdfs/part1_vol3/dioxin_pt1_vol3_ch04_dec2003.pdf> (148 pp, 1.9 MB). In this equation, the unknown diffusivity is solved by correlation to the known diphenyl diffusivity of 0.068 cm²/s and MW of 154 g/mol.

4.9.5 Mass-limit Chronic Volatilization Factor (VF_{mlim})

This Equation presents a model for calculating mass-limit SSLs for the outdoor inhalation of volatiles. This model can be used only if the depth and area of contamination are known or can be estimated with confidence. This equation is presented in the Soil Screening Guidance: User's Guide (PDF) <<https://semspub.epa.gov/src/document/hq/211>> (89 pp, 863 KF <<https://epa.gov/home/pdf-files>>) and the Supplemental Soil Screening Guidance (PDF) <<https://semspub.epa.gov/src/document/hq/175878>> (187 pp, 2.2 MB).

Use of infinite source models to estimate volatilization can violate mass balance considerations, especially for small sources. To address this concern, the Soil Screening Guidance includes a model for calculating a mass-limit SSL that provides a lower limit to the SSL **when the area and depth (i.e., volume) of the source are known or can be estimated reliably.**

A mass-limit SSL represents the level of contaminant in the subsurface that is still protective when the entire volume of contamination volatilizes over the 26-year exposure duration and the level of contaminant at the receptor does not exceed the health-based limit.

To use mass-limit SSLs, determine the area and depth of the source, calculate both standard and mass-limit SSLs, compare them for each chemical of concern and select the higher of the two values.

Note that the equation requires a site-specific determination of the average depth of contamination in the source. Step 3, in the SSG, provides guidance for conducting subsurface sampling to determine source depth. Where the actual average depth of contamination is uncertain, a conservative estimate should be used (e.g., the maximum possible depth in the unsaturated zone). At many sites, the average water table depth may be used unless there is reason to believe that contamination extends below the water table. In this case SSLs do not apply and further investigation of the source in question is needed.

mass limit model for chronic exposure

$$VF_{\text{mlim}} \left(\frac{\text{m}^3_{\text{air}}}{\text{kg}_{\text{soil}}} \right) = \frac{\frac{Q}{C_{\text{vol}}} \left(\frac{\left(\frac{\text{g}}{\text{m}^2 \cdot \text{s}} \right)}{\left(\frac{\text{kg}}{\text{m}^3} \right)} \right) \times \left(T(\text{yr}) \left(3.15 \times \left(\frac{10^7 \text{ s}}{\text{yr}} \right) \right) \right)}{\rho_b \left(\frac{\text{mg}}{\text{m}^3} \right) \times d_s(\text{m}) \times \left(\frac{10^6 \text{ g}}{\text{Mg}} \right)}$$

where:

$$\frac{Q}{C_{\text{vol}}} \left(\frac{\left(\frac{\text{g}}{\text{m}^2 \cdot \text{s}} \right)}{\left(\frac{\text{kg}}{\text{m}^3} \right)} \right) = A \times \exp \left[\frac{(\ln(A_s(\text{acre})) - B)^2}{C} \right]$$

4.9.6 Unlimited Source Subchronic Volatilization Factor for Construction Worker ($VF_{ulim-sc}$)

Equation 5-14 of the supplemental soil screening guidance (PDF)

<https://semspub.epa.gov/src/document/hq/175878> (187 pp, 2.2 MB) is appropriate for calculating the soil-to-air volatilization factor ($VF_{ulim-sc}$) that relates the concentration of a contaminant in soil to the concentration in air resulting from volatilization. The equation for the subchronic dispersion factor for volatiles, Q/C_{sa} , is presented in Equation 5-15 of the supplemental soil screening guidance (PDF) <https://semspub.epa.gov/src/document/hq/175878> (187 pp, 2.2 MB). Q/C_{sa} was derived using EPA's SCREEN3 dispersion model for a hypothetical site under a wide range of meteorological conditions. Unlike the Q/C values for the other scenarios, the Q/C_{sa} for the construction scenario's simple site-specific approach can be modified only to reflect different site sizes between 0.5 and 500 acres; it cannot be modified for climatic zone. Site managers conducting a detailed site-specific analysis for the construction scenario can develop a site-specific Q/C value by running the SCREEN3 model. If H' is not available, $VF_{ulim-sc}$ can still be calculated. Further details on the derivation of Q/C_{sa} can be found in Appendix E (PDF) <https://semspub.epa.gov/src/document/hq/174068.pdf> (42 pp, 779 K) of the supplemental soil screening guidance (PDF) <https://semspub.epa.gov/src/document/hq/175878> (187 pp, 2.2 MB). If H' is not available, D_A can still be calculated. H' changes when groundwater temperature changes. Please see section 4.9.9 of this user guide for H' determination at temperature other than 25°C.

unlimited source model for subchronic exposure

$$VF_{\text{ulim-sc}} \left(\frac{\text{m}^3_{\text{air}}}{\text{kg}_{\text{soil}}} \right) = \frac{\frac{Q}{C_{\text{sa}}} \left(\frac{\left(\frac{\text{g}}{\text{m}^2\text{-s}} \right)}{\left(\frac{\text{kg}}{\text{m}^3} \right)} \right) \times \frac{1}{F_D(0.18584)} \times \left(3.14 \times D_A \left(\frac{\text{cm}^2}{\text{s}} \right) \times T(\text{s}) \right)^{1/2} \times \left(\frac{10^{-4} \text{ m}^2}{\text{cm}^2} \right)}{2 \times \rho_b \left(\frac{1.5 \text{ g}}{\text{cm}^3} \right) \times D_A \left(\frac{\text{cm}^2}{\text{s}} \right)}$$

where:

$$\frac{Q}{C_{\text{sa}}} \left(\frac{\left(\frac{\text{g}}{\text{m}^2\text{-s}} \right)}{\left(\frac{\text{kg}}{\text{m}^3} \right)} \right) = A \times \exp \left[\frac{(\ln(A_s(\text{acre})) - B)^2}{C} \right]$$

$$D_A \left(\frac{\text{cm}^2}{\text{s}} \right) = \frac{\left(\theta_a \left(\frac{0.28 L_{\text{air}}}{L_{\text{soil}}} \right)^{10/3} \times D_{\text{ia}} \left(\frac{\text{cm}^2}{\text{s}} \right) \times H' + \theta_w \left(\frac{0.15 L_{\text{water}}}{L_{\text{soil}}} \right) \times D_{\text{iw}} \left(\frac{\text{cm}^2}{\text{s}} \right) \right) / n^2 \left(\frac{0.43 L_{\text{pore}}}{L_{\text{soil}}} \right)}{\rho_b \left(\frac{1.5 \text{ g}}{\text{cm}^3} \right) \times K_d \left(\frac{\text{cm}^2}{\text{g}} \right) + \theta_w \left(\frac{0.15 L_{\text{water}}}{L_{\text{soil}}} \right) + \theta_a \left(\frac{0.28 L_{\text{air}}}{L_{\text{soil}}} \right) \times H'}$$

$$\theta_a \left(\frac{0.28 L_{\text{air}}}{L_{\text{soil}}} \right) = n \left(\frac{0.43 L_{\text{pore}}}{L_{\text{soil}}} \right) - \theta_w \left(\frac{0.15 L_{\text{water}}}{L_{\text{soil}}} \right) \text{ and: } n \left(\frac{0.43 L_{\text{pore}}}{L_{\text{soil}}} \right) = 1 - \frac{\rho_b \left(\frac{1.5 \text{ g}}{\text{cm}^3} \right)}{\rho_s \left(\frac{2.65 \text{ g}}{\text{cm}^3} \right)}$$

$$K_d \left(\frac{\text{cm}^2}{\text{g}} \right) = f_{\text{oc}} \left(\frac{0.006 \text{ g-carbon}}{\text{g-soil}} \right) \times K_{\text{oc}} \left(\frac{\text{cm}^3}{\text{g}} \right) \text{ only for organics.}$$

$$T(30,240,000 \text{ s}) = ED_{\text{con}}(1 \text{ year}) \times EW_{\text{con}} \left(\frac{50 \text{ wk}}{\text{yr}} \right) \times \left(\frac{7 \text{ days}}{\text{wk}} \right) \times \left(\frac{24 \text{ hr}}{\text{day}} \right) \times \left(\frac{3,600 \text{ s}}{\text{hr}} \right)$$

$$F_D(0.18584) = 0.1852 + \left(\frac{5.3537}{t_c(8,400 \text{ hrs})} \right) + \left(\frac{-9.6318}{t_c(8,400 \text{ hrs})^2} \right)$$

$$t_c(8,400 \text{ hrs}) = ED_{\text{con}}(1 \text{ year}) \times EW_{\text{con}} \left(\frac{50 \text{ wk}}{\text{yr}} \right) \times \left(\frac{7 \text{ days}}{\text{wk}} \right) \times \left(\frac{24 \text{ hr}}{\text{day}} \right)$$

4.9.7 Mass-limit Subchronic Volatilization Factor for Construction Worker ($VF_{\text{mlim-sc}}$)

Because the equations developed to calculate SSLs for the inhalation of volatiles outdoors assume an infinite source, they can violate mass-balance considerations, especially for small sources. To address this concern, a mass-limit SSL equation for this pathway may be used (Equation 5-17 of the supplemental soils screening guidance (PDF)

<<https://semspub.epa.gov/src/document/hq/175878>>(187 pp, 2.2 MB)). This equation can be used only when the volume (i.e., area and depth) of the contaminated soil source is known or can be

estimated with confidence. As discussed above, the simple site-specific approach for calculating construction scenario SSLs uses the same emission model for volatiles as that used in the residential and non-residential scenarios. However, the conservative nature of this model (i.e., it assumes all contamination is at the surface) makes it sufficiently protective of construction worker exposures to volatiles.

4.9.8 Dermal Contact with Water Supporting Equations

RAGS Part E stresses the determination of whether a chemical is within the effective predictive domain (EPD) for the determination of dermal permeability constant (K_p) applicability. The RSL output provides determination of whether or not a chemical is within the EPD. The RSL output also displays our determination of the fraction of the chemical that is ultimately absorbed (FA). FA depends strongly on the chemical's lipophilic characteristic and molecular weight as expressed in the B parameter and the lag time. RAGS Part E has determined that dermal exposures contributing less than 10% of oral exposures are insignificant. However, the RSL presents dermal screening levels regardless of contribution percent.

- Effective Predictive Domain (EPD) is an area on a X/Y plot that symbolizes 95% statistical confidence levels of a regression equation to accurately estimate a dermal permeability constant (K_p). Only if a chemical is within the EPD, will the dermal route be calculated. The EPD is determined by investigating the predictive power of a regression equation using MW and $\log K_{ow}$ values for a compound. If the intersection of the values falls within the designated plotted area, the chemical is determined to be in the EPD, and the dermal route is calculated. The boundaries of MW and $\log K_{ow}$ for the regression equation are presented below. The EPD is depicted in RAGS Part E <<https://epa.gov/risk/risk-assessment-guidance-superfund-rags-part-e>> in Appendix A; Exhibit A-1.

- Dermal permeability constant (K_p cm/hr) values are either from EPI Suite <<https://epa.gov/tsca-screening-tools/epi-suite-estimation-program-interface>> or RAGS Part E in the chemical parameter hierarchy. Values from both sources are estimated. Each source has a different estimation model. The RAGS Part E model requires a $\log K_{ow}$ and a MW, and if both $\log K_{ow}$ and MW are available, a K_p is calculated. The RAGS Part E model is taken from the spreadsheet that accompanies RAGS Part E documentation <<https://epa.gov/risk/risk-assessment-guidance-superfund-rags-part-e#docs>> and is reproduced below.

$$K_p = 10^{\log K_p}$$

where:

$$\log K_p = -2.805063 + r^2 \times \log K_{ow} - 0.0056118 \times MW$$

where:

$\log K_p$ = log dermal permeability coefficient of compound in water $\left(\frac{\text{cm}}{\text{hr}}\right)$;

$$r^2 = 0.6645865$$

- Fraction absorbed water (FA) is described in RAGS Part E <<https://epa.gov/risk/risk-assessment-guidance-superfund-rags-part-e>> in Appendix A. The FA term should be applied to account for the loss of chemical due to the desquamation of the outer skin layer and a corresponding reduction in the absorbed dermal dose. To determine FA values for the RSLs, the following regression analysis is performed. This analysis builds on the RAGS Part E data.

- The dimensionless value (B) is the ratio of the permeability coefficient of a compound through the stratum corneum relative to its permeability coefficient across the viable epidermis (ve).

$$B = \frac{K_p \left(\frac{\text{cm}}{\text{hr}} \right)}{K_{p,ve} \left(\frac{\text{cm}}{\text{hr}} \right)} \approx K_p \left(\frac{\text{cm}}{\text{hr}} \right) \times \frac{\sqrt{\text{MW} \left(\frac{\text{g}}{\text{mole}} \right)}}{2.6} \text{ (as an approximation)}$$

where:

$$K_{p,ve} \left(\frac{\text{cm}}{\text{hr}} \right) = \frac{K_{ew} \times D_e \left(\frac{\text{cm}^2}{\text{hr}} \right)}{L_e(\text{cm})}$$

where:

$K_{ew} = 1$ (assuming epidermis behaves essentially as water);

$L_e(\text{cm}) = 10^{-2}(\text{cm})$

$$D_e \left(\frac{\text{cm}^2}{\text{hr}} \right) = \frac{7.1 \times 10^{-6} \left(\frac{\text{cm}^2}{\text{s}} \right)}{\sqrt{\text{MW} \left(\frac{\text{g}}{\text{mole}} \right)}} \left(\text{assumes } D_e = 10^{-6} \left(\frac{\text{cm}^2}{\text{s}} \right) \text{ when MW} = 50 \right)$$

- $t^* = \text{Time to reach steady-state (hours)} = 2.4 \tau_{\text{event}}$

$$\text{If } B \leq 0.6, \text{ then } t^* (\text{hrs}) = 2.4 \times \tau_{\text{event}} \left(\frac{\text{hrs}}{\text{event}} \right)$$

or:

$$\text{If } B > 0.6, \text{ then } t^* (\text{hrs}) = 6 \times \tau_{\text{event}} \left(\frac{\text{hrs}}{\text{event}} \right) \times \left(b - \sqrt{b^2 - c^2} \right)$$

where:

$$b = \frac{2 \times (1 + B)^2}{\pi} - c \text{ and } c = \frac{1 + 3 \times B + 3 \times B^2}{3 \times (1 + B)}$$

- $\tau_{\text{event}} = \text{Lag time per event (hours/event)}$

$$\tau_{\text{event}} \left(\frac{\text{hrs}}{\text{event}} \right) = \frac{I_{\text{sc}}^2 (\text{cm})}{6 \times D_{\text{sc}} \left(\frac{\text{cm}^2}{\text{hr}} \right)}$$

where:

$$\log \frac{D_{\text{sc}} \left(\frac{\text{cm}^2}{\text{hr}} \right)}{I_{\text{sc}}^2 (\text{cm})} = -2.80 - 0.0056 \times \text{MW} \left(\frac{\text{g}}{\text{mole}} \right) \quad \text{or} \quad \frac{D_{\text{sc}} \left(\frac{\text{cm}^2}{\text{hr}} \right)}{I_{\text{sc}}^2 (\text{cm})} = 10^{-2.80 - 0.0056 \times \text{MW} \left(\frac{\text{g}}{\text{mole}} \right)}$$

thus:

$$I_{\text{sc}}^2 (\text{cm}) = \frac{10^{-2.80 - 0.0056 \times \text{MW} \left(\frac{\text{g}}{\text{mole}} \right)}}{D_{\text{sc}} \left(\frac{\text{cm}^2}{\text{hr}} \right)} \quad \text{and} \quad D_{\text{sc}} \left(\frac{\text{cm}^2}{\text{hr}} \right) = I_{\text{sc}}^2 (\text{cm}) \times 10^{-2.80 - 0.0056 \times \text{MW} \left(\frac{\text{g}}{\text{mole}} \right)}$$

4.9.9 Henry's Law constant and Vapor Pressure Determination at Temperature Other Than 25°C

In site-specific mode for soil and soil to groundwater land uses, users are given the option to the change groundwater-soil system temperature from the default of 25°C to a site-specific value. Since the unitless Henry's Law Constant (H') is derived based on the partial pressure of a gas in equilibrium with a liquid and the equilibrium changes when temperature changes, Henry's Law is changed to reflect the equilibrium at the given temperature. The equation below illustrates how H' is derived when groundwater-soil system temperature is changed. An EPA Fact Sheet describing the process can be found at [Henry's Law Constant Fact Sheet](https://epa.gov/vaporintrusion/fact-sheet-correcting-henrys-law-constant-temperature) <<https://epa.gov/vaporintrusion/fact-sheet-correcting-henrys-law-constant-temperature>>.

$$H'T_{gw} (K) = \left(\frac{\exp \left[- \frac{\Delta H_{v,gw} \left(\frac{\text{cal}}{\text{mol}} \right)}{R_c \left(1.9872 \left(\frac{\text{cal}}{\text{mol-k}} \right) \right)} \times \left(\frac{1}{T_{gw} (K)} - \frac{1}{T_R (298.15 K)} \right) \right] \times \text{HLC} \left(\frac{\text{atm-m}^3}{\text{mol}} \right)}{R \left(8.205E-05 \left(\frac{\text{atm-m}^3}{\text{mol-k}} \right) \right) \times T_{gw} (K)} \right)$$

where:

$$T_{gw} (K) = ^\circ\text{C} + 273.15$$

$$\Delta H_{v,gw} \left(\frac{\text{cal}}{\text{mol}} \right) = \Delta H_{v,b} \left(\frac{\text{cal}}{\text{mol}} \right) \times \left[\frac{1 - T_{gw} (K) / T_c (K)}{1 - T_b (K) / T_c (K)} \right]^n$$

where:

$$\text{If } T_b (K) / T_c (K) < 0.57, n = 0.3,$$

$$\text{If } T_b (K) / T_c (K) > 0.71, n = 0.41,$$

$$\text{If } (0.57 < T_b (K) / T_c (K) \leq 0.71), n = (0.74 \times T_b (K) / T_c (K) - 0.116)$$

The equation below illustrates how vapor pressure is derived when groundwater-soil system temperature is changed.

$$VP'_{T_{gw}}(\text{mmHg}) = VP(\text{mmHg}) \times \exp \left[- \frac{\Delta H_{v,gw} \left(\frac{\text{cal}}{\text{mol}} \right)}{R_c \left(1.9872 \left(\frac{\text{cal}}{\text{mol} \cdot \text{K}} \right) \right)} \times \left(\frac{1}{T_{gw}(\text{K})} - \frac{1}{T_R(298.15 \text{ K})} \right) \right]$$

where:

$$T_{gw}(\text{K}) = ^\circ\text{C} + 273.15$$

$$\Delta H_{v,gw} \left(\frac{\text{cal}}{\text{mol}} \right) = \Delta H_{v,b} \left(\frac{\text{cal}}{\text{mol}} \right) \times \left[\frac{1 - T_{gw}(\text{K})/T_c(\text{K})}{1 - T_b(\text{K})/T_c(\text{K})} \right]^n$$

where:

$$\text{If } T_b(\text{K})/T_c(\text{K}) < 0.57, n = 0.3,$$

$$\text{If } T_b(\text{K})/T_c(\text{K}) > 0.71, n = 0.41,$$

$$\text{If } \left(0.57 < T_b(\text{K})/T_c(\text{K}) \leq 0.71 \right), n = \left(0.74 \times T_b(\text{K})/T_c(\text{K}) - 0.116 \right)$$

When changing the groundwater-soil system temperature, the criteria that determines whether a chemical is volatile or not may also change. The Henry's Law constants and vapor pressures that are used in RSL calculations are based on standard laboratory conditions of 25°C. When the groundwater-soil system temperature is changed, the Henry's Law constants and vapor pressures will change accordingly. A volatile chemical at 25°C may not be volatile at a lower temperature. Conversely, a nonvolatile may become volatile at temperatures above 25°C. When the groundwater-soil system temperature is changed the RSL calculator will provide the user with recalculated Henry's Law constants and vapor pressures. These values can be compared to the volatility status requirements presented in section 4.9.4. The RSL calculator does not automatically change the volatility status of a chemical to reflect the user's change of the groundwater-soil system temperature. In site-specific user-provided mode of the calculator, the user may change the volatility status of a chemical if deemed appropriate by the user's regional risk assessor. Changing the volatility status can impact the inclusion of dermal exposure to soil, inhalation of volatiles during household use of water, and the soil to groundwater Method 1 calculations. See section 4.9.4 and 4.8.3 for more information.

5. Special Considerations

Most of the SLs are readily derived by referring to the above equations. However, there are some cases for which the standard equations do not apply and/or external adjustments to the SLs are recommended. These special case chemicals are discussed below.

5.1 Cadmium

"Cadmium (Diet)" is for food and soil use; "Cadmium (Water)" is for water use only. The diet RfD incorporates a 2.5% gastrointestinal absorption (GIABS) adjustment; the water RfD incorporates a 5% GIABS. These GIABS values are used in the RSL calculations to convert oral RfDs to Dermal RfDs, as directed by EPA Risk Assessment Guidance for Superfund (RAGS) Part E, Supplemental Guidance for Dermal Risk Assessment July 2004. Document (PDF)

<<https://semspub.epa.gov/src/document/hq/195>> (186 pp, 4.2 MB) and website <<https://epa.gov/risk/risk-assessment-guidance-superfund-rags-part-e>>.

The RSLs use the chronic MRL from ATSDR as the Cadmium RfD instead of the IRIS value in response to an EPA memo "Recommendations on the Use of Chronic or Subchronic Noncancer Values for Superfund Human Health Risk Assessments

<<https://semspub.epa.gov/work/hq/100002839.pdf>>" released in May 2021; this memo recommends using lower tier toxicity values that are more recent, credible, and relevant than the values that would be automatically selected from the RSL toxicity hierarchy. In this memo, it was recommended that the ATSDR chronic RfD of 1E-04 mg/kg-day from 2012 be used over the IRIS values (5E-04 and 1E-03 mg/kg-day for water and diet, respectively) from 1989. The RSLs have adopted this recommendation and retain the GIABS values from RAGS Part E.

5.2 Lead

EPA has no consensus RfD or SFO for inorganic lead, so it is not possible to calculate SLs using the same methodology used for other chemicals. EPA considers lead to be a special case because of the difficulty in identifying a level of exposure, or dose, below which adverse effects are unlikely, which is needed to develop a RfD.

EPA evaluates lead exposure in residential scenarios by using models such as the Integrated Exposure-Uptake Biokinetic Model (IEUBK) to estimate a blood-lead concentration. Since 1994, the EPA Office of Land and Emergency Management (formerly known as OSWER) has released several directives on risk assessment and screening levels for residential soil lead. The most recent guidance, *Updated Soil Lead Guidance for CERCLA Sites and RCRA Corrective Action Facilities* (2024) <<https://epa.gov/superfund/updated-soil-lead-guidance-cercla-sites-and-rcra-corrective-action-facilities>>, recommends a residential soil lead screening level of 200 mg/kg (ppm) where children

live and play. However, the guidance indicates that for remedial responses, the residential soil screening level should be lowered to 100 mg/kg where there is aggregate exposure and increased risk to children living in communities with multiple sources of lead contamination, such as lead service lines, lead-based paint, or non-attainment areas where the lead concentrations in air exceed the National Ambient Air Quality Standards. A screening level for soil lead at commercial/industrial (non-residential) sites is 800 mg/kg. More information can be found here <<https://epa.gov/superfund/lead-superfund-sites-frequent-questions-risk-assessors-adult-lead-methodology#blood%20level>>, EPA recommends using the EPA Action Level of 15 µg/L in water and the National Ambient Air Quality Standard of 0.15 µg/m³ in air for Screening levels.

EPA uses the Adult Lead Methodology (ALM) model to estimate SLs for an industrial setting. This SL is intended to protect a fetus that may be carried by a pregnant worker. A primary assumption of this methodology is that a screening level that is protective of a fetus will also afford protection for male or female adult workers. The ALM model equations were developed to calculate screening levels such that the fetus of a pregnant worker would not likely have an unsafe concentration of lead in blood.

The default values for absolute bioavailability (ABA) in the IEUBK model for lead in children are 0.3 for soil and dust, and 0.5 for food and water. This corresponds to an RBA for soil of 0.6 (ABA_{soil} / ABA_{water} = 0.6). It's important to note that the ABA values in the IEUBK model are central estimates, and the oral RBA at any given site may be higher or lower than the default oral RBA for lead. For this reason, and because it provides a more comprehensive characterization of exposure at a site, the TRW recommends using EPA SW-846 Method 1340 to estimate the site-specific RBA in soil. Guidance related to these topics can be found in the Soil Bioavailability at Superfund Site Guidance <<https://epa.gov/superfund/soil-bioavailability-superfund-sites-guidance>>.

For more information on EPA's lead models and other lead-related topics, please go to Addressing Lead at Superfund Sites <<https://epa.gov/superfund/lead-superfund-sites>>.

5.3 Manganese

The IRIS RfD (0.14 mg/kg-day) includes manganese from all sources, including diet. The author of the IRIS assessment for manganese recommended that the dietary contribution from the normal U.S. diet (an upper limit of 5 mg/day) be subtracted when evaluating non-food (e.g., drinking water or soil) exposures to manganese, leading to a RfD of 0.071 mg/kg-day for non-food items. The explanatory text in IRIS further recommends using a modifying factor of 3 when calculating risks associated with non-food sources due to a number of uncertainties that are discussed in the IRIS file for manganese, leading to a RfD of 0.024 mg/kg-day. This modified RfD has been used in

the derivation of some manganese screening levels for soil and water. For more information regarding the Manganese RfD, users are advised to contact the author of the IRIS assessment on Manganese.

5.4 Vanadium Compounds

The oral RfD toxicity value for Vanadium, used in this website, is derived from the IRIS oral RfD for Vanadium Pentoxide by factoring out the molecular weight (MW) of the oxide ion. Vanadium Pentoxide (V_2O_5) has a molecular weight of 181.88. The two atoms of Vanadium contribute 56% of the MW. Vanadium Pentoxide's oral RfD of $9E-03$ mg/kg-day multiplied by 56% gives a Vanadium oral RfD of $5.04E-03$ mg/kg-day.

5.5 Uranium

The "Uranium Soluble Salts" RSL uses the ATSDR intermediate MRL of $2E-04$ mg/kg-day instead of the IRIS oral RfD of $3E-03$ mg/kg-day. This is a deviation from the typical RSL toxicity hierarchy. This deviation was justified by the 2003 hierarchy memo (PDF) <https://semspub.epa.gov/src/document/hq/136> (4 pp, 25 K) that acknowledges and "recognizes that EPA should use the best science available on which to base risk assessments." In December 2016, the EPA Office of Superfund Remediation and Technology Innovation (OSRTI) announced its determination that the ATSDR intermediate MRL generally reflects a better scientific basis for assessing the chronic health risks of soluble uranium than the RfD currently available in IRIS." The rationale for this determination is summarized in an accompanying memorandum (PDF) <https://semspub.epa.gov/src/document/hq/196808> (11 pp, 2.5 MB), which recommends use of the ATSDR intermediate MRL for assessing chronic and subchronic human exposures at Superfund sites nationwide.

5.6 Chromium (VI)

It is recommended that valence-specific data for chromium be collected whenever possible when chromium is likely to be an important contaminant at a site, and when hexavalent chromium (Cr(VI)) may exist. For Cr(VI), IRIS shows an air inhalation unit risk (IUR) of $1.2E-2$ per ($\mu\text{g}/\text{m}^3$). While the exact ratio of Cr(VI) to Cr(III) in the data used to derive the IRIS IUR value is not known, it is likely that both Cr(VI) and Cr(III) were present. The RSLs, calculated using the IRIS IUR, assume that the Cr(VI) to Cr(III) ratio is 1:6. Because of various sources of uncertainty, this assumption may overestimate or underestimate the risk calculated. Users are invited to review the document "Toxicological Review of Hexavalent Chromium" in support of the summary information on Cr(VI) on IRIS to determine whether they believe this ratio applies to their site and to consider consulting with an EPA regional risk assessor. The uncertainty section of the risk assessment may

want to address the potential for overestimating or underestimating the risk and provide quantitative analysis by deriving different IUR values based on different Cr(VI) to Cr(III) ratios from more recent studies.

In the RSL Table, the Cr(VI) specific value (assuming 100% Cr(VI)) is derived by multiplying the IRIS Cr(VI) value by 7. This is considered to be a health-protective assumption, and is also consistent with the State of California's interpretation of the Mancuso study that forms the basis for their estimated cancer potency of Cr(VI).

If you are working on a chromium site, you may want to contact the appropriate regulatory officials in your region to determine what their position is on this issue.

The Maximum Contaminant Level (MCL) of 100 µg/L for "Chromium (total)", from the EPA's MCL <<https://epa.gov/ground-water-and-drinking-water/national-primary-drinking-water-regulations>> listing is applied to the "Chromium, Total" analyte on this website.

The State of California Environmental Protection Agency (CalEPA) determined that Cr(VI) by ingestion is likely to be carcinogenic in humans. CalEPA derived an oral cancer slope factor, based on a dose-related increase of tumors of the small intestine in male mice conducted by the National Toxicology Program (PDF) [🔗](https://ntp.niehs.nih.gov/results/areas/hexchrom/index.html) <<https://ntp.niehs.nih.gov/results/areas/hexchrom/index.html>> (162 pp, 1.9 MB). CalEPA determined that Cr(VI) was carcinogenic by mutagenic by mode of action.

EPA's Office of Pesticide Programs (OPP) made a determination that Cr(VI) has a mutagenic mode of action for carcinogenesis in all cells regardless of type, following administration via drinking water. OPP recommended that Age-Dependent Adjustment Factors (ADAFs) be applied when assessing cancer risks from early-life exposure (< 16 years of age). This determination was reviewed by OPP's Cancer Assessment Review Committee and published in a peer review journal (PDF) <<https://semspub.epa.gov/src/document/03/2218729>>(23 pp, 414 K).

Therefore, the RSL workgroup adopted the Tier III CalEPA value and the OPP recommendation with respect to mutagenicity. More recently, in 2011, external peer reviewers provided input on the EPA's Office of Research and Development Integrated Risk Information System draft Toxicological Review of Hexavalent Chromium <<https://iris.epa.gov/document/&deid=221433>>. The majority of reviewers questioned the evidence used to support a mutagenic mode of action for carcinogenesis for Cr(VI). Furthermore, in 2011 California Environmental Protection Agency finalized its drinking water Public Health Goal for Cr(VI). CalEPA's Technical Support Document [🔗](https://www.oehha.ca.gov/water/phg/072911cr6phg.html) <<https://www.oehha.ca.gov/water/phg/072911cr6phg.html>> concluded in numerous studies that Cr(VI) is both genotoxic and mutagenic.

Therefore, the RSL workgroup acknowledges that there is uncertainty associated with the assessment of hexavalent chromium. However, no updated consensus IRIS assessment (Tier I) has yet appeared, and chromium is still under review by the IRIS program. With respect to RSLs, the more health-protective approach of applying ADAFs for early life exposure via ingestion, dermal and inhalation was used to calculate screening levels for all exposure pathways. Application of ADAFs for all exposure pathways results in more health-protective screening levels.

As always, consult EPA toxicologists in the Superfund program of the regional office when developing site-specific screening levels.

5.7 Aminodinitrotoluenes

The IRIS oral RfD of 2E-03 mg/kg-day for 2,4-Dinitrotoluene is no longer used as a surrogate for 2-Amino-4,6-Dinitrotoluene and 4-Amino-2,6-Dinitrotoluene. Appendix screening values from a new PPRTV assessment are being used instead.

5.8 PCBs and Aroclors

In the RSL Tables, the chemical group, "Polychlorinated Biphenyls (PCBs)," has three distinct types of PCBs listed: Aroclors, individual PCB congeners, and risk/persistence-based PCBs. The PCB congeners are evaluated as dioxin-like, using dioxin TEFs, as discussed in section 2.3. The risk/persistence-based PCB toxicity values come from the IRIS summary <https://iris.epa.gov/static/pdfs/0294_summary.pdf>. In that summary, high, low, and lowest risk and persistence human oral slope factor tiers are given. Below is the RSL interpretation of this information and is represented in the RSL tables and calculator.

TIERS OF HUMAN ORAL SLOPE FACTORS FOR ENVIRONMENTAL PCBs			
Media	High	Low	Lowest
Food	Yes	No	No
Soil	Yes	No	No
Sediment	Yes	No	No
Tapwater	No	Yes	No
Surface Water	No	Yes	No
Air	Yes	Yes	Yes

The IRIS Profile offers various criteria for the assignment of Aroclors into risk/persistence tiers. When congeners with more than four chlorines comprise less than one-half of a percent of total PCBs, the lowest risk/persistence tier is appropriate. Aroclor 1016 has virtually no congeners with more than four chlorines and is assigned to the lowest risk/persistence tier (EPA 1996

<[https://epa.gov/sites/production/files/2015-10/documents/pcbs_cancer_dose-](https://epa.gov/sites/production/files/2015-10/documents/pcbs_cancer_dose-response_assessment_and_application_to_environmental_mixtures.pdf)

response_assessment_and_application_to_environmental_mixtures.pdf>). (Chlorination data and other physicochemical parameters can be found in section 4 of the ATSDR Profile [\[\]](https://www.atsdr.cdc.gov/toxprofiles/tp17.pdf)

<<https://www.atsdr.cdc.gov/toxprofiles/tp17.pdf>>.) Most of the criteria for assignment to the high risk/persistence tier are met by the other Aroclors on the RSL Table as they are typically assessed at environmental sites. In addition to the degree of chlorination, these criteria include: food chain exposure; sediment or soil ingestion; dust or aerosol inhalation; dermal exposure; presence of dioxin-like, tumor-promoting, or persistent congeners; and early-life exposure (all pathways and mixtures). These are default recommendations for purposes of RSL screening. Below represents the assignment of Aroclors to risk/persistence tiers for the RSL tables.

TIERS OF HUMAN ORAL SLOPE FACTORS FOR ENVIRONMENTAL PCBs			
Aroclor	High	Low	Lowest
1016	No	No	Yes
1221	Yes	No	No
1232	Yes	No	No
1242	Yes	No	No
1248	Yes	No	No
1254	Yes	No	No
1260	Yes	No	No

Aroclor 5460 toxicity is determined in a PPRTV <<https://cfpub.epa.gov/ncea/pprtv/documents/aroclor5460.pdf>> independently from the IRIS assessment.

If risk assessors believe that the form of PCB and the environmental route at a specific site warrant a different assignment of risk/persistence category, they may consult with regional risk assessors on site-specific cases.

5.9 Xylenes

The IRIS oral RfD of 2E-01 mg/kg-day for xylene, mixture is used as a surrogate for the 3 xylene congeners. The earlier RfD values for some xylene isomers were withdrawn from our electronic version of HEAST. Also, the IRIS inhalation RfC of 1E-01 mg/m³ for xylene, mixture is used as a surrogate for the 3 xylene congeners.

5.10 Arsenic

Arsenic screening levels for ingestion of soil and sediment are now calculated with the default relative bioavailability factor <<https://epa.gov/superfund/soil-bioavailability-superfund-sites-guidance>> (RBA) of 0.6. The RBA can be adjusted using the calculator in site-specific/user-provided mode the same way toxicity values can be changed. The RBA for soil ingestion is shown in the calculator output. The 2012 document, *Compilation and Review of Data on Relative Bioavailability of Arsenic in Soil* (PDF) <<https://semspub.epa.gov/src/document/hq/175339>> (58 pp, 474 K) provides supporting information.

In 2017, the EPA has released a standard operating procedure for an in vitro bioaccessibility assay for arsenic in soil. The in vitro method for predicting oral RBA of arsenic in soil (EPA SW846 Method 1340) has been validated, and it is now recommended that the in vitro method be used to estimate site-specific RBA, when site-specific RBA is needed. This method can provide a more comprehensive characterization of RBA variability at the site. The default value represents the 95th percentile of many arsenic soil samples, and it is expected that the site-specific RBA will be less than 0.6 at most sites, which means that the default should be protective for screening. This method may also be used for sediments where the incidental ingestion of sediments is being assessed. Site-specific RBAs derived with the in vitro method should be verified with your Regional Risk Assessor. Guidance related to these topics can be found in the *Soil Bioavailability at Superfund Sites: Guidance* <<https://epa.gov/superfund/soil-bioavailability-superfund-sites-guidance>>.

Absolute bioavailability can be thought of as the absorption fraction (PDF) <<https://semspub.epa.gov/src/document/hq/175333>> (20 pp, 133 K). Relative bioavailability accounts for differences in the bioavailability of a contaminant between the medium of exposure (e.g., soil) and the media associated with the toxicity value (e.g., the arsenic RfD and SFO are derived from drinking water studies). The 60% oral RBA for arsenic in soil is empirically-based. It represents an upper-bound estimate from numerous studies where the oral RBA of soil-borne arsenic in samples collected from across the U.S. was experimentally determined against the water-soluble form. This RBA does not apply to dermal exposures to arsenic in soil for which the absorbed dose is calculated using a dermal absorption fraction (ABS_d) of 0.03 (Exhibit 3-4 of USEPA, 2004).

5.11 Total Petroleum Hydrocarbons (TPHs)

Traditionally, hydrocarbon-impacted soils at sites contaminated by releases of petroleum fuels have been managed based on their total petroleum hydrocarbon (TPH) content. TPH refers to the total mass of hydrocarbons present without identifying individual compounds. In practice, TPH is defined by the analytical method that is used to measure the hydrocarbon content in contaminated media. Since the hydrocarbon extraction efficiency is not identical for each method, the same sample analyzed by different TPH methods will produce different TPH concentrations.

The hazard and health risk assessments that are typically conducted to support risk management decisions at contaminated sites generally require some level of understanding of the hydrocarbon chemical composition present in the contaminated media. Traditional TPH measurement techniques, however, provide no specific information about the detected hydrocarbons. Because TPH is not a consistent entity, the assessment of health effects and development of toxicity values for mixtures of hydrocarbons are problematic. In fact, many risk assessors prefer to analyze and assess the individual chemical constituents rather than rely on TPH data; consult with your regional risk assessor for site-specific recommendations. In cases where TPH data are used, more details about the provisional TPH toxicity values are provided below.

In 2022, the Superfund Health Risk Technical Support Center National Center for Environmental Assessment Office of Research and Development published a document that provides the data, methods, and assumptions for deriving Provisional Peer-Reviewed Toxicity Values (PPRTVs <<https://epa.gov/pprtv/provisional-peer-reviewed-toxicity-values-pprtvs-assessments>>) for six fractions of petroleum hydrocarbons. The six TPH fractions were assigned representative compounds for determination of toxicity values and chemical-specific parameters to calculate RSLs.

The PPRTV paper was the principal source for the derivation of these values. The carbon ranges and representative compounds for the RfDs, RfCs, and chemical-specific parameters are listed in the table below. An average of the chemical-specific parameters for 1,3,5-trimethylbenzene, 1,2,4-trimethylbenzene, and 1,2,3-trimethylbenzene was calculated for the medium aromatic fraction. This is because all three are representative compounds for chronic and subchronic RfDs and RfCs. An average of the chemical-specific parameters for n-heptane, n-hexane, and cyclohexene was calculated for the low aliphatic fraction. This is because n-heptane represents the chronic RfC, n-hexane represents the subchronic RfC, and cyclohexene represents the the chronic and subchronic RfDs.

The carbon ranges, presented in the PPRTV assessment, may not exactly match the carbon ranges from laboratory results for TPH fractions. Additionally, the carbon ranges, presented in the PPPRTV assessment, may not match laboratory results for DRO, GRO, ORO, or RRO analysis. The TPH carbon ranges used in the RSLs are not intended to screen against DRO, GRO, ORO and RRO analysis. While the carbon ranges for TPHs and range organics may not exactly match, with direction from your regional risk assessor, reasonable assignment may be achieved.

TPH Fractions	Number of Carbons	Equivalent Carbon Number Index	Representative Compound (RfD/RfC)	Representative Compound (Chemical Parameters)
Low aliphatic	C5-C8	EC5-EC8	cyclohexene/n-heptane and n-hexane	average of cyclohexene, n-heptane, and n-hexane
Medium aliphatic	C9-C18	EC>8-EC16	midrange aliphatic hydrocarbon streams	n-nonane*
High aliphatic	C19-C32	EC>16-EC35	white mineral oil	white mineral oil
Low aromatic	C6-C8	EC6-EC<9	benzene	benzene
Medium aromatic	C9-C10	EC9-EC<11	1,3,5-trimethylbenzene, 1,2,4-trimethylbenzene, and 1,2,3-trimethylbenzene	average of 1,3,5-trimethylbenzene, 1,2,4-trimethylbenzene, and 1,2,3-trimethylbenzene
High aromatic	C10-C32	EC>11-EC35	benzo[a]pyrene	benzo[a]pyrene

*A medium aliphatic representative compound was not listed in the PPRTV paper so n-nonane was selected by the RSL work-group to represent the chemical-specific parameters.

Within the Superfund program, when TPHs are considered in the site characterization, they are assessed in supplemental health risk assessments only for potential noncancer health effects. Therefore, starting with the May 2014 update the RSLs are no longer calculated using cancer toxicity values. Most of the carcinogens in the TPH carbon range are individually listed on the RSL table. Combining TPH and individual constituent cancer risks would be overly protective.

5.12 Soil Saturation Limit (C_{sat})

The soil saturation concentration, C_{sat} , corresponds to the contaminant concentration in soil at which the absorptive limits of the soil particles, the solubility limits of the soil pore water, and saturation of soil pore air have been reached. Above this concentration, the soil contaminant may be present in free phase (i.e., nonaqueous phase liquids (NAPLs) for contaminants that are liquid at ambient soil temperatures and pure solid phases for compounds that are solid at ambient soil temperatures). C_{sat} is not calculated for chemicals that are solid at ambient soil temperatures. The following decision criteria was established from SSL guidance, Table C-3: if melting point is less than 20 °C, chemical is a liquid; if melting point is above 20 °C, chemical is solid.

Equation 4-10 is used to calculate C_{sat} for each volatile contaminant. As an update to RAGS HHEM, Part B (USEPA 1991a), this equation takes into account the amount of contaminant that is in the vapor phase in soil in addition to the amount dissolved in the soil's pore water and sorbed to soil particles. If H' is not available, C_{sat} can still be calculated.

Chemical-specific C_{sat} concentrations must be compared with each VF-based inhalation SL because a basic principle of the SL volatilization model is not applicable when free-phase contaminants are present. How these cases are handled depends on whether the contaminant is liquid or solid at ambient temperatures. Liquid contaminants that have a VF-based inhalation SL that exceeds the C_{sat} concentration are set equal to C_{sat} . For organic compounds that are solids (e.g., PAHs), soil screening decisions are based on the appropriate SLs for other pathways of concern at the site (e.g., ingestion). Note, that the SLs presented for soil inhalation in the RSL tool combine the VF and the PEF components. If the C_{sat} substitution is performed, the whole SL is replaced and not just the VF component.

The RSL tables and the default calculator settings do not substitute C_{sat} for risk-based calculations. If the risk-based concentration exceeds C_{sat} , the resulting SSL concentration may be overly protective. This is because the dissolved, absorbed and vapor concentrations cease to rise linearly as soil concentration increases above the C_{sat} level (pure product or nonaqueous phase liquid (NAPL) is present). The SSL model used in the RSL calculator is not a four phase model. If a NAPL is present at your site more sophisticated models may be necessary. The calculator, if

operated in site-specific mode, will give the option to apply the C_{sat} substitution rule. H' changes when groundwater temperature changes. Please see section 4.9.9 of this user guide for H' determination at temperature other than 25°C.

$$C_{\text{sat}} \left(\frac{\text{mg}}{\text{kg}} \right) = \frac{S \left(\frac{\text{mg}}{\text{L}} \right)}{\rho_b \left(\frac{\text{kg}}{\text{L}} \right)} \times \left(K_d \left(\frac{\text{L}}{\text{kg}} \right) \times \rho_b \left(\frac{\text{kg}}{\text{L}} \right) + \theta_w \left(\frac{0.15 L_{\text{water}}}{L_{\text{soil}}} \right) + H' \times \theta_a \left(\frac{L_{\text{air}}}{L_{\text{soil}}} \right) \right)$$

where:

$$K_d \left(\frac{\text{L}}{\text{kg}} \right) = f_{\text{oc}} \left(\frac{0.006 \text{ g-carbon}}{\text{g-soil}} \right) \times K_{\text{oc}} \left(\frac{\text{L}}{\text{kg}} \right), \text{ for organic compounds;}$$

$K_d \left(\frac{\text{L}}{\text{kg}} \right)$ values for inorganic compounds are listed in the user guide.

$$\theta_a \left(\frac{L_{\text{air}}}{L_{\text{soil}}} \right) = n \left(\frac{L_{\text{pore}}}{L_{\text{soil}}} \right) - \theta_w \left(\frac{0.15 L_{\text{water}}}{L_{\text{soil}}} \right) \text{ and: } n \left(\frac{L_{\text{pore}}}{L_{\text{soil}}} \right) = 1 - \frac{\rho_b \left(\frac{\text{kg}}{\text{L}} \right)}{\rho_s \left(\frac{\text{kg}}{\text{L}} \right)}$$

5.13 SL Theoretical Ceiling Limit

The ceiling limit of 10^{+5} mg/kg is equivalent to a chemical representing 10% by weight of the soil sample. At this contaminant concentration (and higher), the assumptions for soil contact may be violated (for example, soil adherence and wind-borne dispersion assumptions) due to the presence of the foreign substance itself.

The RSL tables and the default calculator settings do not substitute the theoretical ceiling limit for risk-based calculations but they do indicate if the resulting RSL has exceeded the theoretical ceiling limit in the key. The calculator, if operated in site-specific mode, will give the option to apply the theoretical ceiling limit.

5.14 Target Risk

With the exceptions described previously, SLs are chemical concentrations that correspond to fixed levels of risk (i.e., either a one-in-one million [10^{-6}] for cancer risk or a noncarcinogenic hazard quotient of 1) in soil, air, and water. In noncarcinogenic equations, THQ represents the target hazard quotient and is used for individual substances or exposure routes like: ingestion, dermal, and inhalation. The target hazard index (THI), is the target across multiple substances or exposure routes. In most cases, where a substance causes both cancer and noncancer (systemic) effects, the 10^{-6} cancer risk will result in a more stringent criteria and consequently this value is

presented in the printed copy of the Table. SL concentrations that equate to a 10^{-6} cancer risk are indicated by 'ca' in the calculator and 'c' in the generic tables. SL concentrations that equate to a hazard quotient (HQ) of 1 for noncarcinogenic concerns are indicated by 'nc' in the calculator and 'n' in the generic tables.

If the SLs are to be used for site screening, it is recommended that both cancer and noncancer-based SLs be used. Both carcinogenic and noncarcinogenic values may be obtained in the Supporting Tables.

Some users of this SL Table may plan to multiply the cancer SL concentrations by 10 or 100 to set 'action levels' for triggering remediation or to set less stringent cleanup levels for a specific site after considering non-risk-based factors such as ambient levels, detection limits, or technological feasibility. This risk management practice recognizes that there may be a range of values that may be 'acceptable' for carcinogenic risk (EPA's risk management range is one-in-a-million [10^{-6}] to one-in-ten thousand [10^{-4}]). However, this practice could lead one to overlook serious noncancer health threats and it is strongly recommended that the user consult with a toxicologist or regional risk assessor before doing this. Carcinogens are indicated by an asterisk (*) in the SL Table where the noncancer SLs would be exceeded if the cancer value that is displayed is multiplied by 100. (***) indicate that the noncancer values would be exceeded if the cancer SL were multiplied by 10. There is no range of 'acceptable' noncarcinogenic 'risk' for CERCLA sites. Therefore, the noncancer SLs should not be multiplied by 10 or 100 when setting final cleanup criteria. In the rare case where noncancer SLs are more stringent than cancer SLs set at one-in-one-million risk, a similar approach has been applied (e.g. 'max').

SL concentrations in the printed Table are risk-based, but for soil there are two important exceptions: (1) for several volatile chemicals, SLs may exceed the soil saturation level ('sat') and (2) SLs may exceed a non-risk based 'ceiling limit' concentration of 10^{+5} mg/kg ('max') for relatively less toxic inorganic and semivolatile contaminants. For more information on the 'sat' value in the SL Table, please see the discussion in Section 5.11. For more information on the 'max' value in the SL Table, please see the discussion in Section 5.13.

With respect to applying a 'ceiling limit' for chemicals other than volatiles, it is recognized that this is not a universally accepted approach. Some within the agency argue that all values should be risk-based to allow for scaling (for example, if the risk-based SL is set at a hazard quotient = 1.0, and the user would like to set the hazard quotient to 0.1 to take into account multiple chemicals, then this is as simple as multiplying the risk-based SL by 1/10th). If scaling is necessary, SL users can do this simply by referring to the Supporting Tables at this website where risk-based soil concentrations are presented for all chemicals.

In spite of the fact that applying a ceiling limit is not a universally accepted approach, this table applies a 'max' soil concentration to the SL Table for the following reasons:

- Risk-based SLs for some chemicals in soil exceed unity (>1,000,000 mg/kg), which is not possible.
- The ceiling limit of 10^{+5} mg/kg is equivalent to a chemical representing 10% by weight of the soil sample. At this contaminant concentration (and higher), the assumptions for soil contact may be violated (for example, soil adherence and wind-borne dispersion assumptions) due to the presence of the foreign substance itself.
- SLs currently do not address short-term exposures (e.g., pica children and construction workers). Although extremely high soil SLs are likely to represent relatively non-toxic chemicals, such high values may not be justified if in fact more toxicological data were available for evaluating short-term and/or acute exposures.

5.15 Screening Sites with Multiple Contaminants

Users needing to screen sites with multiple contaminants should consult with their regional risk assessors. See the Frequent Questions <<https://epa.gov/risk/regional-screening-levels-frequent-questions>> page for information on use of the THQ=1.0 versus the THQ=0.1 tables.

5.16 Deriving Soil Gas SLs

The air SLs could apply to indoor air from, e.g., a vapor intrusion scenario. To model indoor air concentrations from other media (e.g., soil gas, groundwater), consult with regional experts in vapor intrusion.

For more information on EPA's current understanding of this emerging exposure pathway, please refer to EPA's recent draft guidance Evaluating the Vapor Intrusion to Indoor Air Pathway from Groundwater and Soils (Subsurface Vapor Intrusion Guidance) (USEPA 2002)

<<https://epa.gov/vaporintrusion/vapor-intrusion-resources>>.

5.17 Mutagens

Some of the cancer causing analytes in this tool operate by a mutagenic mode of action for carcinogenesis. There is reason to surmise that some chemicals with a mutagenic mode of action, which would be expected to cause irreversible changes to DNA, would exhibit a greater effect in early-life versus later-life exposure. Cancer risk to children in the context of the U.S. Environmental Protection Agency's cancer guidelines (U.S. EPA, 2005 (PDF)

<<https://semspub.epa.gov/src/document/hq/190690>> (166 pp, 468 K)) includes both early-life exposures that

may result in the occurrence of cancer during childhood and early-life exposures that may contribute to cancers later in life. In keeping with this guidance, separate cancer risk equations are presented for mutagens. The mutagen vinyl chloride has a unique set of equations. The IRIS profile <<https://iris.epa.gov/static/pdfs/1001tr.pdf>> should be consulted for the intent of non-prorated early life exposure combined with prorating continuous life exposure. Consult Supplemental Guidance for Assessing Susceptibility from Early-Life Exposure to Carcinogens, EPA/630/R-03/003F, March 2005 (PDF) <https://epa.gov/sites/production/files/2013-09/documents/childrens_supplement_final.pdf> (126 pp, 1.78 MB) for further information on mutagens.

The below table lists the chemicals considered to be carcinogenic by mutagenic mode of action for the purposes of the RSLs. Also provided in the table is a link to the source as to why the chemical is considered to be a mutagen.

Chemical	CASRN	Reference
Acrylamide	79-06-1	IRIS < https://iris.epa.gov/chemicallanding/&substance_nmbr=286 >
Benz[a]anthracene	56-55-3	Benzo[a]pyrene*
Benzidine	92-87-5	Supplemental Guidance < https://epa.gov/sites/production/files/2013-09/documents/childrens_supplement_final.pdf >
Benzo[a]pyrene	50-32-8	Supplemental Guidance < https://epa.gov/sites/production/files/2013-09/documents/childrens_supplement_final.pdf >
Benzo[b]fluoranthene	205-99-2	Benzo[a]pyrene*
Benzo[k]fluoranthene	207-08-9	Benzo[a]pyrene*
Chromium(VI)	18540-29-9	CalEPA  < https://oehha.ca.gov/chemicals/chromium-hexavalent > and IRIS < https://iris.epa.gov/chemicallanding/&substance_nmbr=144 >
Chrysene	218-01-9	Benzo[a]pyrene*

Coke Oven Emissions	8007-45-2	70 Federal Register 1992 🔗 < https://www.federalregister.gov/documents/2005/04/15/05-6942/national-emission-standards-for-coke-oven-batteries >
Dibenz[a,h]anthracene	53-70-3	Supplemental Guidance < https://epa.gov/sites/production/files/2013-09/documents/childrens_supplement_final.pdf >
Dibromo-3-chloropropane, 1,2-	96-12-8	PPRTV
Dimethylbenz(a)anthracene, 7,12-	57-97-6	Supplemental Guidance < https://epa.gov/sites/production/files/2013-09/documents/childrens_supplement_final.pdf >
Ethylene Oxide	75-21-8	IRIS < https://iris.epa.gov/chemicallanding/&substance_nmbr=1025 >
Indeno[1,2,3-cd]pyrene	193-39-5	Benzo[a]pyrene*
Methylcholanthrene, 3-	56-49-5	Supplemental Guidance < https://epa.gov/sites/production/files/2013-09/documents/childrens_supplement_final.pdf >
Methylene Chloride	75-09-2	IRIS < https://iris.epa.gov/chemicallanding/&substance_nmbr=70 >
Methylene-bis(2-chloroaniline), 4,4'-	101-14-4	PPRTV < https://iris.epa.gov/document/&deid=338996 >
Nitrosodiethylamine, N-	55-18-5	Supplemental Guidance < https://epa.gov/sites/production/files/2013-09/documents/childrens_supplement_final.pdf >
Nitrosodimethylamine, N-	62-75-9	Supplemental Guidance < https://epa.gov/sites/production/files/2013-09/documents/childrens_supplement_final.pdf >
Nitroso-N-ethylurea, N-	759-73-9	Supplemental Guidance < https://epa.gov/sites/production/files/2013-09/documents/childrens_supplement_final.pdf >

Nitroso-N-methylurea, N-	684-93-5	Supplemental Guidance < https://epa.gov/sites/production/files/2013-09/documents/childrens_supplement_final.pdf >
Safrole	94-59-7	Supplemental Guidance < https://epa.gov/sites/production/files/2013-09/documents/childrens_supplement_final.pdf >
Trichloroethylene	79-01-6	IRIS < https://iris.epa.gov/chemicallanding/&substance_nmbr=199 >
Trichloropropane, 1,2,3-	96-18-4	IRIS < https://iris.epa.gov/chemicallanding/&substance_nmbr=200 >
Urethane	51-79-6	Supplemental Guidance < https://epa.gov/sites/production/files/2013-09/documents/childrens_supplement_final.pdf >
Vinyl Chloride	75-01-4	Supplemental Guidance < https://epa.gov/sites/production/files/2013-09/documents/childrens_supplement_final.pdf >

* Please see section 2.3.6 of this user guide regarding Relative Potency Factors (RPFs).

5.18 Trichloroethylene (TCE)

It is recommended that a regional risk assessor be consulted when evaluating TCE in any medium especially when less than chronic exposure scenarios are considered. The Superfund <<https://epa.gov/superfund>> program issued a Compilation of Information Relating of Early/Interim Actions at Superfund Sites and the TCE IRIS Assessment (PDF) <<https://semspub.epa.gov/src/document/hq/174044>> (3 pp, 929 K) memo in August 2014. Several regions have issued their own guidance as well.

In order to make the calculator display the correct results for TCE, the standard cancer and mutagen equations needed to be combined. Since TCE requires the use of different toxicity values for cancer and mutagen equations, it was decided to make a toxicity value adjustment factor for cancer (CAF) and mutagens (MAF). The adjustments were done for oral (o) and inhalation (i). These adjustment factors are used in the TCE equation images presented in section 4. The equations used are presented below. The adjustment factors are based on the adult-based toxicity values and these are the cancer toxicity values presented in the Generic Tables.

$$\text{CAF}_o(0.804) = \frac{\text{CSF}_o \left(\frac{3.7 \times 10^{-2} \text{ mg}}{\text{kg-day}} \right)^{-1} \text{ NHL + Liver Oral Slope Factor}}{\text{CSF}_o \left(\frac{4.6 \times 10^{-2} \text{ mg}}{\text{kg-day}} \right)^{-1} \text{ Adult - Based Oral Slope Factor}} ; \text{MAF}_o(0.202) = \frac{\text{CSF}_o \left(\frac{9.3 \times 10^{-3} \text{ mg}}{\text{kg-day}} \right)^{-1} \text{ Kidney Oral Slope Factor}}{\text{CSF}_o \left(\frac{4.6 \times 10^{-2} \text{ mg}}{\text{kg-day}} \right)^{-1} \text{ Adult - Based Oral Slope Factor}}$$

$$\text{CAF}_i(0.756) = \frac{\text{IUR} \left(\frac{3.1 \times 10^{-6} \text{ } \mu\text{g}}{\text{kg-day}} \right)^{-1} \text{ NHL + Liver Unit Risk Estimate}}{\text{IUR} \left(\frac{4.1 \times 10^{-6} \text{ } \mu\text{g}}{\text{kg-day}} \right)^{-1} \text{ Adult - Based Unit Risk Estimate}} ; \text{MAF}_i(0.244) = \frac{\text{IUR} \left(\frac{1.0 \times 10^{-6} \text{ } \mu\text{g}}{\text{kg-day}} \right)^{-1} \text{ Kidney Unit Risk Estimate}}{\text{IUR} \left(\frac{4.1 \times 10^{-6} \text{ } \mu\text{g}}{\text{kg-day}} \right)^{-1} \text{ Adult - Based Unit Risk Estimate}}$$

5.19 Mercuric Chloride (and other Mercury salts)

The IRIS RfC for "Mercury (elemental)" is used as a surrogate for "Mercuric Chloride (and other Mercury salts)". Note, that the VF for "Mercury (elemental)" is not used as a surrogate for "Mercuric Chloride (and other Mercury salts)". The use of the surrogate RfC would appear to be a violation of the RSL toxicity hierarchy because Cal EPA offers a RfC for Mercuric Chloride. However, the actual form of mercury evaluated for the Cal EPA RfC was elemental mercury. Since IRIS already had a RfC for "Mercury (elemental)", it was decided to use the tier 1 source over a tier 3 source.

5.20 Cyanide (CN⁻)

The IRIS RfC for "Hydrogen Cyanide" is used as a surrogate for "Cyanide (CN⁻)".

5.21 Thallic Oxide and Thallium Selenite

The oral RfD for thallic oxide, used in this website, is derived from the PPRTV oral RfD for thallium sulfate by molecular weight (MW) adjustments and stoichiometric calculations. Thallic oxide (Tl₂O₃) has a MW of 456.765 and thallium sulfate (Tl₂SO₄) has a MW of 504.82. To derive the oral RfD of 2E-05 mg/kg-day for thallic oxide, the thallium sulfate RfD of 2E-05 mg/kg-day is multiplied by the MW of thallic oxide (456.765) divided by the MW of thallium sulfate (504.82). The oral RfD for thallium selenite, used in this website, is derived from the PPRTV oral RfD for thallium by molecular weight (MW) adjustments and stoichiometric calculations. Thallium selenite (TlSe) has a MW of 283.34 and thallium (Tl) has a MW of 204.38. To derive the oral RfD of 1E-05 mg/kg-day for thallium selenite, the thallium RfD of 1E-05 mg/kg-day is multiplied by the MW of thallium selenite (283.34) divided by the MW of thallium (204.38).

5.22 Polycyclic Aromatic Hydrocarbons (PAHs)

For PAHs in soil, we have not made any recommendations on a default value, which is to say that the default assumption remains that these are 100% bioavailable. There is also no available in vitro method to estimate the oral RBA of PAHs. A small number of sites have elected to run swine

or rat models to assess oral RBA, and the TRW has reviewed them before the RBA was accepted for use at the site. Guidance related to these topics can be found in the Soil Bioavailability at Superfund Sites Guidance <<https://epa.gov/superfund/soil-bioavailability-superfund-sites-guidance>>.

5.23 Refractory Ceramic Fibers (units in fibers)

The ATSDR ☑ chronic RfC for refractory ceramic fibers is presented in units of fibers/cm³ (0.03 fibers/cm³). The RfC presented in the RSL tables and calculator is converted to units of fibers/m³ (3E+04 fibers/m³), to be consistent with all other chemicals where the RfC unit is mg/m³. When the chronic RfC is used in the standard RSL air inhalation equations, the resulting units are not in µg/m³ like all the other chemicals, rather the units are in fibers/m³. RSLs are only calculated for air as the medium. The air values in the RSL table are calculated using the equations below to give RSLs in fibers/m³.

Resident Air Noncancer Equation

$$SL_{\text{res-air-inhrfc}} \left(\frac{\text{f}}{\text{m}^3} \right) = \frac{\text{THQ} \times \text{AT}_{\text{res-a}} \left(\frac{365 \text{ days}}{\text{yr}} \times \text{ED}_{\text{res}} (26 \text{ yr}) \right)}{\left(\frac{1}{\text{RfC} \left(\frac{\text{f}}{\text{m}^3} \right)} \right) \times \text{EF}_{\text{res}} \left(\frac{350 \text{ days}}{\text{yr}} \right) \times \text{ED}_{\text{res}} (26 \text{ yr}) \times \text{ET}_{\text{res}} \left(\frac{24 \text{ hrs}}{\text{day}} \right) \times \left(\frac{1 \text{ day}}{24 \text{ hrs}} \right)}$$

Composite Worker Air Noncancer Equation

$$SL_{\text{com-air-inhrfc}} \left(\frac{\text{f}}{\text{m}^3} \right) = \frac{\text{THQ} \times \text{AT}_{\text{com-a}} \left(\frac{365 \text{ days}}{\text{yr}} \times \text{ED}_{\text{com}} (25 \text{ yr}) \right)}{\left(\frac{1}{\text{RfC} \left(\frac{\text{f}}{\text{m}^3} \right)} \right) \times \text{EF}_{\text{com}} \left(\frac{250 \text{ days}}{\text{yr}} \right) \times \text{ED}_{\text{com}} (25 \text{ yr}) \times \text{ET}_{\text{com}} \left(\frac{8 \text{ hrs}}{\text{day}} \right) \times \left(\frac{1 \text{ day}}{24 \text{ hrs}} \right)}$$

Indoor Worker Air Noncancer Equation

$$SL_{\text{ind-air-inhrfc}} \left(\frac{\text{f}}{\text{m}^3} \right) = \frac{\text{THQ} \times \text{AT}_{\text{ind-a}} \left(\frac{365 \text{ days}}{\text{yr}} \times \text{ED}_{\text{ind}} (25 \text{ yr}) \right)}{\left(\frac{1}{\text{RfC} \left(\frac{\text{f}}{\text{m}^3} \right)} \right) \times \text{EF}_{\text{ind}} \left(\frac{250 \text{ days}}{\text{yr}} \right) \times \text{ED}_{\text{ind}} (25 \text{ yr}) \times \text{ET}_{\text{ind}} \left(\frac{8 \text{ hrs}}{\text{day}} \right) \times \left(\frac{1 \text{ day}}{24 \text{ hrs}} \right)}$$

Outdoor Worker Air Noncancer Equation

$$SL_{\text{out-air-inhr}} \left(\frac{f}{m^3} \right) = \frac{THQ \times AT_{\text{out-a}} \left(\frac{365 \text{ days}}{\text{yr}} \times ED_{\text{out}} (25 \text{ yr}) \right)}{\left(\frac{1}{RfC \left(\frac{f}{m^3} \right)} \right) \times EF_{\text{out}} \left(\frac{225 \text{ days}}{\text{yr}} \right) \times ED_{\text{out}} (25 \text{ yr}) \times ET_{\text{out}} \left(\frac{8 \text{ hrs}}{\text{day}} \right) \times \left(\frac{1 \text{ day}}{24 \text{ hrs}} \right)}$$

Refractory Ceramic Fibers Air RSLs (fibers/m³)

Land Use	THI = 0.1	THI = 1.0
Resident	3128	31286
Composite Worker	13140	131400
Indoor Worker	13140	131400
Outdoor Worker	14600	146000

5.24 Lanthanum Salts

The oral chronic RfDs for lanthanum salts, used in this website, are derived from the PPRTV <<https://iris.epa.gov/document/&deid=342811>> oral chronic RfD for lanthanum by molecular weight (MW) adjustments and stoichiometric calculations. Lanthanum chloride, anhydrous (LaCl₃) has a MW of 245.27, and lanthanum (La) has a MW of 138.91. To derive the chronic oral RfD of 2.83E-05 mg/kg-day for lanthanum chloride, anhydrous, the lanthanum RfD of 5E-05 mg/kg-day is multiplied by the MW of lanthanum (138.91) divided by the MW of lanthanum chloride, anhydrous (245.27). To derive the chronic oral RfD of 1.87E-05 mg/kg-day for lanthanum chloride heptahydrate, the lanthanum RfD of 5E-05 mg/kg-day is multiplied by the MW of lanthanum (138.91) divided by the MW of lanthanum chloride heptahydrate (371.37). To derive the chronic oral RfD of 1.60E-05 mg/kg-day for lanthanum nitrate hexahydrate, the lanthanum RfD of 5E-05 mg/kg-day is multiplied by the MW of lanthanum (138.91) divided by the MW of lanthanum nitrate hexahydrate (433.01). To derive the chronic oral RfD of 2.08E-05 mg/kg-day for lanthanum acetate hydrate, the lanthanum RfD of 5E-05 mg/kg-day is multiplied by the MW of lanthanum (138.91) divided by the MW of lanthanum acetate hydrate (334.05).

5.25 MCLs for Trihalomethanes and Haloacetic Acids

The individual trihalomethanes (bromodichloromethane; bromoform; dibromochloromethane, chloroform) all have the MCL of 80 µg/L listed in the RSL table. However, 80 µg/L is the MCL for Total Trihalomethanes. The individual haloacetic acids (dichloroacetic acid, trichloroacetic acid, chloroacetic acid, bromoacetic acid, and dibromoacetic acid) all have the MCL of 60 µg/L listed in the RSL table. However, 60 µg/L is the MCL for Total haloacetic acids.

5.26 Perchlorate

The tapwater screening level for Perchlorate of 14 µg/L is different from the preliminary remedial goal (PRG) of 15 µg/L calculated by the Office of Solid Waste and Emergency Response in its January 8, 2009, guidance (PDF) . As described in the OSWER memorandum, the Agency issued an Interim Drinking Water Health Advisory (Interim Health Advisory) for exposure to perchlorate of 15 µg/L in water. A health advisory provides technical guidance to federal, state, and other public health officials on health effects, analytical methods and treatment technologies associated with drinking water contamination. The Interim Health Advisory for perchlorate was developed using EPA's RfD of 7E-04 mg/kg-day and representative body weight, as well as 90th percentile drinking water and national food exposure data for pregnant women in order to protect the most sensitive population identified by the National Research Council (NRC) (i.e., the fetuses of pregnant women who might have hypothyroidism or iodide deficiency).

The NCP (40 CFR 300.430(e)(2)(A)(1)) provides that when establishing acceptable exposure levels for use as remediation goals (for a Superfund site), consideration must be given to concentration levels to which the human population, including sensitive subgroups, may be exposed without adverse effects over a lifetime or part of a lifetime, incorporating an adequate margin of safety. As a result of the publication of the Interim Health Advisory for perchlorate, OSWER recommends that where no federal or state applicable or relevant and appropriate (ARAR) requirements exist under federal or state laws, 15 µg/L (or 15 ppb) is recommended as the PRG for perchlorate when making CERCLA site-specific cleanup decisions where there is an actual or potential drinking water exposure pathway. However, where State regulations qualify as ARARs for perchlorate, the remediation goals established shall be developed considering the State regulations that qualify as ARARs, as well as other factors cited in the NCP (see 40 CFR 300.430(e)(2)(i)(ff)). Final remediation goals and remedy decisions are made in accordance with 40 CFR 300.430 (e) and (f) and associated provisions.

Preliminary remediation goals are the starting points in the development of final cleanup levels at sites. As at all sites addressed under the NCP, these goals may be modified, depending on physical characteristics of a site, State laws and guidance, and other site specific factors, such as additional exposure routes.

The tapwater screening level of 14 µg/L is based on EPA's RfD and using standard RSL equations.

5.27 Styrene-acrylonitrile trimer (SAN Trimer)

Styrene-acrylonitrile trimer (SAN Trimer) is a by-product of specific manufacturing processes for polymers of styrene and acrylonitrile and a mixture of isomers formed by the condensation of two moles of acrylonitrile and one mole of styrene and has a molecular weight of 210. The mixture is composed of two structural forms: 4-cyano-1,2,3,4-tetrahydro-a-methyl-1-naphthaleneacetonitrile (THNA, CASRN 57964-39-3) and 4-cyano-1,2,3,4-tetrahydro-1-naphthalenepropionitrile (THNP, CASRN 57964-40-6). The THNA form consists of four stereoisomers: cis-R-THNA (CASRN 142759-38-4), cis-S-THNA (CASRN 142759-39-5), trans-R-THNA (CASRN 142759-37-3), and trans-S-THNA (CASRN 142759-40-8). The THNP form consists of two stereoisomers: cis-THNP (CASRN 142681-91-2) and trans-THNP (CASRN 142681-92-3). The NTP report [\[7\]](#) provides details regarding the structure and toxicity study for the mixture.

The SAN Trimer mixture is analyzed in environmental media using gas chromatography that yields three peaks. The total concentration corresponds to the total area of the three peaks. The Regional Screening Levels provide RSLs based on the oral Reference Dose for the SAN Trimer derived from the toxicity study described above. The PPRTV

[RfD used to derive the RSLs is based on the SAN Trimer mixture. The SAN Trimer structural isomers are listed separately in the RSL calculator but are the same values for the individual isomers. To evaluate the non-cancer toxicity of the SAN Trimer, compare the total concentration calculated based on the total of the three peaks to the RSL for either isomer.](https://iris.epa.gov/document/&deid=340093)

5.28 *cis-* and *trans*-Chlordane Surrogate

According to an April 7, 2021 memo [\[8\]](https://semsub.epa.gov/src/document/hq/100002784) from the Office of Research and Development,

“..technical chlordane can be considered a suitable surrogate for oral, noncancer screening-level assessments of *cis-* and *trans*-chlordane”.

Beginning in May 2021, the RSLs will use the technical chlordane (12789-03-6) Reference Dose as a surrogate for *cis*-chlordane (5103-71-9, alpha-chlordane) and *trans*-chlordane (5103-74-2, gamma-chlordane).

6. Recommended Default Exposure Parameters

Table 1 presents the definitions of the most commonly used variables and their default values. All the variables and their default values are available in this spreadsheet file

<https://semspub.epa.gov/src/document/hq/403621> or this PDF

<https://semspub.epa.gov/src/document/hq/403620>. The calculator follows the recommendations in the OSWER Directive https://epa-prgs.ornl.gov:8085/radionuclides/efh_changes_table_memo_2014.pdf concerning use of exposure parameters from the 2011 Exposure Factors Handbook

<https://iris.epa.gov/document/&deid=236252>. Any alternative values or assumptions used in remedy evaluation or selection on a CERCLA site should be presented with supporting rationale in Administrative Records.

• **Table 1. Recommended Default Exposure Parameters and Variable Definitions**

Symbol	Definition (units)	Default	Reference
SL	Screening Level (mg/kg, µg/L, or µg/m ³)	Contaminant-specific	Determined in this calculator
TR	Target Risk	1×10^{-6}	Selected by user
THQ	Target Hazard Quotient	0.1	Selected by user
AT	Averaging Time (days)	365 x LT (carcinogenic) 365 x ED (non-carcinogenic)	U.S. EPA 1989 (pg. 6-23)
LT	Lifetime (years)	70	U.S. EPA 1989 (pg. 6-22)
IRW	Ingestion Rate - Water (L/day)	0.78 (child) 2.5 (adult)	OSWER Directive
IRS	Ingestion Rate - Soil (mg/day)	200 (child) 100 (adult)	U.S. EPA 1991a (pg. 15)
IRF	Ingestion Rate - Fish (mg/day)	site-specific	Recommend using site-specific values
SA _{res-c}	Surface Area soil - (cm ² /day)	2373 (child - soil) 6032 (adult - soil) 3527 (worker - soil) 6365 (child - water) 19652 (adult - water)	OSWER Directive

AF	Soil Adherence Factor (mg/cm ²)	0.2 (child) 0.07 (adult) 0.12 (worker) 0.3 (construction worker)	U.S. EPA 2004 (Exhibit 3-5), RAGS Part E
BW	Body Weight (kg)	15 (child) 80 (adult)	U.S. EPA 1991a (pg. 15)
ABS _d	Fraction of contaminant absorbed dermally from soil (unitless)	contaminant- specific Inorganic default = none VOC default = none SVOC default = 0.1	U.S. EPA 2004 (Exhibit 3-4 and section 3.2.2.4)
GIABS	Fraction of contaminant absorbed in gastrointestinal tract (unitless) Note: if the GIABS is >50% then it is set to 100% for the calculation of dermal toxicity values.	contaminant- specific inorganic default = 1.0 VOC default = 1.0 SVOC default = 1.0	U.S. EPA 2004 (Exhibit 4-1 and section 4.2)
EF	Exposure Frequency (days/year)	350 (resident) 250 (indoor worker) 225 (outdoor worker)	U.S. EPA 1991a (pg. 15)
ED	Exposure Duration (years)	26 (resident) 6 (child) 20 (adult) 25 (worker) 1 (construction worker)	OSWER Directive

ET	Exposure Time - Air (hours/day)	24 (resident) 8 (worker)	The whole day The work day
ET _{event}	Exposure Time - Water (hours/event)	0.54 (child) 0.71 (adult)	U.S. EPA 2011, Table 16-28; weighted average of 90th percentile time spent bathing (birth to <6 years)
EV	Events (events/day)	site-specific	Site-specific
DAF	Dilution Attenuation Factor (unitless)	1 (or site-specific)	U.S. EPA. 2002 Equation 4-11
PEF	Particulate Emission Factor (m ³ /kg)	1.36 x 10 ⁹	U.S. EPA 2002 Exhibit D-2
VF	Volatilization Factor (m ³ /kg)	contaminant-specific	U.S. EPA. 2002 Equation 4-8

7. References

U.S. EPA (Environmental Protection Agency). 1987. Processes, Coefficients, and Models for Simulation Toxic Organics and Heavy Metals in Surface Waters. EPA/600/3-87/015. Office of Research and Development, Athens, GA.

U.S. EPA 1989. Risk assessment guidance for Superfund. Volume I: Human health evaluation manual (Part A)(PDF) <<https://semspub.epa.gov/src/document/hq/191>> (289 pp, 6.9 MB). Interim Final. Office of Emergency and Remedial Response. EPA/540/1-89/002.

U.S. EPA 1991a. Human health evaluation manual, supplemental guidance: "Standard default exposure factors (PDF) <<https://semspub.epa.gov/src/document/hq/190591>> (28 pp, 248 K)". OSWER Directive 9285.6-03.

U.S. EPA 1991b. Risk Assessment Guidance for Superfund, Volume I: Human Health Evaluation Manual (Part B, Development of Risk-Based Preliminary Remediation Goals) (PDF) <<https://semspub.epa.gov/src/document/hq/192>> (68 pp, 721 K). Office of Emergency and Remedial Response. EPA/540/R-92/003. December 1991

U.S. EPA. 1996a. Soil Screening Guidance: User's Guide. Office of Emergency and Remedial Response. Washington, DC. OSWER No. 9355.4-23 <<https://epa.gov/superfund/superfund-soil-screening-guidance>>

U.S. EPA. 1996b. Soil Screening Guidance: Technical Background Document. Office of Emergency and Remedial Response. Washington, DC. OSWER No. 9355.4-17A <<https://epa.gov/superfund/superfund-soil-screening-guidance>>

U.S. EPA. 1997a. Exposure Factors Handbook (PDF) <<https://iris.epa.gov/document/&deid=12464>> (854 pp, 7.7 MB). Office of Research and Development, Washington, DC. EPA/600/P-95/002Fa.

U.S. EPA 2000. Exposure and Human Health Reassessment of 2,3,7,8-Tetrachlorodibenzo-p-Dioxin (TCDD) and Related Compounds. Part I: Estimating Exposure to Dioxin-Like Compounds. Volume 3--Properties, Environmental Levels, and Background Exposures. Draft Final Report. EPA/600/P-00/001. Office of Research and Development, Washington, DC. September.

U.S. EPA, 2000b. Methodology for Deriving Ambient Water Quality Criteria for the Protection of Human Health (PDF) <<https://epa.gov/sites/default/files/2018-10/documents/methodology-wqc-protection-hh-2000.pdf>>(185 pp, 790 K).

U.S. EPA, 2001 (PDF) <<https://semspub.epa.gov/src/document/03/2218724>>(38 pp, 185 K). WATER9. Version 1.0.0. Office of Air Quality Planning and Standards, Research Triangle Park, NC. Web site <<http://www3.epa.gov/ttn/chief/software/water/index.html>>.

U.S. EPA 2002. Supplemental Guidance for Developing Soil Screening Levels for Superfund Sites. OSWER 9355.4-24. December 2002 <<https://epa.gov/superfund/superfund-soil-screening-guidance>>.

U.S. EPA 2004. Risk Assessment Guidance for Superfund Volume I: Human Health Evaluation Manual (Part E, Supplemental Guidance for Dermal Risk Assessment) Final. OSWER 9285.7-02EP. July 2004. Document (PDF) <<https://semspub.epa.gov/src/document/hq/195>> (186 pp, 4.2 MB) and website <<https://epa.gov/risk/risk-assessment-guidance-superfund-rags-part-e>>.

U.S. EPA 2005. Supplemental Guidance for Assessing Susceptibility from Early-Life Exposure to Carcinogens. March 2005. Document (PDF) <<https://semspub.epa.gov/src/document/hq/190690>> (166 pp, 468 K)

U.S. EPA 2009. Risk Assessment Guidance for Superfund Volume I: Human Health Evaluation Manual (Part F, Supplemental Guidance for Inhalation Risk Assessment) Final. OSWER 9285.7-82. January 2009. Document (PDF) <<https://semspub.epa.gov/src/document/hq/140530>> (68 pp, 724 K), memo (PDF) <<https://semspub.epa.gov/src/document/hq/140529>> (3 pp, 487 K) and website <<https://epa.gov/risk/risk-assessment-guidance-superfund-rags-part-f>>.

U.S. EPA 2011. Exposure Factors Handbook 2011 Edition (Final). National Center for Environmental Assessment, Office of Research and Development. Washington D.C. Currently available online at the EFH webpage or download here (PDF) <<https://semspub.epa.gov/src/document/hq/190592>> (1436 pp, 21.3 MB).

U.S. EPA 2012. OSWER Directive 9200.1-113: Compilation and Review of Data on Relative Bioavailability of Arsenic in Soil <<https://semspub.epa.gov/src/document/hq/175339.pdf>>. Washington, DC.

U.S. EPA 2014. OSWER Directive 9200.1-120 (PDF) <<https://semspub.epa.gov/src/document/hq/190670>> (7 pp, 1.1 MB). Washington, DC.

U.S. EPA 2019. Exposure Factors Handbook Chapter 3 Updates <<https://epa.gov/expobox/exposure-factors-handbook-chapter-3>> Office of Research and Development,, Washington, DC.

For assistance/questions please use the Regional Screening Levels (RSLs) contact us <<https://epa.gov/risk/forms/contact-us-about-regional-screening-levels-rsls>> page. For general risk assessment questions, separate from the RSLs, please use the link below.

[Risk Assessment Home <https://epa.gov/risk>](https://epa.gov/risk)

[About Risk Assessment <https://epa.gov/risk/about-risk-assessment>](https://epa.gov/risk/about-risk-assessment)

[Risk Recent Additions <https://epa.gov/risk/recent-additions-risk-assessment>](https://epa.gov/risk/recent-additions-risk-assessment)

[Human Health Risk Assessment <https://epa.gov/risk/human-health-risk-assessment>](https://epa.gov/risk/human-health-risk-assessment)

[Ecological Risk Assessment <https://epa.gov/risk/ecological-risk-assessment>](https://epa.gov/risk/ecological-risk-assessment)

[Risk Advanced Search <https://assessments.epa.gov/risk/advanced_search/>](https://assessments.epa.gov/risk/advanced_search/)

[Risk Assessment Guidance <https://epa.gov/risk/risk-assessment-guidance>](https://epa.gov/risk/risk-assessment-guidance)

[Risk Tools and Databases <https://epa.gov/risk/human-health-risk-models-and-tools>](https://epa.gov/risk/human-health-risk-models-and-tools)

[Superfund Risk Assessment <https://epa.gov/risk/superfund-risk-assessment>](https://epa.gov/risk/superfund-risk-assessment)

[Where you live <https://epa.gov/risk/where-you-live-risk-assessment>](https://epa.gov/risk/where-you-live-risk-assessment)

Contact Us <<https://epa.gov/risk/forms/contact-us-about-risk-assessment>> to ask a question, provide feedback, or report a problem.

LAST UPDATED ON FEBRUARY 29, 2024



Discover.

Accessibility Statement

<<https://epa.gov/accessibility/epa-accessibility-statement>>

Budget & Performance

<<https://epa.gov/planandbudget>>

Contracting

<<https://epa.gov/contracts>>

EPA www Web Snapshot

<<https://epa.gov/utilities/wwwwepagov-snapshots>>

Grants

<<https://epa.gov/grants>>

No FEAR Act Data

<<https://epa.gov/ocr/whistleblower-protections-epa-and-how-they-relate-non-disclosure-agreements-signed-epa>>

Plain Writing

<<https://epa.gov/web-policies-and-procedures/plain-writing>>

Privacy

<<https://epa.gov/privacy>>

Privacy and Security Notice

<<https://epa.gov/privacy/privacy-and-security-notice>>

Connect.

Data

<<https://epa.gov/data>>

Inspector General

<<https://www.epaig.gov/>>

Jobs

<<https://epa.gov/careers>>

Newsroom

<<https://epa.gov/newsroom>>

Regulations.gov



<<https://www.regulations.gov/>>

Subscribe

<<https://epa.gov/newsroom/email-subscriptions-epa-news-releases>>

USA.gov



<<https://www.usa.gov/>>

White House



<<https://www.whitehouse.gov/>>

Ask.

Contact EPA

<<https://epa.gov/home/form-s/contact-epa>>

EPA Disclaimers

<<https://epa.gov/web-policies-and-procedures/epa-disclaimers>>

Hotlines

<<https://epa.gov/aboutepa/epa-hotlines>>

FOIA Requests

<<https://epa.gov/foia>>

Frequent Questions

<<https://epa.gov/home/frequent-questions-specific-epa-programtopics>>

Follow.



APPENDIX 3

VAPOR INTRUSION ACTION LEVELS

- Vapor Intrusion Attenuation Factors (Brewer et al 2014)
- Relevant portions of User's Guidance for the Johnson and Ettinger (1991) Model for Subsurface Vapor Intrusion into Buildings
- Sensitivity Analysis of the Johnson and Ettinger (1991)

Estimation of Generic Subslab Attenuation Factors for Vapor Intrusion Investigations

by Roger Brewer, Josh Nagashima, Mark Rigby, Martin Schmidt, and Harry O'Neill

Abstract

Generic indoor air:subslab soil gas attenuation factors (SSAFs) are important for rapid screening of potential vapor intrusion risks in buildings that overlie soil and groundwater contaminated with volatile chemicals. Insufficiently conservative SSAFs can allow high-risk sites to be prematurely excluded from further investigation. Excessively conservative SSAFs can lead to costly, time-consuming, and often inconclusive actions at an inordinate number of low-risk sites. This paper reviews two of the most commonly used approaches to develop SSAFs: (1) comparison of paired, indoor air and subslab soil gas data in empirical databases and (2) comparison of estimated subslab vapor entry rates and indoor air exchange rates (IAERs). Potential error associated with databases includes interference from indoor and outdoor sources, reliance on data from basements, and seasonal variability. Heterogeneity in subsurface vapor plumes combined with uncertainty regarding vapor entry points calls into question the representativeness of limited subslab data and diminishes the technical defensibility of SSAFs extracted from databases. The use of reasonably conservative vapor entry rates and IAERs offers a more technically defensible approach for the development of generic SSAF values for screening. Consideration of seasonal variability in building leakage rates, air exchange rates, and interpolated vapor entry rates allows for the development of generic SSAFs at both local and regional scales. Limitations include applicability of the default IAERs and vapor entry rates to site-specific vapor intrusion investigations and uncertainty regarding applicability of generic SSAFs to assess potential short-term (e.g., intraday) variability of impacts to indoor air.

Introduction

Risk-based screening levels for soil, groundwater, and soil gas are often included in vapor intrusion guidance documents. Such screening levels, particularly for groundwater and soil gas, are important tools for rapid identification of potential vapor intrusion risks (VIRs) as well as for expediting the clearance of low-risk sites from additional agency oversight. A key parameter in calculating these screening levels is the indoor air:subslab soil gas attenuation factor (SSAF). This factor reflects the degree of mixing and dilution of intruding soil gas with indoor air (Figure 1) and can be calculated empirically as follows:

$$\text{SSAF} = \frac{\text{Concentration in indoor air}}{\text{Concentration in subslab soil gas}} \quad (1)$$

Subslab soil gas screening levels are generated by selecting a default attenuation factor and indoor air concentration into this equation and solving for the subslab concentration:

Subslab soil gas screening level

$$= \frac{\text{Indoor air screening level}}{\text{SSAF}} \quad (2)$$

Fate and transport models can be used to develop equivalent screening levels for soil and groundwater, based on the target concentration of the volatile organic compound (VOC) in subslab soil gas and the equilibrium partitioning characteristics of the targeted chemical (e.g., U.S. Environmental Protection Agency [USEPA] 2004).

This paper evaluates two of the most commonly used approaches for developing default SSAFs for use in vapor intrusion guidance: (1) direct measurement of apparent attenuation based on empirical databases of paired indoor air and subslab soil gas data and (2) estimation of attenuation factors based on vapor entry rates and indoor air exchange rates (IAERs). In the first case, the SSAF is estimated by dividing the measured chemical concentration in indoor air by its subslab soil gas concentration. In the second case, the SSAF is estimated by dividing the vapor entry rate by the IAER in terms of volume per unit of time. The vapor entry rate is referred to as " Q_{soil} " in United States Environmental Protection Agency (USEPA) guidance (USEPA 2004), although a more accurate term would be " Q_{floor} " since vapor flow through the floor (rather than out of the soil) is the primary parameter of interest. This modification recognizes that the model can also be used for buildings with crawl spaces. The IAER for a building represents the number of times that the total volume of air in the building is replaced with fresh air each hour and

© 2014 The Authors. Groundwater Monitoring & Remediation published by Wiley Periodicals, Inc. on behalf of National Ground Water Association. doi: 10.1111/gwmmr.12086

This is an open access article under the terms of the Creative Commons Attribution License, which permits use, distribution and reproduction in any medium, provided the original work is properly cited.

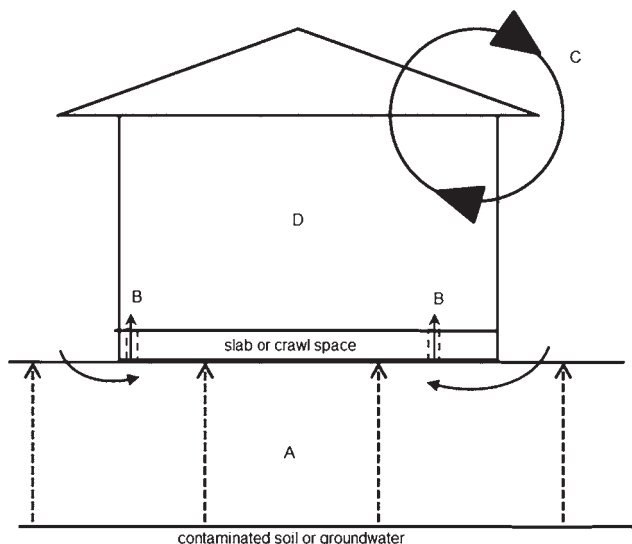

Figure 1. Simplified conceptual site model of vapor intrusion and attenuation in indoor air: (A) upward diffusion of vapors from the source area through vadose zone soil; (B) advective flow of subslab vapors into depressurized building via cracks, utility gaps, etc., in the floor; (C) exchange of indoor air and outdoor air due to climate-induced leakage and/or mechanical ventilation; (D) attenuation of subslab vapors upon mixing with indoor air.

is traditionally presented in terms of the number of building air exchanges per unit time (e.g., exchanges per hour; USEPA 2004, 2011). An IAER of 1/h, for example, indicates that indoor air is replaced once every hour. A default indoor air volume of 244 m³ for a one-story, single-family residence is recommended in USEPA vapor intrusion guidance (100 m² floor area and 2.44 m height; USEPA 2004).

Selection of one approach over the other for developing generic SSAFs profoundly affects the assumed VIR. Inadequately conservative attenuation factors can allow high-risk sites to be prematurely excluded from further investigation. Excessively conservative attenuation factors can lead to costly and often inconclusive investigations.

A large database of groundwater, soil gas, and indoor air data has been compiled by the USEPA (2012b) and is the primary source of data being used to develop empirically based attenuation factors. This paper focuses on the paired, subslab, and indoor air data in the database used to derive SSAFs. Concerns highlighted for the technical basis of proposed subslab attenuation factors also likely apply to deeper soil gas and groundwater data (e.g., Yao et al. 2013a). However, the authors consider the subslab data to be most prone to potential errors in decision making, and an important starting point for a more detailed review of the adequacy of the database for the development of technically defensible, attenuation factors in general.

Use of Empirical Databases to Calculate Attenuation Factors

Calculation of SSAFs

Calculation of an SSAF based on indoor air and subslab data collected at a building would ideally be very

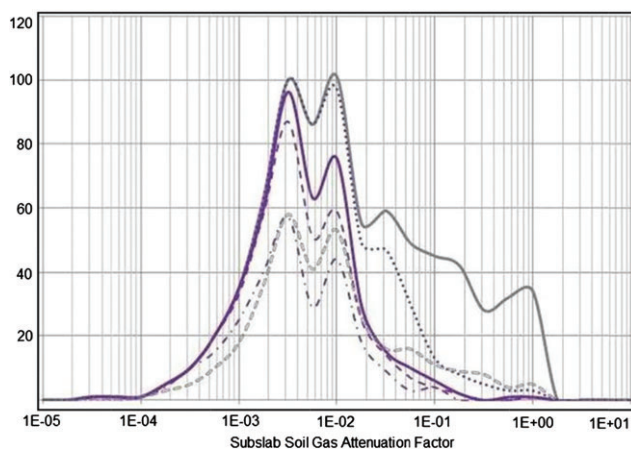

Figure 2. Range and frequency of ratios of indoor air to subslab soil gas data for individual buildings included in the USEPA database, assumed to represent SSAFs for the structures (from USEPA 2012b).

straightforward; that is, the concentration of a volatile measured in indoor air is divided by its subslab concentration (see Equation 1). This approach is used to estimate a subslab vapor attenuation factor for more than 1000 buildings included in the USEPA database (USEPA 2012b). The range and frequency of estimated attenuation factors are presented in Figure 2. Different plots on the graph reflect different filters applied to the database, with the purple plot representing data sets where VOCs in subslab soil gas samples were 50 times greater than the anticipated indoor air background. Statistical analysis of this particular set of data is used to generate generic SSAFs for general screening purposes, resulting in a median value of 0.003 and a 95th percentile value of 0.03. (Note that the reported median value also appears to be approximately coincidental with the mode.)

While elegant in its apparent simplicity, this approach requires two important assumptions (see also USEPA 2012a): (1) indoor air data are representative of vapor impacts and (2) subslab soil gas represents intruding vapors associated with those impacts. If these criteria cannot be established within a reasonable degree of accuracy for each data pair, then the estimated SSAF becomes questionable, as does any statistical evaluation of the database as a whole.

Indoor Air Data

The risk posed to building occupants by intruding vapors is typically assessed in terms of long-term impacts to indoor air. The objective of indoor air sampling is to estimate the associated long-term average concentration of intrusion-related VOCs in areas of the building that a person regularly occupies. The degree to which the indoor air data included in the USEPA (2012b) vapor intrusion database meets this objective is hampered by a number of potential sources of error, including: (1) masking of low-level vapor intrusion impacts by VOCs from indoor and/or outdoor sources, (2) collection of samples from rooms not representative of normally occupied areas, and (3) reliance in most cases on a single sample to characterize this area (refer to Table 1 in the USEPA document).

Note that the reported concentrations of VOCs in indoor air were within the assumed background levels for most of

Table 1

Weighted Vapor Entry Rates for Designated Vapor Intrusion Risk Regions

VIR Region¹	Average Number of Cooling Days per Year^{2,3}	Average Number of Non-Cooling or Heating Days per Year^{3,4}	Weighted Annual-Average Vapor Entry Rate⁵ (L/min)
Region A (Cold) ⁶	62	303	4.5
Region B (Warm) ⁷	122	243	4.0
Region C (Mediterranean) ⁸	199	166	3.4
Region D (Tropical) ⁹	365	0	2.0

¹Vapor intrusion risk regions (see Figure 4).

²Number of days per year with mean temperature >65 °F in Regions A, B, and D and >55 °F in Region C.

³Based on mean daily temperatures published by NOAA (2013) for the contiguous 48 states and DRI (2013) for Hawai‘i and Alaska; 15-d period assigned to months when mean daily temperature between different areas of the region were both above and below the target CDD-HDD cutoff.

⁴Number of days per year with mean temperature <65 °F in Regions A, B, and D and <55 °F in Region C.

⁵Weighted vapor entry estimated based on assumed maximum effective entry rate of 2 L/min on cooling days and 5 L/min on non-cooling or heating days per 100 m² building slab area (see text).

⁶Cold climate region represented by northern and Rocky Mountain states with mean daily temperature >65 °F from at least July through August; includes Alaska (see text).

⁷Warm climate region represented by southern and southwestern states with mean daily temperature >65 °F from at least June through September.

⁸Mediterranean climate region represented by coastal central California with cool summers and mean daily temperature >55 °F from mid-April through October.

⁹Tropical climate region represented by Hawai‘i, southernmost Florida, Puerto Rico, the United States Virgin Islands, and Guam, with year-round mean daily temperature >65 °F.

the samples in the database. Of the samples that exceeded the anticipated background levels, the majority were still within an order of magnitude of these values. This is compensated for in the USEPA (2012b) database report in part by filtering the data with respect to the assumed range of background VOCs in indoor air. Of the original 1231 sets of paired subslab and indoor air data sets, 464 were filtered out in order to address known or suspected indoor sources, concentrations of VOCs in the subslab soil gas sample that are less than that reported for indoor air, and other potentially complicating factors. All but 320 sets of paired data were eliminated after screening out indoor air data that fell within the assumed background range of a VOC.

This compromises the representativeness of SSAFs extracted from the database since sites with very low SSAFs and sites where vapor intrusion was not occurring were excluded from further consideration. Contributions from indoor or ambient sources can cause subslab attenuation to be underestimated and can misrepresent cases where vapor intrusion is not occurring. The median, mean, and 95th percentile attenuation factors presented in the USEPA (2012b) report are, therefore, biased toward cases with less attenuation (higher attenuation factors) and do not reflect the database population as a whole.

The USEPA (2012b) database assessment includes an alternate filter that focuses on subslab soil gas data greater than various multiples of the anticipated background (e.g., 100; see Figure 2). However, this again does not address uncertainty in the representativeness of the “high source strength” soil gas data in terms of vapors that actually intruded into the structure and impacted indoor air. Variability of vapor concentrations in the subslab could lead to the presence of both “low source strength” and “high source strength” areas under the same slab. Whether impacts to indoor air were tied to a high vs. low source strength would depend on the location of the vapor entry point rather than where the subslab sample was collected. The reliability of an SSAF derived for an apparent “high source strength” data pair would be no more reliable than an SSAF derived for an apparent “low source strength” data pair.

More than 75% of the indoor air samples included in the database were collected from residential basements. Basements are an important potential source of indoor air contaminants due to the upward flow of air when the lower living area of the house is depressurized with respect to outdoor air, for example when the house is heated (Dodson et al. 2007; USEPA 2007a). The ventilation of basements relative to upper levels is not recorded in the USEPA database, and the representativeness of the samples from upper levels cannot be quantitatively assessed. As discussed subsequently, minimum ventilation standards for regularly occupied areas are required under the building permit (American Society of Heating, Refrigerating and Air-Conditioning Engineers [ASHRAE] 2013a, 2013b). A higher air exchange rate in upper areas of the building would further attenuate vapors due to leakage and ventilation, making indoor air data from these areas more representative of risk to occupants.

Reliance on a single indoor air sample for most of the pairs in the database poses an additional source of potential error. Studies where large numbers of concurrent indoor air samples are collected indicate that VOC concentrations can vary spatially within the same building by up to four orders of magnitude for large commercial buildings and by a factor of three for smaller residential buildings (Otson and Fellin 1992; Eklund et al. 2008; Folkes et al. 2009; USEPA 2011, 2012b). Concentrations of volatiles in indoor air at vapor intrusion sites have also been demonstrated to vary by as much as three orders of magnitude over time (Folkes et al. 2009; Song et al. 2011; Holton et al. 2013).

Spatial variability can be addressed in part by the collection of a sample over a longer period that accounts for natural circulation and mixing of indoor air. To meet this objective, 24-h samples are often considered adequate (e.g., California Environmental Protection Agency [CalEPA] 2011). Longer duration samples also take into account diurnal effects of vapor intrusion. However, the duration of sample collection for each subject building is not discussed in the USEPA database report, introducing another potential source of error into the data used to derive the SSAFs.

The USEPA document acknowledges these sources of potential error for indoor air samples in the database (USEPA 2012b; see also USEPA 2012a). The representativeness of indoor air data is difficult to quantify, and confidence in estimated SSAFs is difficult to ascertain. However, potential error associated with the representativeness of subslab soil gas data in the database likely far outweighs the error associated with the indoor air data.

Subslab Soil Gas Data

Assessing the representativeness of subslab data in the USEPA database is more challenging than for indoor air. Potential sources of error include: (1) uncertainty in the relation between vapors currently under the slab with vapors previously intruded to indoor air; (2) uncertainty in the duration, entry rate, and volume of vapors intruded to indoor air; (3) potential discrepancies between vapor entry points and sample locations; and (4) reliance in most cases on a single subslab sample to characterize all of the vapors beneath a building.

Evaluating the representativeness of soil gas data first requires that the target population be identified, but this is less straightforward than for indoor air. Direct testing of the vapor that impacted the indoor air is, of course, not possible since the two have already mixed. Instead, vapors under the structure are assumed to represent vapors that intruded earlier, which introduces error in the SSAF calculations (USEPA 2012b; see also USEPA 2007b).

Uncertainty in the population of subslab soil vapors to be targeted for characterization introduces additional error into the database. Indoor vapors could be assumed to reflect the volume of vapor that intruded during the previous exchange of indoor air. For example, an IAER of 0.5/h (CalEPA 2011) and a vapor entry rate of 5 L/min (USEPA 2004) equate to a vapor entry rate of 600 L per air exchange (i.e., 2 h) for each 100 m² of building footprint (USEPA 2012a). Alternately, an assumed time period of 24 h would take into account diurnal effects (CalEPA 2011). Assuming a vapor entry rate of 5 L/min, this equates to a vapor plume volume of 7200 L.

Another option might be to assume that the volume of vapors immediately beneath the entire slab area represents the population of interest. The volume of air-filled pore spaces in the first 15 cm of soil beneath a 100 m² slab is approximately 4200 L, assuming an air-filled porosity of 28% (default parameter values are included in the USEPA vapor intrusion model; see USEPA 2004, 2012a). Some guidance documents suggest a source area of vapors beneath slabs as thick as 3 feet (e.g., CalEPA 2011), corresponding to a volume of soil gas of approximately 25,000 L.

A third source of potential error in subslab soil gas data in the USEPA database is the relationship between vapor entry points and sample locations. The specific location of subslab vapor samples in terms of potential vapor entry routes is not recorded in the USEPA database and in most cases is presumably unknown.

The total error associated with these factors alone is difficult or impossible to quantify. Acceptance of the SSAF with any reasonable degree of precision and accuracy requires a leap of faith that the sole subslab sample represents the hundreds or thousands of liters of vapors that

previously entered the building. These sources of error can be overlooked only if the concentrations of subslab vapors are relatively homogeneous.

This is highly unlikely. Most guidance documents recognize variability of VOC concentrations in subsurface vapor plumes, including the USEPA database document (American Petroleum Institute [API] 2005; New Jersey Department of Environmental Protection [NJDEP] 2013; Interstate Technology & Regulatory Council [ITRC] 2007; USDOD 2009; CalEPA 2012; USEPA 2012a, 2012b). Data for buildings where large numbers of subslab soil gas samples have been collected suggest that spatial variability of one to several orders of magnitude in VOC concentrations at the scale of a building slab (i.e., across the slab as a whole) is likely to be the rule rather than the exception (Widdowson et al. 1997; Choi and Smith 2005; McHugh et al. 2007; Luo et al. 2009; Johnson et al. 2012; Lutes et al. 2012; Schmidt 2012; O'Neill 2013; Yao et al. 2013a, 2013b, 2013c; Shen et al. 2013; see also McHugh et al. 2006; Tillman and Weaver 2006; USEPA 2012a). It is reasonable to assume that the reported concentration of a VOC in a small (e.g., 1 L) subslab soil gas sample represents the immediate area. However, closely spaced grids of passive soil gas samples in outdoor areas routinely identify order-of-magnitude variability over distances of a few feet (e.g., O'Neill 2013; Whetzel et al. 2009; see also American Society for Testing and Materials [ASTM] 2011). Similar variability has been identified in radon gas studies (e.g., Bunzl et al. 1998; Winkler et al. 2001). Variability in VOC concentrations in subslab soil gas is likely to be greatest when vapors are associated with small, isolated pockets of contaminated soil but can also be considerable for vapors attributed only to contaminated groundwater.

This inherent spatial variability of subslab vapors will have profound effects on the calculation of SSAFs based on empirical data. Figure 3 illustrates one example. The figure summarizes data for total petroleum hydrocarbons (TPH)

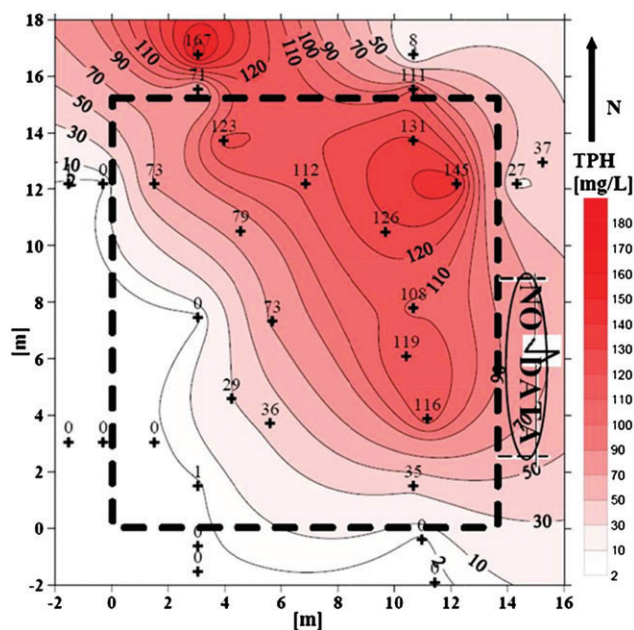

Figure 3. Isoconcentration map of TPH soil gas data beneath a building slab (from Luo et al. 2009).

in vapors beneath a 210 m² building slab (after Luo et al. 2009). Note that the concentration of TPH measured in 17 1-L soil gas samples collected beneath the slab of the building ranged from 0 to 145 mg/L (145,000,000 µg/m³). The maximum detected concentration exceeds the published, risk-based screening levels for TPH in subsurface soil gas by up to three orders of magnitude (e.g., see Brewer et al. 2013) and suggests potentially significant vapor intrusion concerns. This could be possible if the lower level of the structure was depressurized with respect to the subsurface air space, and if upward attenuation was insufficient to reduce TPH concentrations below the levels of concern before the vapors were drawn through entry points in the slab.

As evident in Figure 3, any estimate of an SSAF for the building depends on the location of the subsurface sample and could vary by orders of magnitude. As succinctly concluded by Luo et al. (2009, 89): “Random sampling of a few locations might not reveal the true range of concentrations... Even if one had precise knowledge of the subsurface soil gas distribution, it is not clear how it would be used to assess pathway significance without knowledge of the vapor entry points to the building and soil gas entry rates through those points.” The concentration of the VOC reported for the sole soil gas sample collected beneath the building could well simply reflect random “noise” in the vapor plume rather than the “signal” directly tied to vapor intrusion, that is, rather than the mean concentration of the VOC in soil gas tied to the measured impacts to indoor air (see also Silver 2012). The potential for multiple vapor entry points from areas under the slab with differing VOC concentrations and different entry rates further compromises the database reliability for estimation of the SSAF.

Confidence in USEPA Database SSAFs

Of the potential sources of error in the USEPA vapor intrusion database, spatial variability of VOC concentrations in subsurface soil gas is likely the most significant, in particular at the scale of a single 1-L sample. The effect of spatial (and temporal) variability on the reliability of attenuation factors extracted from the database is recognized but perhaps not fully appreciated in the USEPA (2012b, 15) report:

These factors may impart bias when calculating concentration ratios, depending on the extent to which the samples accurately represent the spatial and temporal variability of the indoor air concentrations and the subsurface vapor concentrations affecting the building... The spatial and temporal variability in observed subsurface and indoor air concentrations within and among buildings mean that for every site, *and every structure* (emphasis added) in an area of similar subsurface contamination, a range of empirical attenuation factors would likely be calculated from a series of discrete indoor air and subsurface vapor concentrations measured at different points in space or at different times.

This potential shortcoming of the database is similarly anticipated in vapor intrusion guidance published by the California Department of Toxic Substances Control. This guidance includes a default SSAF of 0.05 derived from earlier versions of the USEPA database (CalEPA 2011, 16): “The default attenuation factors assume [that] ...the

subsurface is reasonably homogeneous (uniform).” It goes on to provide an alternative, “site-specific” approach for calculating SSAF values based on the use of default vapor entry rates and IAERs. This is discussed in the following section.

The USEPA (2012b, 16) report continues, “Considering this variability, a statistical approach to characterizing the empirical attenuation factors was adopted...” However, this statement is misleading. Statistical evaluation of the database only addresses the variability *between* individual homes and buildings, not variability and error *within* a single data point. Any data set, accurate or not, can yield a pattern amenable to statistical analysis. Statistical analysis of a database is valid only if the individual data points represent their intended purpose within a quantifiable range of error (Silver 2012). This is clearly not the case for the paired indoor air and subsurface soil gas samples in the USEPA (2012b) database.

This variability highlights the perils of applying statistical approaches designed to evaluate databases in which the error associated with individual data points can reasonably be assumed to be minimal (e.g., age, height, weight, etc.) vs. databases in which the reproducibility of individual data points is uncertain (see Silver 2012). The Central Limit Theorem in this case no longer applies, and statistical analysis of the database cannot compensate for the unknown error. Although seemingly straightforward, the frequency graph presented in the USEPA database report (see Figure 2) cannot reliably be assumed to reflect the distribution of SSAFs for the individual homes and buildings included in the database. Subsequently, there is no technically defensible basis for using the 95th percentile SSAF value of 0.03 extracted from the database (see also McHugh et al. 2007). As discussed in the following section, the reported median ratio of 0.003 is similar to SSAFs calculated as the ratio of vapor flow to indoor air exchange in this paper. Whether this is coincidental or accurately reflects attenuation is uncertain and is not examined in detail.

Use of Indoor Air Exchange Rates and Subsurface Vapor Entry Rates to Estimate SSAFs

Calculation of Subsurface Attenuation Factors

An SSAF for a building can also be calculated from the ratio of the rate of subsurface vapor intrusion (“vapor entry rate”) to the rate of fresh air entering the building over the same time period, as represented by the IAER:

$$\text{SSAF} = \frac{\text{Vapor flow rate} \left(\frac{L}{\text{min}} \right)}{\text{Indoor air exchange rate} \left(\frac{L}{\text{min}} \right)} \quad (3)$$

The vapor entry rate is traditionally expressed in terms of a default building floor area of 100 m² (USEPA 2012a). In this sense, the term might be more appropriately defined as a “flux” rate. The term “entry” is, however, retained for use in this paper with the understanding that the value presented applies to a specific area of floor space. This mass balance approach is indirectly incorporated into the vapor intrusion models published by USEPA (2002, 2004), with the SSAF

equal to the ratio of the average vapor entry rate into a building (Q_{soil}) and the Building Ventilation Rate ($Q_{building}$) when vapor flow into the building is dominated by advection (see also Song et al. 2011). This same approach is used to develop generic screening levels by several states (e.g., CalEPA 2008, 2011; Hawaii Department of Health [HDOH] 2011; see also ITRC 2005). Note that the USEPA vapor intrusion models calculate a single “Infinite Source Indoor Attenuation Coefficient (alpha)” that takes into account total attenuation from the source area to indoor air, rather than separate attenuation factors for the source and subslab vapors and then for the subslab vapors and indoor air.

Calculation of the SSAF requires that the IAER be converted to units of volume and time identical to that used for vapor entry, or liters per minute:

$$\text{IAER} \left(\frac{L}{\text{min}} \right) = \text{IAER} \left(\frac{\text{Exchanges}}{\text{h}} \right) \times \frac{1\text{h}}{60\text{min}} \times \text{Volume} \left(\frac{m^3}{\text{Exchanges}} \right) \times 1000 \left(\frac{L}{m^3} \right). \quad (4)$$

The term “Volume” represents the interior volume of the structure.

As discussed next, the flow of subsurface vapors into homes and buildings has been extensively studied and is reasonably well understood. IAERs are understood within a relatively narrow range of error (Supporting Information, Appendix S1). Models and field studies have demonstrated that a building’s ventilation rate and soil gas entry rate are positively correlated (Cavallo et al. 1992; Song et al. 2014; see also Hers et al. 2001). In combination, they offer a technically defensible and more robust approach for estimating region-specific SSAFs that can be used to develop tools for vapor intrusion screening. An example of this approach is presented in the next section.

IECC Climate Zones and Designation of Vapor Intrusion Risk Regions

A “Climate Zone” approach similar to that used by Murray and Burmaster (1995) combined with the Köppen-Geiger (Peel et al. 2007) and Trewartha (Trewartha and Horn 1980) climate-classification schemes is used in combination with International Energy Conservation Code (IECC) maps (International Code Council [ICC] 2012) to subdivide the country into four, distinct “VIR” regions (Figure 4): (1) Region A (cold), (2) Region B (warm), (3) Region C (Mediterranean), and (4) Region D (tropical). Region B includes the coastal marine areas of northern California, Oregon, and Washington. Other specific areas included in the regions are discussed as follows.

The IECC climate zones characterize different regions of the United States in terms of “heating degree days” (HDD) and “cooling degree days” (CDD). Climate zone boundaries follow county boundary lines (see also U.S. Department of Energy [USDOE] 2010). The climate zones closely approximate climate-classification boundaries designated by the Köppen-Geiger (Peel et al. 2007) and Trewartha schemes (Trewartha and Horn 1980). An HDD value for a given day represents the difference between the average daily temperature and a base temperature of 65°F when the daily average temperature is below 65 °F. For example, if the average temperature for a given day is 40 °F, then the HDD value for that day is 25. Individual daily HDD values are summed to generate an annual HDD value for the location. Higher annual HDD values indicate a greater need for heating in comparison to locations with lower values. A CDD is a measure of how hot a location is over a period of time, relative to a base temperature of 50 °F (65 °F used by some entities). The CDD is the difference between that day’s average temperature and a temperature of 50 °F, if the daily average temperature is

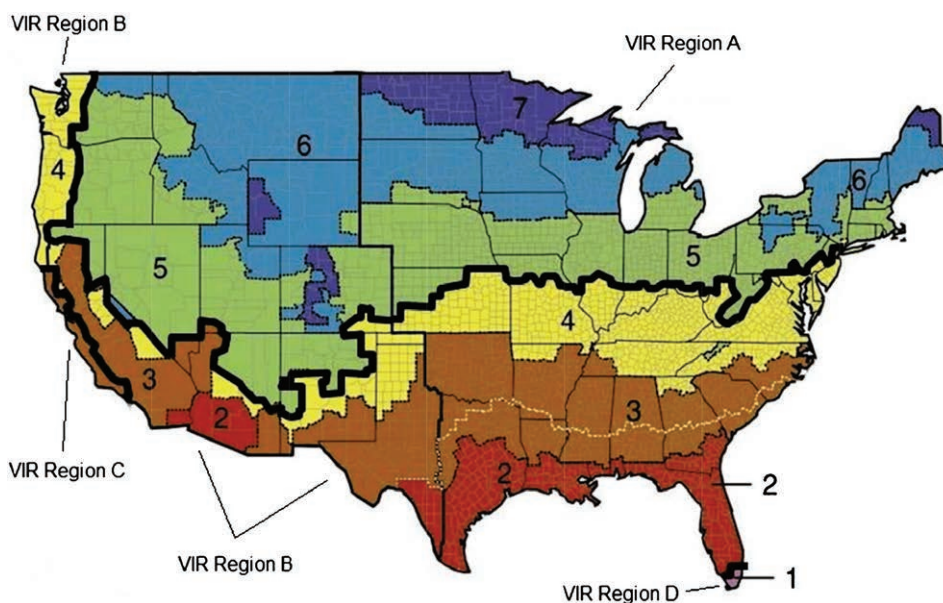

Figure 4. Example vapor intrusion risk (VIR) regions defined in terms of average building leakage rates and associated IAERs and vapor entry rates (see Tables 1 and 2; after ICC 2012). VIR Region A: Cold (includes Alaska); VIR Region B: Warm with Hot Summers (includes Marine/Oceanic coastal area of northern California, Oregon and Washington); VIR Region C: Mediterranean with Cool Summers (primarily coastal central California); VIR Region D: Tropical (not shown—Puerto Rico, the United States Virgin Islands, Hawai’i, and Guam).

greater than 50 °F (see ICC 2012). Daily CDD values are summed to generate an annual CDD value for the location. Higher annual CDD values indicate a greater need for cooling in comparison to locations with lower values.

The IECC climate zones are useful approximations of variation in regional IAERs. “Building leakage” models can be used to approximate a default, IAER, and vapor entry rate for each VIR region. The ratio of vapor entry rate to the IAER is then used to assign an SSAF to each VIR region.

Indoor Air Exchange Rates

Published Studies

Indoor air exchange takes place through a combination of three processes: (1) leakage of outdoor air into the structure around windows, doors, and rooflines and through cracks, gaps, and other openings; (2) natural ventilation via open windows, doors, and other openings; and (3) forced or mechanical ventilation driven by fans. IAER can be measured in the field using tracer tests (e.g., ASTM 1990; ASTM 2000; ASHRAE 2002, 2006, 2013a; Batterman et al. 2006; Bennett et al. 2012). Regional variations in IAER can be predicted by models that consider the types and sizes of houses, typical leakage properties, and representative weather conditions (e.g., Sherman and Matson 2011).

A review of published IAERs for different regions of the country is provided in Appendix S1. The example IAERs presented in the following section are based on a review of the noted references. Alternatively, less or more conservative IAERs could be applied on a more site-specific basis (e.g., refer to upper- and lower-bound distribution of air exchange rates summarized in USEPA 2011). However, coinciding vapor entry rates would require similar adjustment to correspond with the change in overall building leakage. Nonetheless, an assessment of the adequacy of building ventilation should be a fundamental part of all vapor intrusion investigations.

VIR Region A (“Cold”) Default IAER

A default IAER of 0.35/h is assigned to VIR Region A, including the northeastern, north central, and Rocky Mountain areas of the country as well as the inland area of Oregon and Washington and all of Alaska (IECC Climate Zones 5, 6, 7, and 8; ICC 2012). This area is characterized by the need to heat buildings for most of the year, with decreased periods when windows and doors are likely to be left open.

An IAER of 0.35/h corresponds to the minimum ventilation rate required for residential structures in the United States (ASHRAE 2013b; see also Lawrence Berkeley National Laboratory [LBNL] 1998; USDOE 2002; Manufactured Housing Research Alliance [MHRA] 2003; ASHRAE 2010; USEPA 2010). The IAER is similar to median, annual air exchange rates estimated by Murray and Burmaster (1995) for colder regions that have more than 5400 HDD per year (i.e., 0.32/h and 0.40/h for Climate Regions 1 and 2, respectively). Lower annual-average IAERs are possible but should be accompanied by proportionally lower vapor entry rates, offsetting the potential VIRs. Impacts to indoor air quality by indoor sources also become increasingly likely to mask and outweigh risks posed by vapor intrusion below

this exchange rate (see Hers et al. 2001; Gilbert et al. 2008; ASHRAE 2013a). Lower IAERs likewise indicate inadequate ventilation that should be identified and corrected as part of a vapor intrusion investigation.

VIR Region B (“Warm”) Default IAER

A default IAER of 0.50/h is assigned to VIR Region B, including the south, southwest, and the southernmost and Central Valley areas of California (IECC Climate Zones 2, 3, and 4 with the exception of coastal central California; ICC 2012; see Figure 4). This area is characterized by having less than 5,400 HDD per year. The default IAER again approximates the annual median air exchange rates estimated by Murray and Burmaster (1995) for their Climate Regions 3 and 4 (i.e., 0.44/h and 0.65/h, respectively). Yamamoto et al. (2010) similarly estimated that the median air exchange rate for homes in Texas was 0.47/h. Lower IAERs are primarily associated with tighter, newer homes in which air conditioning is used for most of the year (Sherman and Matson 2011). This should be accompanied by a lower to negligible vapor entry rate due to pressurization of the lower portions of the home (see also McHugh et al. 2012; Song et al. 2014).

California’s climate is highly diverse, with the southeastern corner of the state characterized by a hot desert-to-steppe climate, the coastal area stretching from the U.S.-Mexico border to just north of Los Angeles characterized by a Mediterranean climate with hot summers, and the southern half of the Central Valley characterized by a semi-arid steppe climate (Kaufmann 2003). These areas were included in VIR Region B due to the potential for heating during brief but cold winters. Studies specific to California estimate a range of IAERs from 0.5 to 1.5 times per hour (e.g., Wilson et al. 1996). The default IAER of 0.50/h assigned to VIR Region B corresponds to the default IAER recommended for the state as a whole in vapor intrusion guidance by the California Department of Toxic Substances Control (CalEPA 2011).

The Marine West Coast climate of coastal northern California (Humboldt, Trinity, and Del Norte counties) and coastal Oregon and Washington is also included in VIR Region B (Taylor and Hannan 1999; ICC 2012; see Figure 4). This area falls within IECC Climate Zone 4C (3600 < HDD < 5400; ICC 2012). These areas are classified as Mediterranean under the 1899 Köppen-Geiger scheme (Peel et al. 2007). The areas are more appropriately classified as Temperate Ocean Marine (Trewartha and Horn 1980) and are distinct from the true Mediterranean climate of coastal central California (see below) by having cooler temperatures and significantly higher rainfall. This can be expected to result in less ventilation from open windows and doors in comparison to VIR Region C, as well as an increased use of heating, resulting in lower average IAERs and, as discussed in the following, a higher annual-average subsurface vapor entry rate.

Residential IAERs in these areas as a whole are somewhat higher in comparison to IECC Climate Zones 5 to 8 due in part to increased periods of the year when open windows and doors are used for ventilation (refer to the aforementioned discussion and Murray and Burmaster 1995). Air exchange rates in the warmest regions, extending from

Florida to western Texas, are lower than might be expected due to tighter homes and the use of air conditioning for most of the year, compared to more moderate areas.

VIR Region C (Mediterranean) Default IAER

A default annual-average IAER of 1.0/h is assigned to VIR Region C. This includes the coastal central California and a thin sliver of land along the western edge of the Sierra Mountains, which is characterized by a Mediterranean climate with cool summers (Kauffman 2003; see Figure 4, Sierra area not depicted due to scale). The areas fall into IECC Climate Zone 3C (ICC 2012) and Climate Regions 3 and 4 of Murray and Burmaster (1995).

The area is distinct from Region B in terms of cooling and particularly heating. The selected IAER reflects year-round moderate temperatures and an increased use of windows and doors for ventilation, as well as minimal heating requirements during the winter. This is in agreement with the mid-range of IAERs identified for coastal areas (e.g., see Wilson et al. 1996; California Energy Commission [CEC] 2001; and Yamamoto et al. 2010) and is either consistent with or more conservative than peer-reviewed vapor intrusion guidance published by regulatory agencies located in these areas (e.g., Oakland Environmental Services Division 2000; CalEPA 2008). Natural ventilation is usually preferred to mechanical ventilation in these areas (Sherman 1995; ASHRAE 2013a). The IECC climate zone classification also reflects a reduced use of heating in coastal central California (Climate Zone 3C; HDD <3600) in comparison to interior California (Climate Zone 3B; HDD <5400). This helps to explain the comparatively higher IAERs for this area, even though the mean daily temperature dips slightly below the IECC HDD default of 65 °F for most of the year.

VIR Region D (Tropical) Default IAER

An annual-average IAER of 1.0/h is assigned to VIR Region D. This area includes southernmost Florida, Hawai'i, Puerto Rico, the United States Virgin Islands, and Guam (see Figure 4; latter areas not depicted) and falls into IECC Climate Zone 1 (ICC 2012). The default air exchange rate corresponds to the value incorporated into vapor intrusion guidance published by the State of Hawai'i (HDOH 2011). Natural ventilation is generally preferred for ventilation of residences primarily due to a mean temperature of >65 °F throughout the year (Desert Research Institute [DRI] 2013). Heating is only occasionally used in sparsely populated, high-elevation areas of the islands of Maui and Hawai'i. Although detailed studies of IAERs have not been published for the state, the annual-average IAERs can reasonably be assumed to be at least as high as those of coastal central California.

Vapor Entry Rates

Climate-Weighted Vapor Entry Rates

An overview of factors related to building leakage and vapor intrusion under different climate and ventilation scenarios is included in Appendix S1. The USEPA (2004) vapor intrusion guidance recommends a default, subsurface vapor entry rate of 5 L/min into buildings for general screening purposes (i.e., 83 cm³/s or 7200 L/d).

This rate is considered to be reasonable for conditions when advection is the dominant mechanism for vapor transport across a foundation. This value is supported both by conservative models and through comparison to radon and tracer studies (USEPA 2012a; see also CalEPA 2011). The USEPA (2012a) Conceptual Site Model document for vapor intrusion clarifies that the entry rate ("soil gas advection rate") applies to each 100 m² footprint of a building and must be proportionally corrected for building size.

The USEPA (2012a) Conceptual Site Model document notes that impacts to indoor air are relatively constant for higher vapor entry rates (e.g., >5 L/min per 100 m² footprint). Increasing the vapor entry rate will not increase impacts to indoor air. This is because VOC transport into the advective zone is limited by the rate of VOC diffusion away from the source (USEPA 2012a). A vapor entry rate of 5 L/min thus represents a reasonable maximum value.

As is the case for IAERs, annual-average vapor entry rates can be anticipated to vary across seasons and between different climate zones. Song et al. (2014) evaluated seasonal changes in vapor entry rates by linking vapor intrusion models to building leakage models, which are used to assess energy efficiency (see Sherman and Matson 2011). The models generate a worst-case indoor-outdoor pressure differential of 40 g/cm-s² for periods when a home is being heated, identical to the default value incorporated into the USEPA vapor intrusion guidance (USEPA 2004). Significantly lower pressure differentials are calculated for warmer periods of the year, with values approaching zero for summer periods when the home is being cooled.

These day-to-day pressure differentials are entered into the USEPA (2004) vapor intrusion model to estimate daily vapor entry rates. The models suggest a peak vapor entry of approximately 3 to 5 L/min (per 100 m²) during the cold winter months when a structure is being heated (Song et al. 2014). This corresponds well with the default vapor entry rate recommended by the USEPA (2004). However, vapor entry rates in the range of 0 to 2 L/min are characteristic of warm summer months, when the structure is being cooled and the pressure differential between indoor and outdoor air is significantly less. This lower entry rate corresponds well with radon field studies, which indicated a fivefold reduction in radon entry rates when a building is cooled by open windows and doors (Cavallo et al. 1992). The use of air conditioning will typically pressurize a building and largely negate the advective intrusion of subsurface vapor (ASHRAE 2009, 2013a; see also MHRA 2003; USEPA 2010, 2012; Song et al. 2014; Appendix S1). Note that this could result in the *outward* leakage of indoor air in subslab soils (McHugh et al. 2006, 2012).

Taking these studies into consideration, a default average vapor entry rate of 5 L/min is reasonably conservative for cold periods of the year, when a building is likely to be heated for at least part of the day (e.g., mean daily temperature <65 °F). Similarly, a default vapor entry rate of 2 L/min is reasonable for periods when a building is being cooled (e.g., mean daily temperature less than HDD default of 65 °F). For screening purposes, it is reasonable to apply the more conservative vapor entry rate to intermittent periods (e.g., spring and fall) when a building might be either heated

or cooled but wind effects and closed doors and windows could depressurize the structure.

Default Vapor Entry Rates for VIR Regions

This approach allows the calculation of seasonally weighted vapor entry rates based on the average number of heating days and cooling days per year for a targeted area and an appropriate temperature to approximate the cutoff for that area. Table 1 presents the approximate number of cooling days (i.e., mean daily temperature >65 °F) per year for each of the four designated climate regions. Data for the contiguous 48 states are based on Composite Temperature Plots published by the National Oceanographic and Atmospheric Administration for the years 1994 to 2013 (National Oceanographic and Atmospheric Administration [NOAA] 2013). Estimates of mean daily temperatures for Hawai'i (used as a surrogate for southernmost Florida, Puerto Rico, the United States Virgin Islands, and Guam) and Alaska are based on data published by the Desert Research Institute (DRI 2013).

The IECC cutoff of 65 °F is used to establish CDD and HDD values for Regions A, B, and D. This temperature cutoff is not appropriate for the Mediterranean climate of coastal central California. The number of days for which the mean daily temperature is below 65 °F is similar to the much colder Region A (i.e., 77 °F vs. 62 °F; refer to NOAA 2013), yet the average IAER is significantly higher. The higher IAER suggests that residents continue to keep windows open when the temperatures are below 65 °F. Heating is also less likely to be used during this period. Although somewhat subjective, an alternative cutoff of 55 °F is considered to be reasonable for the estimation of CDD vs. HDD values in Region C. As noted in Table 1, this yields a total of 166 d during which homes might be heated during the year.

Assignment of a default vapor entry rate of 2 L/min for “cooling days” and an entry rate of 5 L/min for the remaining parts of the year (i.e., heating or otherwise “non-cooling days”) generates weighted year-average vapor entry rates of 4.5, 4.0, 3.4, and 2.0 L/min for the cold, warm, Mediterranean, and tropical climate regions, respectively (see Table 1). Climate data and models similar to those published by Song et al. (2014) could be used to develop

weighted vapor entry rates on a more area-specific basis (see also USDOE 2010).

Application of Method

Estimation of VIR Region SSAFs

Default SSAFs can now be calculated and assigned to each of the VIR regions in Figure 4. The selected IAERs, vapor entry rates, and associated SSAFs are preliminary and illustrate regional differences in VIRs. A more detailed analysis similar to that of Song et al. (2014) could be carried out for individual regions or subparts of these regions. Note that the SSAF values presented may not reflect the views of regulatory agencies that oversee vapor intrusion investigations in the region, except as specifically referenced.

Region-specific IAERs assigned in terms of IAER must be converted to volume per unit time for comparison to vapor entry rates for a floor area of 100 m². Assuming a default indoor house volume of 244 m³ or 244,000 L (USEPA 2012a), conversion of the assigned IAERs of 0.35/h (VIR Region A), 0.50/h (VIR Region B), and 1.0/h (VIR Regions C and D) to liters per minute yields default IAERs of 1423, 2033, and 4067 L/min, respectively (Table 2).

Default SSAFs are generated for VIR regions using Equation 4 (Table 2). An SSAF of 0.0032 is calculated for the colder areas of VIR Region A. This agrees well with an annual-average attenuation factor of 0.003 estimated for residential buildings in northeastern states by Song et al. (2014). A slightly lower SSAF of 0.0020 is calculated for the warmer areas of VIR Region B. An SSAF of 0.0008 is calculated for VIR Region C, the Mediterranean climate areas of coastal California with its cool summers. The lowest SSAF of 0.0005 is calculated for VIR Region D, including the tropical islands of Hawai'i, southernmost Florida, Puerto Rico, the United States Virgin Islands, and Guam.

The range of attenuation factors predicted agrees well with previous estimates of SSAFs based on estimated vapor entry rates and IAERs (e.g., USEPA 2004). The region boundaries depicted in Figure 4 could be evaluated at a more local scale by referring to the IECC Climate Zone database (ICC 2012; see also ASHRAE 2010 and USDOE 2010) and Köppen-Geiger and Trewartha climate-classification maps

Table 2
Subslab Attenuation Factors Estimated for Designated Vapor Intrusion Risk Regions

Climate Zone ¹	Default Vapor Entry Rate ² (L/min)	Default Indoor Air Exchange Rate ³ (L/min)	Subslab Attenuation Factor ⁴	
Region A (Cold) ⁵	4.5	0.35/h	1423	0.0032
Region B (Warm) ⁶	4.0	0.5/h	2033	0.0020
Region C (Mediterranean) ⁷	3.4	1.0/h	4067	0.0008
Region D (Tropical) ⁸	2.0	1.0/h	4067	0.0005

¹Vapor intrusion risk regions (see Figure 4).

²Annual-average vapor entry rate (see Table 1).

³Reflects assumed interior house volume of 244 m³ and default building slab (or crawl space) area of 100 m².

⁴Ratio of vapor entry rate to indoor air exchange rate.

⁵Cold climate region represented by northern and Rocky Mountain states with mean daily temperature >65 °F from at least July through August.

⁶Warm climate region represented by southern and southwestern states with mean daily temperature >65 °F from at least June through September.

⁷Mediterranean climate region represented by coastal central California with cool summers and mean daily temperature >55 °F from mid-April through October.

⁸Tropical climate region represented by Hawai'i, southernmost Florida, Puerto Rico, the United States Virgin Islands, and Guam, with year-round mean daily temperature >65 °F.

(e.g., Trewartha and Horn 1980; Peel et al. 2007) as well as local building leakage studies. The mean daily temperature across much of the Gulf Coast, for example, exceeds 65 °F during the months of April and October, while temperatures are still well below this level for more northern areas of the “warm” climate region during these months. A lower number of heating days and ultimately a lower SSAF would be warranted for these areas in comparison to the rest of the warm climate region.

Alaska is included in the same climate region as Iowa, even though the mean daily temperature across the majority of Alaska never exceeds 65 °F. The overall SSAF of 0.0032 generated for Region A might, therefore, be insufficiently conservative for this state, but it is close to a maximum SSAF value of 0.0035, due to a vapor entry rate of 5 L/min and an IAER of 0.35/h.

Comparison to Database-Derived SSAFs

The discrepancies between the above-estimated default SSAFs and those extracted from the USEPA (2012b) empirical database (e.g., 95th percentile SSAF) are tied to several factors, including: (1) error in the database associated with spatial (and temporal) subslab vapor heterogeneity, (2) error in the database associated with masking of low but probably typical SSAFs due to interference from indoor air sources of VOCs, and (3) attempts to develop a single IAER, vapor entry rate, and SSAF for the highly variable climate regions of the United States. The conflict is recognized but not fully reconciled in the database report:

Using the median values for residential building volume and air exchange rates (395 m³ and 0.45 air changes per hour, respectively) provided in the *Exposure Factors Handbook 2011 Edition ...* and a central value of 5 L/min for Q_{soil} in sandy materials ... the median value of the subslab soil gas attenuation factor ... is expected to be approximately 0.002. (USEPA 2012b, 50)

The CalEPA (2011) vapor intrusion guidance recommends a default SSAF of 0.05 for California as a whole, based on earlier interpretation of the USEPA database. This SSAF suffers from the same problems as aforementioned for more recent interpretations of the USEPA (2012b) database. The same guidance, however, recommended a default vapor entry rate, house volume, and an IAER of 5 L/min, 244 m³, and 0.5/h, respectively, for a more site-specific evaluation of existing or future residential buildings. This generates a more technically defensible SSAF of 0.0025 and corresponds well to the default SSAF of 0.0020 estimated in this paper for VIR Region B (see Table 2).

Oregon was likewise cautious regarding the seemingly high 95th percentile SSAF of 0.03 proposed for the USEPA (2012b) database. An SSAF of 0.005, closer to the median of the database, was ultimately selected for inclusion in that state’s vapor intrusion guidance (ORDEQ 2010).

Limitations

The IAERs and vapor entry rates assigned to individual regions for calculation of generic SSAFs cannot be assumed to be applicable to individual buildings as part of a site-specific vapor intrusion investigation. Vapor entry rates and IAERs,

as well as SSAFs, can vary significantly both between and within buildings (see Appendix S1; see also Johnson 2002, 2005). IAERs are well studied but could vary by an order of magnitude, depending on the age and design of the structure; the method being used for heating, cooling, and ventilation; and other factors (Appendix S1). Effective vapor entry rates can vary by wide margins for similar reasons, including the presence or absence of floor cracks and gaps in different areas of an individual building. Site-specific measurement of vapor flow into buildings and IAERs is difficult if not impossible for typical vapor intrusion investigations.

However, potential error associated with building-specific variability of IAERs and vapor entry rates does not necessarily carry over to estimation of annual-average SSAFs. Long-term vapor entry rates and IAERs are positively correlated. Although sufficient quantitative field data are still lacking, especially for “ Q_{soil} ,” an increase in the vapor entry rate should be accompanied by an offsetting increase in the IAER (see Cavallo et al. 1992; Song et al. 2014; see also Hers et al. 2001). This relationship and the use of reasonably conservative values for both parameters minimize the risk that the generic SSAFs could significantly underpredict the magnitude of long-term vapor intrusion impacts to indoor air.

The applicability of the generic SSAFs presented in this paper to short-term impacts to indoor air (e.g., intraday) is uncertain. Short-term temporal and/or spatial variability of both IAERs and vapor entry rates could be significant due to sudden changes in weather conditions (e.g., high winds) or changes in building ventilation (e.g., heating or air conditioning turned off at night). This could affect short-term SSAFs and lead to temporarily decreased or increased impacts to indoor air. A detailed evaluation of the short-term variability of impacts to indoor air related to vapor intrusion was, however, beyond the scope of this paper.

Summary and Conclusions

This paper illustrates that the disparity between the two approaches for estimation of SSAFs is most likely attributable to error associated with individual data points incorporated into the USEPA (2012b) empirical database. Spatial variability in subslab soil gas, uncertainty in vapor entry points, and the limited number of sample points per structure (typically one) introduces unavoidable and unquantifiable error into the calculated SSAFs. Temporal and spatial variability of VOCs in indoor air, the potential for unrecognized indoor sources of VOCs, and the limited number of sample points (again typically one) per structure introduce additional and unquantifiable error. Statistical analysis of the data does not solve this problem and merely assesses the variability between individual homes and buildings rather than the potential error associated with individual building data points.

These irresolvable problems invalidate the use of the USEPA (2012b) vapor intrusion database for development of defensible and reproducible SSAFs within a reasonable degree of accuracy. Error associated with the representativeness of subslab soil gas data and/or indoor air data in the USEPA VI database is directly carried over into calculation of an SSAF, and it is impossible to assess on a building-specific basis. The potential variability of VOC concentrations in

vapor plumes alone suggests that error could exceed two orders of magnitude for an individual building.

A similar conclusion was drawn by Yao et al. (2013a) after a more detailed review of data trends and uncertainty regarding potential error associated with indoor air concentrations used to estimate attenuation factors. In particular, estimates of SSAFs based on the 95th percentile of the database could simply represent this level of disparity between signal and noise in indoor and subsurface vapor concentrations. The median ratio of VOCs in indoor air to subsurface soil gas extracted from the database (0.003, similar to the apparent mode) is similar to the SSAF value estimated in this paper for the same area of the country (VIR Region A; 0.0032). Whether this is coincidental or real is impossible to evaluate, however, given the uncertainty in the representativeness of the individual data points in the database. If accurate, then deviations away from this SSAF value in the database (i.e., above or below the median) could simply reflect increasing error in the data.

Uncertainty and error associated with the calculation of SSAFs from reasonably conservative vapor entry rates and IAERs are considerably lower. This approach, already incorporated into the USEPA (2004) vapor intrusion models and numerous state guidance documents, is more practical and technically defensible for development of region-specific SSAFs and screening levels. The approach also allows for estimation of region-specific SSAFs based on climate data, building designs, and heating and cooling needs, rather than applying a single, generic SSAF to the country as a whole. Default IAERs used to estimate generic SSAFs are considered to be reasonably conservative and reflect either values currently used by individual states for vapor intrusion guidance or the minimum rates required for building ventilation. Climate-weighted, vapor entry rates are conservatively biased to reflect upper limits on diffusive VOC transport away from source areas. Error is most likely to be associated with *overestimation* of potential, long-term vapor intrusion impacts, especially in areas where buildings are air conditioned for most of the year and over pressurization of lower floors negates significant subsurface vapor entry.

This paper also emphasizes the need to understand seasonal variability in building ventilation mechanics as an essential part of vapor intrusion studies. For example, more site-specific studies might consider a lower average subsurface vapor flow into buildings due to reduced or even negative flow during periods when the building is air conditioned and pressurized. The associated flow of indoor air into subsurface soil during these periods also has implications for both the collection of subsurface soil vapor samples and the estimation of the vapor attenuation (e.g., McHugh et al. 2006, 2012; USEPA 2012b). Misinterpretation of the cause of low VOC concentrations beneath a slab could lead to erroneously high estimates of upward vapor attenuation due to natural degradation processes, as well as mistaken assumptions regarding the presence of a permanent, well-oxygenated zone beneath the slab that could be absent when the building is heated. Potential variability in building pressurization supports the need to collect subsurface soil gas over different seasons to assess conditions when the building might be under positive, neutral, or negative pressure. The resulting data can be used to assess VIR averaged over the year.

Assessment of VOC concentrations in targeted areas beneath a slab is still feasible, in spite of the problems caused by larger scale variability in subsurface vapor. The variability of VOC concentrations in vapors within any given subarea beneath a slab is likely to be relatively low in comparison to variability across the slab as a whole, due to the diffusive properties of the chemicals. Recommendations to collect soil gas data from the center of a building in the area of the highest anticipated vapor concentration, between the center and the suspected source, and near vapor entry points (e.g., utility gaps in the downwind side of the slab) seem reasonable for screening-level vapor intrusion investigations (e.g., ORDEQ 2010; CalEPA 2011; USEPA 2012a; Yao et al. 2013b; see also Luo et al. 2009). Whether these vapors are representative of vapors actually intruding into the building is probably unknowable with any degree of certainty. The representativeness of subsurface data from these areas will improve as more cost-effective methods for the collection of a larger number of samples or larger sample volumes from targeted areas continue to be developed.

Acknowledgments

The authors wish to acknowledge the numerous environmental consultants and regulators who provided input and often lively debate during preparation of this paper. Special thanks is given to Uta Hellmann-Blumberg and Ross Steenson for their reviews and input on multiple drafts of the manuscript. The authors also thank the reviewers of the final manuscript for their help in making the presentation of this complex issue as concise as possible. The conclusions expressed in the paper are, however, our own and may not necessarily reflect those of the reviewers.

Disclaimer

Guidance published by the Hawai'i Department of Health and referenced in this paper was funded partly through the use of U.S. EPA State Response Program Grant funds. Its contents do not necessarily reflect the policies, actions, or positions of the U.S. Environmental Protection Agency. The Hawai'i Department of Health does not speak for or represent the U.S. Environmental Protection Agency.

There are no known conflicts of interest or financial interests associated with this manuscript.

Supporting Information

The following supporting information is available for this article:

Appendix S1. Overview of indoor air exchange rates and vapor intrusion and building leakage.

Additional Supporting Information may be found in the online version of this article.

References

- American Petroleum Institute (API). 2005. *Collecting and Interpreting Soil Gas Samples from the Vadose Zone A Practical Strategy for Assessing the Subsurface Vapor-to-Indoor Air Migration Pathway at Petroleum Hydrocarbon Sites*, Publication no. 4741. Washington, DC: API.

- American Society of Heating, Refrigerating and Air-Conditioning Engineers (ASHRAE). 2013a. *Handbook of Fundamentals*. Atlanta, Georgia: ASHRAE.
- American Society of Heating, Refrigerating and Air-Conditioning Engineers (ASHRAE). 2013b. *Ventilation for Acceptable Indoor Air Quality*. Standard 62.1. Atlanta, Georgia.
- American Society of Heating, Refrigerating and Air-Conditioning Engineers (ASHRAE). 2010. *Ventilation and Acceptable Indoor Air Quality in Low-Rise Residential Buildings*. Standard 62.2. Atlanta, Georgia.
- American Society of Heating, Refrigerating and Air-Conditioning Engineers (ASHRAE). 2009. *ASHRAE Handbook - Fundamentals*. Atlanta, Georgia: ASHRAE.
- American Society of Heating, Refrigerating and Air-Conditioning Engineers (ASHRAE). 2006. *A Method of Determining Air Change Rates in Detached Dwellings*. Standard 136-1993 (RA 2006). Atlanta, Georgia.
- American Society of Heating, Refrigerating and Air-Conditioning Engineers (ASHRAE). 2002. *Measuring Air Change Effectiveness*. Standard 129-1997 (RA 2002). Atlanta, Georgia.
- American Society for Testing and Materials (ASTM). 2011. *Standard Practice for Passive Soil Gas Sampling in the Vadose Zone for Source Identification, Spatial Variability Assessment, Monitoring, and Vapor Intrusion Evaluations*, ASTM D7758-11. West Conshohocken, Pennsylvania.
- American Society for Testing and Materials (ASTM). 2000. *Standard Test Method for Determining Air Change in a Single Zone by Means of a Tracer Gas Dilution*, ASTM E741-00. West Conshohocken, Pennsylvania.
- American Society for Testing and Materials (ASTM). 1990. Tracer gas techniques. *Air Change Rate and Air Tightness in Buildings*, STP:1067, ed. M.H. Sherman. Philadelphia, Pennsylvania: ASTM.
- Batterman, S., C. Jia, G. Hatzivasilis, and C. Godwin. 2006. Simultaneous measurement of ventilation using tracer gas techniques and VOC concentrations in homes, garages and vehicles. *Journal of Environmental Monitoring* 8: 249–256.
- Bennett, D.H., W. Fisk, M.G. Apte, X. Wu, A. Trout, D. Faulkner, and D. Sullivan. 2012. Ventilation, temperature, and HVAC characteristics in small and medium commercial buildings in California. *Indoor Air* 22: 309–320.
- Brewer, R., J. Nagashima, M. Kelley, and M. Rigby. 2013. Risk-based evaluation of total petroleum hydrocarbons in vapor intrusion studies. *International Journal of Environmental Research and Public Health* 10: 2441–2467.
- Bunzl, K., F. Ruckerbauer, and R. Winkler. 1998. Temporal and small-scale spatial variability of 222Rn gas in a soil with a high gravel content. *The Science of the Total Environment* 220: 157–166.
- California Energy Commission (CEC). 2001. Manual for Compliance with the 2001 *Energy Efficiency Standards (for Nonresidential Buildings, High-Rise Residential Buildings, and Hotels/Motels)*, Document No. P400-01-032.
- California Environmental Protection Agency (CalEPA), Department of Toxic Substances Control (in conjunction with the California Regional Water Quality Control Board, Los Angeles Region). 2012. *Advisory – Active Soil Gas Investigations*. Los Angeles, California: CalEPA.
- California Environmental Protection Agency (CalEPA), Department of Toxic Substances Control. 2011. *Guidance for the Evaluation and Mitigation of Subsurface Vapor Intrusion to Indoor Air*. Sacramento, California: CalEPA.
- California Environmental Protection Agency (CalEPA), Regional Water Quality Control Board, San Francisco Bay Area Region. 2008. *Screening for Environmental Concerns at Sites with Contaminated Soil and Groundwater*. Oakland, California: CalEPA.
- Cavallo, A., K. Gadsby, T.A. Reddy, and R. Socolow. 1992. The effect of natural ventilation on radon and radon progeny levels in houses. *Radiation Protection Dosimetry* 45: 569–573.
- Choi, J.W., and J.A. Smith. 2005. Geoenvironmental factors affecting organic vapor advection and diffusion fluxes from the unsaturated zone to the atmosphere under natural conditions. *Environmental Engineering Science* 22: 95–108.
- Desert Research Institute (DRI). 2013. *Average Statewide Temperature for Western U.S. States*. Reno, Nevada: Western Regional Climate Center.
- Dodson, R.E., J.I. Levy, J.P. Shine, J.D. Spengler, and D.H. Bennett. 2007. Multi-zonal air flow rates in residences in Boston, Massachusetts. *Atmospheric Environment* 41: 3722–3727.
- Eklund, B.M., S. Burkes, P. Morris, and L. Mosconi. 2008. Spatial and temporal variability in VOC levels within a commercial retail building. *Indoor Air* 18: 365–374.
- Folkes, D., W. Wertz, J. Kurtz, and T. Kuehster. 2009. Observed spatial and temporal distributions of CVOCs at Colorado and New York vapor intrusion sites. *Ground Water Monitoring and Remediation* 29, no. 1: 70–80.
- Gilbert, N.L., M. Guaya, D. Gauvinb, R.N. Dietz, C.C. Chand, and B. Levesque. 2008. Air change rate and concentration of formaldehyde in residential indoor air. *Atmospheric Environment* 42: 2424–2428.
- Hawaii Department of Health (HDOH), Office of Hazard Evaluation and Emergency Response. 2011. *Evaluation of Environmental Hazards at Sites with Contaminated Soil and Groundwater*. Honolulu, Hawaii: HDOH.
- Hers, I., R. Zapf-Gilje, L. Li, and J. Atwater. 2001. The use of indoor air measurements to evaluate intrusion of subsurface VOC vapors into buildings. *Journal of the Air & Waste Management Association* 51: 1318–1331.
- Holton, C., H. Luo, P. Dahlen, K. Gorder, E. Dettenmaier, and P.C. Johnson. 2013. Temporal variability of indoor air concentrations under natural conditions in a house overlying a dilute chlorinated solvent groundwater plume. *Environmental Science and Technology* 47: 13347–13354.
- International Code Council (ICC). 2012. *International Energy Conservation Code and Commentary*. Washington, DC: ICC.
- Interstate Technology & Regulatory Council (ITRC). 2007. *Vapor Intrusion Pathway: A Practical Guideline*. Washington, DC: ITRC.
- Interstate Technology & Regulatory Council (ITRC). 2005. *Examination of Risk-Based Screening Values and Approaches of Selected States*. Washington, DC: ITRC.
- Johnson, P.C. 2005. Identification of application-specific critical inputs for the 1991 Johnson and Ettinger vapor intrusion algorithm. *Groundwater Monitoring & Remediation* 25, no. 1: 63–78.
- Johnson, P.C. 2002. *Identification of Critical Parameters for the Johnson and Ettinger (1991) Vapour Intrusion Model*. American Petroleum Institute Technical Bulletin No. 17. Washington, DC.
- Johnson, P.C., H. Luo, C. Holton, D. Dahlen, and Y. Guo. 2012. *Integrated Field-Scale, Lab-Scale, and Modeling Studies for Improving the Ability to Assess the Groundwater to Indoor Air Pathway at Chlorinated Solvent-Impacted Groundwater Sites*. Alexandria, Virginia: Department of Defense Strategic Environmental Research and Development Program.
- Kauffman, E. 2003. Climate and topography. In *Atlas of the Biodiversity of California*, ed. M. Parisi, 12–15. Sacramento, California: California Department of Fish and Wildlife.
- Lawrence Berkeley National Laboratory (LBNL). 1998. *Recommended Ventilation Strategies for Energy-Efficient Production Homes*. Berkeley, California: Lawrence

- Berkeley National Laboratory, Energy Analysis Department, Environmental Energy Technologies Division.
- Luo, H., P. Dahlen, P.C. Johnson, T. Peargin, and T. Creamer. 2009. Spatial variability of soil-gas concentrations near and beneath a building overlying shallow petroleum hydrocarbon impacted soils. *Groundwater Monitoring & Remediation* 29, no. 1: 81–91.
- Lutes, C., C. Cosky, R. Uppencamp, L. Abreu, B. Schumacher, J. Zimmerman, R. Truesdale, S.Y. Lin, H. Hayes, and B. Hartman. 2012. Recent observations on spatial and temporal variability in the field. Abstract presented at the Annual Meeting for 22nd Annual International Conference on Soil, Water, Energy, and Air. San Diego, California.
- Manufactured Housing Research Alliance (MHRA). 2003. *Whole House Ventilation Strategies*. New York: MHRA.
- McHugh, T.E., L. Beckley, D. Bailey, K. Gorder, E. Dettenmaier, I. Rivera-Duarte, S. Brock, and I.C. MacGregor. 2012. Evaluation of vapor intrusion using controlled building pressure. *Environmental Science and Technology* 46: 4792–4799.
- McHugh, T.E., T.N. Nickels, and S. Brock. 2007. Evaluation of spatial and temporal variability in VOC concentrations at vapor intrusion investigation sites. In *Proceedings of Air and Waste Management Association. Vapor Intrusion: Learning from the Challenges*, September 26–28, Providence, Rhode Island, 129–142.
- McHugh, T.E., P.C. De Blanc, and R.J. Pokluda. 2006. Indoor air as a source of VOC contamination in shallow soils below buildings. *Soil & Sediment Contamination* 15: 103–122.
- Murray, D.M., and D.E. Burmaster. 1995. Residential air exchange rates in the United States: Empirical and estimated parametric distribution by season and climatic region. *Risk Analysis* 15, no. 4: 459–465.
- National Oceanographic and Atmospheric Administration (NOAA). 2013. *Composite Temperature Plots*. Washington, DC: NOAA, Earth System Research Laboratory, Physical Sciences Division.
- New Jersey Department of Environmental Protection (NJDEP), Site Remediation and Waste Management Program. 2013. *Vapor Intrusion Technical Guidance*. Trenton, New Jersey.
- Oakland Environmental Services Division (OESD). 2000. *Technical Background Document*. Oakland, California: OESD.
- O'Neill, H. 2013. Advanced passive soil gas sampling – Collection of high resolution site characterization data. Abstract presented at the Annual Meeting for CleanUp 2013 – 5th International Contaminated Site Remediation Conference, September 18, Melbourne, Australia.
- Oregon Department of Environmental Quality (ORDEQ), Environmental Cleanup Program. 2010. *Guidance for Assessing and Remediating Vapor Intrusion in Buildings*. Portland, Oregon: ORDEQ.
- Otson, R., and P. Fellin. 1992. Volatile organics in the indoor air environment, sources and occurrence. In *Gaseous Pollutants, Characterization and Cycling*, ed. J.O. Nriagu, 335–421. New York: John Wiley and Sons.
- Peel, M.C., Finlayson, B.L., and T.A. McMahon. 2007. Updated world map of the Köppen-Geiger climate classification. *Hydrology and Earth System Sciences* 11: 1633–1644.
- Schmidt, M.A. 2012. Innovative sampling methods for focusing the subslab soil-gas investigation. Paper presented at the Annual Meeting for Air Quality Measurement Methods and Technology, April 24–26, Durham, North Carolina.
- Shen, R., Y.J. Yao, K.G. Pennell, and E.M. Suuberg. 2013. Modeling quantification of the influence of soil moisture on subslab vapor concentration. *Environmental Science: Processes & Impacts* 15: 1444–1451.
- Sherman, M.H. 1995. The use of blower door data. *Indoor Air* 5: 215–224.
- Sherman, M., and N. Matson. 2011. *Residential Ventilation and Energy Characteristics*. Berkeley, California: Lawrence Berkeley National Laboratory, Energy Performance of Buildings Group, Energy and Environment Division.
- Silver, N. 2012. *The Signal and the Noise: Why So Many Predictions Fail—But Some Don't*. New York: The Penguin Press.
- Song, S., B.A. Schnorr, and F.C. Ramacciotti. 2014. Quantifying the influence of stack and wind effects on vapor intrusion. *Human and Ecological Risk Assessment* 20: 1345–1358.
- Song, S., F.C. Ramacciotti, B.A. Schnorr, M. Bock, and C.M. Stubbs. 2011. Evaluation of USEPA's empirical attenuation factor database. *Air Waste and Management Association. Emissions Monitoring* February 2011: 16–21.
- Taylor, G.H., and C. Hannan. 1999. *The Climate of Oregon, From Rain Forest to Desert*. Corvallis, Oregon: Oregon State University Press.
- Tillman, F.D., and J.W. Weaver. 2006. Uncertainty from synergistic effects of multiple parameters in the Johnson and Ettinger (1991) vapor intrusion model. *Atmospheric Environment* 40: 4098–4112.
- Trewartha, G.T., and L.H. Horn. 1980. *An Introduction to Climate*, 5th ed. New York: McGraw-Hill.
- U.S. Department of Energy (USDOE), Energy Efficiency and Renewable Energy, Building Technologies Program. 2010. *Guide to Determining Climate Regions by County*. Washington, DC: USDOE.
- U.S. Department of Defense (USDOD), Air Force Institute for Operational Health, Health Risk Assessment Branch. 2009. *DoD Vapor Intrusion Handbook*. Washington, DC: USDOD.
- U.S. Department of Energy (USDOE), Building Technologies Program, Office of Energy Efficiency and Renewable Energy. 2002. *Spot Ventilation - Source Control to Improve Indoor Air Quality (Technology Fact Sheet)*. Washington, DC: USDOE.
- U.S. Environmental Protection Agency (USEPA), Office of Solid Waste and Emergency Response. 2012a. *Conceptual Model Scenarios for the Vapor Intrusion Pathway*. EPA 530-R-10-003. Washington, DC: USEPA.
- U.S. Environmental Protection Agency (USEPA), Office of Solid Waste and Emergency Response. 2012b. *EPA's Vapor Intrusion Database: Evaluation and Characterization of Attenuation Factors for Chlorinated Volatile Organic Compounds and Residential Buildings*. EPA 530-R-10-002. Washington, DC: USEPA.
- U.S. Environmental Protection Agency (USEPA), Office of Research and Development, National Center for Environmental Assessment. 2011. *Exposure Factors Handbook*. EPA/600/R-090/052F. Washington, DC: USEPA.
- U.S. Environmental Protection Agency (USEPA), Office of Radiation and Indoor Air, Indoor Environments Division. 2010. *Building Codes and Indoor Air Quality*. Washington, DC: USEPA.
- U.S. Environmental Protection Agency (USEPA), Indoor Environments Division. 2007a. *Exploratory Study of Basement Moisture during Operation of ASD Radon Control Systems* (revised March 2008). Washington, DC: USEPA.
- U.S. Environmental Protection Agency (USEPA), Office of Research and Development, National Exposure Research Laboratory, Environmental Sciences Division. 2007b. *Final Project Report for Investigation of the Influence of Temporal Variation on Active Soil Gas/Vapor Sampling*. EPA/600/R-07/141. Las Vegas, Nevada: USEPA.

- U.S. Environmental Protection Agency (USEPA), Office of Emergency and Remedial Response. 2004. *User's Guide for Subsurface Vapor Intrusion into Buildings*. Washington, DC: USEPA.
- U.S. Environmental Protection Agency (USEPA), Office of Solid Waste and Emergency Response. 2002. *Draft Guidance for Evaluating the Vapor Intrusion to Indoor Air Pathway from Groundwater and Soils (Subsurface Vapor Intrusion Guidance)*. Washington, DC: USEPA.
- Whetzel, J., H. Anderson, and J. Hodny. 2009. Spatial and temporal variability in vapor intrusion investigations. Abstract presented at the Annual Meeting for USEPA National Forum on Vapor Intrusion, January 12–13, Philadelphia, Pennsylvania, 2009.
- Widdowson, M.A., O.R. Haney, H.W. Reeves, C.M. Aelion, and R.P. Ray. 1997. Multiple soil-vapor extraction test for heterogeneous soil. *Journal of Environmental Engineering* 123: 160–168.
- Wilson, A.L., S.D. Colome, Y. Tian, E.W. Beck, P.E. Baker, D.W. Behrens, I.H. Billick, and C.A. Garrison. 1996. California residential air exchange rates and residence volumes. *Journal of Exposure Analysis and Environmental Epidemiology* 6, no. 3: 311–326.
- Winkler, R., F. Ruckerbauer, and K. Bunzl. 2001. Radon concentration in soil gas: A comparison of the variability resulting from different methods, spatial heterogeneity and seasonal fluctuations. *The Science of the Total Environment* 272: 273–282.
- Yamamoto, N., D.G. Shendell, A.M. Winter, and J. Zhang. 2010. Residential air exchange rates in three U.S. metropolitan areas: Results from the relationship among indoor, outdoor, and personal air study 1999–2001. *Indoor Air* 20: 85–90.
- Yao, Y.J., R. Shen, K.G. Pennell, and E.M. Suuberg. 2013a. Examination of the U.S. EPA's vapor intrusion database based on models. *Environmental Science and Technology* 47, 1425–1433.
- Yao, Y.J., R. Shen, K.G. Pennell, and E.M. Suuberg. 2013b. Examination of the influence of environmental factors on contaminant vapor concentration attenuation factors using the U.S. EPA's vapor intrusion database. *Environmental Science and Technology* 47: 906–913.
- Yao, Y.J., K.G. Pennell, and E.M. Suuberg. 2013c. Simulating the effect of slab features on vapor intrusion of crack entry. *Building and Environment* 59: 417–425.

Biographical Sketches

Roger Brewer, corresponding author, is at the Hawaii Department of Health, 919 Ala Moana Blvd., Room 206, Honolulu, HI 96814; +1-808-586-4249; fax +1-808-586-7537; roger.brewer@doh.hawaii.gov

Josh Nagashima is at the Hawaii Department of Health, 919 Ala Moana Blvd., Room 206, Honolulu, HI 96814; josh.nagashima@doh.hawaii.gov

Mark Rigby is at Parsons Corporation, 10235 South Jordan Gateway, Suite 300, South Jordan, UT 84095. He may be reached at Marine Science Institute and the Department of Ecology, Evolution, and Marine Biology, University of California, Santa Barbara, CA 93106. mark.rigby@parsons.com

Martin Schmidt is at Cox-Colvin and Associates, Inc., 7750 Corporate Blvd, Plain City, OH 43064; mort_schmidt@coxcolvin.com

Harry O'Neill is at Beacon Environmental Services, Inc., 2203A Commerce Road, Suite 1, Forest Hill, MD 21050; Harry.ONeill@beacon-usa.com

Congratulations to the 2014 winners of NGWA awards spotlighting the best and the brightest in the groundwater industry!



NGWA Awards of Excellence

- Ross L. Oliver — W. Richard Laton, Ph.D., PG, CHG, CPG
- M. King Hubbert — Fred Molz, Ph.D.
- Life Members — Henry "Hank" Baski, Richard "Dick" Henkle and, Steven P. Maslansky
- Technology — James Rumbaugh
- Special Recognition — Ralph Cadwallader (posthumously) and Miami Conservancy District
- Groundwater Protector — U.S. Senator Rob Portman (R-Ohio)
- Standard Bearer — Beverly L. Herzog

Outstanding Groundwater Project Award

- Groundwater Remediation — Essential Management Solutions LLC

NGWA Divisional Awards

- John Hem (Scientists and Engineers Division) — Paul Barlow, Ph.D., and Stanley Leake
- Keith E. Anderson (Scientists and Engineers Division) — W. Richard Laton, Ph.D., PG, CHG, CPG
- Manufacturers Division Special Recognition — Kris Jackson
- Supplier of the Year — Mark Durham



www.NGWA.org/Awards

Supplement - Estimation of Subslab Attenuation Factors for Vapor Intrusion Investigations

Roger Brewer^{1*}, Josh Nagashima¹, Mark Rigby^{2,3}, Martin Schmidt⁴ and Harry O'Neill⁵

¹ Hawaii Department of Health, 919 Ala Moana Blvd., Room 206, Honolulu, HI 96814, USA; E-Mail: roger.brewer@doh.hawaii.gov, josh.nagashima@doh.hawaii.gov

² Parsons Corporation, 10235 South Jordan Gateway, Suite 300, South Jordan, UT 84095, USA; E-Mail: mark.rigby@parsons.com

³ Marine Science Institute and the Department of Ecology, Evolution, and Marine Biology, University of California, Santa Barbara, California 93106

⁴ Cox-Colvin and Associates, Inc., 7750 Corporate Blvd, Plain City, OH 43064; Email: mort_schmidt@coxcolvin.com

⁵ Beacon Environmental Services, Inc., 2203A Commerce Road, Suite 1, Forest Hill, MD 21050; Email: Harry.ONeill@beacon-usa.com

* Author to whom correspondence should be addressed: E-Mail:

roger.brewer@doh.hawaii.gov;

Tel: +1-808-586-4249; Fax: +1-808-586-7537

1.0 Overview of Indoor Air Exchange Rates

1.1 Published Studies

Indoor air exchange takes place by a combination of three processes: 1) Leakage of outdoor air into the structure around windows, doors and rooflines and through cracks, gaps and other openings; 2) Natural ventilation via open windows, doors, and other openings; and 3) Forced or mechanical ventilation where the flow of fresh air into the building is driven by fans. IAER can be measured in the field using tracer tests (e.g., ASTM 1990; ASTM 2000; ASHRAE 2002, 2006, 2013a; Batterman et al. 2006; Bennett 2012). Regional variations in IAER can be predicted by models that consider the types and sizes of houses, typical leakage properties, and representative weather conditions (e.g., Sherman and Matson 2011).

Field studies conducted in the 1970s through the 1990s attempted to quantify natural infiltration rates for manufactured homes (MHRA 2003). The results of these studies suggested an average IAER of 0.25 air changes per hour under natural conditions, i.e., natural leakage due to indoor-outdoor pressure differentials and in the absence of mechanical venting to bring in outdoor air. A default IAER of 0.25/hour is also indicated by the 2004 edition of the USEPA vapor intrusion guidance document for general screening purposes (USEPA 2004).

A number of subsequent, more detailed studies based on field measurements of IAER have been published for different areas of the country (e.g., Nazaroff et al. 1988; Koontz and Rector 1995; Murray and Burmaster 1995; Wilson et al. 1996; Pandian et al. 1998; Yamamoto et al. 2010). Summaries of key studies are provided in work published by the USEPA (Hers et. al 2001; USEPA 2004, 2011; see also Johnson 2002, 2005; ASHRAE 2009, 2013a) and Lawrence Berkeley National Laboratory (Chan et al. 2005). Measured IAER vary from region to region, based in part on climate, building tightness and building ventilation

methods. Murray and Burmaster (1995) estimated regional IAER using contour maps of heating and cooling days used for designing ventilation systems for residential buildings across the country and summarized IAER for each region (see also USEIA 2003, USEPA 2011). Annual, median residential IAERs range from 0.32/hour in the northern, border states and the Rocky Mountain area to 0.65/hour for the deep south and southwest. An annual, median IAER of 0.51/hour was estimated for the US overall with slightly higher mean values.

Differences in regional IAERs were primarily due to variations in heating, air conditioning and open windows and doors throughout the year, as well regional differences in the age, design, and tightness of buildings. The use of open doors and windows for cooling during longer periods of the year can also increase the IAER by a factor of three or more (Wallace et al. 2002; Marr et al. 2012; Bennett et al. 2012). Exhaust fans will depressurize the house and similarly increase leakage of outdoor air and the overall IAER (MHRA 2003; USEPA 2010).

More recent studies suggest that IAERs in the humid southeast may have decreased in the past several decades time due to newer and tighter homes and the increased use of air conditioning (e.g., Chan et al. 2005; Breen et al. 2010; Yamamoto et al. 2010). Over pressurization of houses by air conditioning can reduce fresh air flow into a house. Commercial buildings can similarly be expected to be under positive pressure when air conditioned, as well as requirements for continual fresh air intake (MHRA 2003; USEPA 2012). As discussed below, this should coincide with a significant decrease or even elimination of vapor intrusion into the building.

A decrease in weather-induced leakage for newer homes in warm areas of the country is supported by house-leakage and energy-use models (Sherman and Matson 2011). The models were designed to assess energy efficiency during periods when being mechanically heated and cooled. County-specific, average leakage and air exchange rates for residential homes are estimated based on average house age and design, published leakage data and regional weather conditions. The models do not consider natural ventilation through open doors and windows, since this was not the point of the study. Mechanical ventilation (e.g., attic fans) is likewise not considered, since residential heating and cooling systems are also not typically designed to introduce outdoor air into the home (ASHRAE 2009, 2013a; see also Persily et al. 2010). Predicted air exchange is instead due entirely to leakage around closed doors and windows and other gaps in the walls and roofline.

The Sherman and Matson (2011) study estimates a year-average, nationwide air exchange rate due entirely to building leakage of 1.09/hour. Due to a combination of greater home tightness and expanded use of air conditioning throughout the year, however, the study predicted lower, annual air exchange rates for southeastern areas of the country (<0.8/hour to 1.0/hour) in comparison to the north and the Rocky mountains (1.0/hour to 1.5/hour). A significant, regional variation in leakage-related, air exchange rates for residential homes was not predicted by a similar modeling exercise by Persily et al. (2010), however. That study focused on 19 cities in different areas of the United States. Estimated annual-average air exchange rates ranged from 0.4/hour to 0.5/hour.

Measured IAERs that consider increased ventilation during periods when doors and windows are left open for cooling differ from the model simulations. Natural ventilation can be significant during the spring and fall season in the south and likely explains the higher, year-average IAERs measured for warmer areas of the country than predicted by leakage models. The same inconsistency between simulated and measured air exchange rates noted

for California and again is likely due to the omission of natural ventilation effects in the models. The apparent conflict between the relatively high IAERs predicted by Sherman and Matson (2011) for northern states and the Rocky mountain area in comparison to measured IAERs is unclear.

Studies specific to California derived a range of IAERs from 0.5 to 1.5 times per hour (e.g., Wilson et al. 1996). The California Department of Toxic Substances Control (DTSC), one of several entities in the state that publishes vapor intrusion guidance, selected a default IAER for residential structures of 0.5/hour for general use in the climatically diverse state (CalPA 2011). This represents the 25th percentile IAER of houses in California estimated in earlier studies (CEC 2001). The DTSC guidance states that this can be re-evaluated on a site-specific basis but does not provide specific methods to do so. More recently, Yamamoto et al. (2010) estimated the median IAER of houses in California at 0.87/hr.

The DTSC guidance recommends a default IAER of 1.0 hour for commercial buildings. This is based upon the minimal ventilation requirements for commercial facilities in California and is similar to the median value for office buildings in a study carried out by the National Institute of Standards and Technology for the USEPA (NIST 2004). However, more recent empirical studies have measured an average air exchange rate in commercial buildings from California of 1.6/hr, with a range of 0.3 to 9.1/hr (Bennett et al. 2012). Air exchange rates are typically higher in continually mechanically-ventilated office buildings than buildings that rely on a mixture of natural and mechanical ventilation (e.g., Jia et al. 2010).

Peer-reviewed, vapor intrusion guidance published by a San Francisco Bay office of the California Environmental Protection Agency selected a default IAER of 1.0/hour for residential structures, near the mid-range of IAERs noted in previous studies for California (CALEPA 2008; Kauffman 2003). The higher IAER relative to interior and southern California is based on the Mediterranean climate of that area, typified by cool summers that promote the use of natural ventilation and largely preclude the need for air conditioning. Windows of homes are often left cracked or open even when temperatures fall below 65°F in order to maintain ventilation, with heating consistently employed only when temperatures fall below 55°F. A default IAER of 2.0/hour is recommended for commercial facilities. A similar IAER is recommended in vapor intrusion guidance for the tropical climate of Hawai'i, due to a greater reliance on leakage and natural ventilation to meet cooling needs (HDOH 2011).

1.2 Minimum IAERs

Home ventilation standards require a minimum ventilation rate of 0.35 air changes per hour and no less than 15 cubic feet per minute (7.5 liters per second) per person (ASHRAE 2013b; see also LBNL 1998; USDOE 2002; MHRA 2003; USEPA 2010). This is supported by studies of minimal IAERs required to keep VOCs from indoor sources below risk-based guidelines for indoor air (e.g., Gilbert et al. 2008). With the caveats noted below, this represents a reasonable, lower threshold for development of vapor intrusion screening tools.

Sherman and Matson (2011) concluded that approximately 95% of current housing stock for the US as a whole meets the intent of this standard based on house leakage alone. House leakage and mechanical ventilation simulations for selected cities by Persily et al. (2010) suggest that the proportion of homes that meet a minimum ventilation of 0.35/hour could be lower in some areas, although this again does not take into account natural ventilation during moderate weather. Earlier tracer studies suggest that air exchange is generally met in the

warmest parts of the country, due to the more frequent use of open doors and windows, but may not be met in up to 25% of homes for colder areas of the country (Murray and Burmaster 1995). Lower IAERs are primarily associated with tight, newer homes when air conditioning is being used (Sherman and Matson 2011), but this is likely to be accompanied by a similarly reduced, intrusion rate of subsurface vapors due to a positive pressure in the lower portions of the home (see also McHugh et al. 2012 and Song et al. 2014). Impacts to indoor air quality by indoor and outdoor vapor sources are likely to outweigh risks posed by vapor intrusion under these conditions (see ASHRAE 2013a). Short-term IAERs can also vary significantly within a given day (Holton et al. 2013). A long-term, annual average IAER of less than 0.35/hour indicates inadequate ventilation and an improperly constructed home that should be corrected as part of the vapor intrusion investigation.

2.0 Vapor Intrusion and Building Leakage

An advective flow of subsurface vapors into a building and entry through cracks and gaps in the building floor can occur if the building becomes depressurized relative to the air beneath the slab (or in the crawl space). This flow is most commonly associated with heating, exhaust fans, and/or strong persistent winds (Johnson and Ettinger 1991; USEPA 2004; ITRC 2007; USEPA 2012). Other factors that can affect pressurization and lead to subslab vapor intrusion (or indoor air *extrusion*) include (after Patterson and Davis 2009): (1) short-term barometric pressure changes, (2) longer-term meteorologically induced barometric pressure changes (e.g., periodic storm events), (3) rainfall events, (4) thermal differences between indoors and outdoors, (5) imbalanced building ventilation, and (6) overall building tightness.

These factors can cause leakage of outdoor air into a structure. This well-studied phenomenon serves as a useful surrogate for understanding vapor intrusion into buildings. Differences in temperature and stack pressures between indoor and outdoor air can lead to a “stack effect” that drives airflow into or out of a building (Walker and Wilson 1998; ASHRAE 2009; ASHRAE 2013a; Song et al. 2014). When indoor air is warmer than outdoor air, the air rises and leaks out through the upper parts of the structure (“stack effect”). The base of the building becomes depressurized relative to ambient air and outdoor air leaks in through cracks and gaps in the structure. If gaps are present in the floor, subsurface vapors can leak into the building. Strong winds can cause the downwind side of a structure to become depressurized, allowing outward leakage of indoor air and similar inward leakage of outdoor air on the upwind side of the structure, as well as the upward intrusion of subsurface vapors through the floor. Leakage of mechanical ventilation duct systems to outdoor air can or pressurize (return leak) or depressurize (supply leak) a building.

Pressurization of a building due to air conditioning, humidity control or other factors can result in the *outward* leakage of air (ASHRAE 2009, 2013a; see also MHRA 2003; USEPA 2010, 2012; Song et al. 2014) and the potential *extrusion* of indoor air into the subslab area (McHugh et al. 2006, 2012). This can result in the outward leakage of indoor air in this area and the potential *extrusion* of indoor air into subslab soils (McHugh et al. 2006, 2012). Pressurization of lower floors can also occur in heated buildings. The ground level of tall buildings is often put under positive pressure to reduce in the inflow of cold air at entries (ASHRAE 2009). Pressurization of rooms with closed doors can occur in buildings that are heated by a central forced-air duct system and the rooms include a supply register but no return grille. The advective vapor entry rate during these periods would be negative or effectively zero from a vapor intrusion perspective. Positive pressurization of commercial buildings and apartment buildings with attached garages is also typically required by the

building permit in order to prevent the infiltration of exhaust (MHRA 2003; USEPA 2010). Wind, barometric pressure changes and other climatic factors can cause daily as well as seasonal pressurization (see McHugh et al. 2006, 2012; Song et al. 2014). Temporary depressurization of buildings normally under positive pressure can, however, be caused by exceptionally high winds or low ambient temperatures.

Open windows and doors can lead to more neutral pressure conditions and, in the absence of wind, reduce or eliminate the effect of subsurface vapor entry into buildings. Radon field studies have demonstrated that reducing building depressurization by opening windows can lower the advective entry of subsurface vapors by as much as a factor of five (Cavallo et al. 1992). These studies suggest that radon flow is a linear function of building depressurization up to a differential pressure of four Pascals or 40 g/cm-s^2 , the default differential used in the USEPA (2004) vapor intrusion models (see also Song et al. 2014). This was compounded by a doubling of the indoor air exchange rate, for a total ten-fold reduction in measured impacts to indoor air.

References

- American Society of Heating, Refrigerating and Air-Conditioning Engineers (ASHRAE). 2002. *Measuring Air Change Effectiveness*. Standard 129-1997 (RA 2002). Atlanta, GA.
- American Society of Heating, Refrigerating and Air-Conditioning Engineers (ASHRAE). 2006. *A Method of Determining Air Change Rates in Detached Dwellings*. Standard 136-1993 (RA 2006). Atlanta, GA.
- American Society of Heating, Refrigerating and Air-Conditioning Engineers (ASHRAE). 2009. *ASHRAE Handbook - Fundamentals*. Atlanta, GA.
- American Society of Heating, Refrigerating and Air-Conditioning Engineers (ASHRAE). 2013a. *Handbook of Fundamentals*. Atlanta, GA.
- American Society of Heating, Refrigerating and Air-Conditioning Engineers (ASHRAE). 2013b. *Ventilation for Acceptable Indoor Air Quality*. Standard 62.1. Atlanta, GA.
- American Society for Testing and Materials (ASTM). 1990. *Air Change Rate and Air Tightness in Buildings*. Edited by M. H. Sherman. STP:1067. Philadelphia, PA.
- American Society for Testing and Materials (ASTM). 2000. *Standard Test Method for Determining Air Change in a Single Zone by Means of a Tracer Gas Dilution*. ASTM E741-00. West Conshohocken, PA.
- Batterman, S., C. Jia, G. Hatzivasilis, and C. Godwin. 2006. Simultaneous measurement of ventilation using tracer gas techniques and VOC concentrations in homes, garages and vehicles. *Journal of Environmental Monitoring* 8: 249-256.
- Bennett, D. H., W. Fisk, M. G. Apte, X. Wu, A. Trout, D. Faulkner and D. Sullivan, 2012. Ventilation, temperature, and HVAC characteristics in small and medium commercial buildings in California. *Indoor Air* 22: 309–320.

- Breen, M., M. Bren, R.W. Williams and B.D. Schultz. 2010. Predicting residential air exchange rates from questionnaires and meteorology: Model evaluation in central North Carolina. *Environ. Sci. Technol.* 44: 9349–9356.
- California Energy Commission (CEC). 2001. *Manual for Compliance with the 2001 Energy Efficiency Standards (for Nonresidential Buildings, High-Rise Residential Buildings, and Hotels/Motels)*, Document No. P400-01-032.
- California Environmental Protection Agency (CalEPA), Regional Water Quality Control Board, San Francisco Bay Area Region. 2008. *Screening for Environmental Concerns at Sites with Contaminated Soil and Groundwater*. May 2008.
- California Environmental Protection Agency (CalEPA), Department of Toxic Substances Control. 2011. *Guidance for the Evaluation and Mitigation of Subsurface Vapor Intrusion to Indoor Air*. October 2011.
- Cavallo, A., K. Gadsby, T. A. Reddy, and R. Socolow. 1992. The effect of natural ventilation on radon and radon progeny levels in houses. *Radiation Protection Dosimetry* 45: 569–573.
- Chan, W.R., W.W. Nazaroff, P.N. Price, M.D. Sohn and A.J. Gadgil. 2005. Analyzing a database of residential air leakage in the United States. *Atmospheric Environment* 39: 3445–3455.
- Gilbert, N.L., M. Guaya, D. Gauvinb, R.N. Dietzc, C.C. Chand and B. Le´vesque. 2008. Air change rate and concentration of formaldehyde in residential indoor air. *Atmospheric Environment* 42: 2424–2428.
- Hawaii Department of Health (HDOH), Office of Hazard Evaluation and Emergency Response. 2011. *Evaluation of Environmental Hazards at Sites with Contaminated Soil and Groundwater*. Fall 2011.
- Hers, I., R. Zapf-Gilje, L. Li, and J. Atwater. 2001. The use of indoor air measurements to evaluate intrusion of subsurface VOC vapors into buildings. *J. Air & Waste Manage. Assoc.* 51: 1318–1331.
- Holton, C., H. Luo, P. Dahlen, K. Gorder, E. Dettenmaier and P.C. Johnson. 2013. Temporal variability of indoor air concentrations under natural conditions in a house overlying a dilute chlorinated solvent groundwater plume. *Environmental Science and Technology* 47: 13347-13354.
- Interstate Technology & Regulatory Council (ITRC). 2007. *Vapor Intrusion Pathway: A Practical Guideline*. Washington, DC.
- Jia, C., S. Batterman, C. Godwin, S. Charles and J.Y. Chin. 2012. Sources and migration of volatile organic compounds in mixed-use buildings. *Indoor Air* 20: 357–369.
- Johnson, P.C., and R.A. Ettinger. 1991. Heuristic model for predicting the intrusion rate of contaminant vapors into buildings. *Environmental Science Technology* 25: 1445–1452.

- Johnson, P.C., 2002. Identification of Critical Parameters for the Johnson and Ettinger (1991) Vapour Intrusion Model. American Petroleum Institute Technical Bulletin #17.
- Johnson, P.C., 2005. Identification of Application-Specific Critical Inputs for the 1991 Johnson and Ettinger Vapor Intrusion Algorithm. *Groundwater Monitoring & Remediation* 25, no. 1: 63–78.
- Kauffman, E. 2003. “Climate and Topography,” in *Atlas of the Biodiversity of California*, ed. M. Parisi (Sacramento: California Department of Fish and Wildlife, 2003), 12-15.
- Koontz, M.D. and H.E. Rector. 1995. *Estimation of distributions for residential air exchange rates*. U.S. Environmental Protection Agency. Office of Pollution Prevention and Toxics, Washington, DC.
- Lawrence Berkeley National Laboratory (LBNL). 1998. *Recommended Ventilation Strategies for Energy-Efficient Production Homes*. Berkeley, CA: Lawrence Berkeley National Laboratory, Energy Analysis Department, Environmental Energy Technologies Division.
- Manufactured Housing Research Alliance (MHRA). 2003. *Whole House Ventilation Strategies*. New York, NY.
- Marr, D., M. Mason, R. Mosley and X.Y. Liu. 2012. The influence of opening windows and doors on the natural ventilation rate of a residential building. *HVAC&R Research* 18, no. 1–2: 195–203.
- McHugh, T.E., P.C. De Blanc, and R.J. Pokluda. 2006. Indoor air as a source of VOC contamination in shallow soils below buildings. *Soil & Sediment Contamination* 15: 103–122.
- McHugh, T.E., L. Beckley, D. Bailey, K. Gorder, E. Dettenmaier, I. Rivera-Duarte, S. Brock and I.C. MacGregor. 2012. Evaluation of vapor intrusion using controlled building pressure. *Environmental Science and Technology* 46: 4792–4799.
- Murray, D.M. and D.E. Burmaster. 1995. Residential air exchange rates in the United States: empirical and estimated parametric distribution by season and climatic region. *Risk Analysis* 15, no. 4: 459–465.
- Nazaroff, W.W., S.M. Doyle, A.V. Nero, and R.G. Sextro. 1988. Radon entry via potable water. In *Radon and its Decay Products in Indoor Air*, ed. Nazaroff, W.W. and A.V. Nero, 131-157. New York: Wiley-Interscience.
- National Institute of Standards and Technology (NIST). 2004. *Analysis of Ventilation Data from the U.S. Environmental Protection Agency Building Assessment Survey and Evaluation (BASE) Study*. NISTIR 7145. Gaithersburg, MD.
- Pandian, M.D., J.V. Behar, W.R. Ott, L.A. Wallace, A.L. Wilson, S.D. Colome and M. Koontz. 1998. Correcting errors in the nationwide data base of residential air exchange rates. *Journal of Exposure Analysis and Environmental Epidemiology* 8, no.4: 577–586.

- Patterson, B., and G. Davis. 2009. Quantification of vapor intrusion pathways into a slab-on-ground building under varying environmental conditions. *Environmental Science and Technology* 43: 650–656.
- Persily, A., A. Musser and S.J. Emmerich. 2010. Modeled infiltration rate distributions for U.S. housing. *Indoor Air* 20: 473–485.
- Sherman, M. and N. Matson. 2011. *Residential Ventilation and Energy Characteristics*. Lawrence Berkeley National Laboratory, Energy Performance of Buildings Group, Energy and Environment Division, Berkeley, CA.
- Song, S., B.A. Schnorr and F.C. Ramacciotti. 2014. Quantifying the Influence of Stack and Wind Effects on Vapor Intrusion. *Human and Ecological Risk Assessment* (in press).
- U.S. Department of Energy (USDOE), Building Technologies Program, Office of Energy Efficiency and Renewable Energy. 2002. *Spot Ventilation - Source control to improve indoor air quality (Technology Fact Sheet)*. Washington, DC.
- U.S. Energy Information Administration (USEIA). 2003. *Commercial Buildings Energy Consumption Survey Climate Zones*. Washington, DC.
- U.S. Environmental Protection Agency (USEPA), Office of Emergency and Remedial Response. 2004. *User's Guide for Subsurface Vapor Intrusion into Buildings*. Washington, DC.
- U.S. Environmental Protection Agency (USEPA), Office of Radiation and Indoor Air, Indoor Environments Division. 2010. *Building Codes and Indoor Air Quality*. Washington, DC.
- U.S. Environmental Protection Agency (USEPA), Office of Research and Development, National Center for Environmental Assessment. 2011. *Exposure Factors Handbook*. EPA/600/R-090/052F. Washington, DC.
- U.S. Environmental Protection Agency (USEPA), Office of Solid Waste and Emergency Response. 2012. *Conceptual Model Scenarios for the Vapor Intrusion Pathway*. EPA 530-R-10-003. Washington, DC.
- Wallace, L.A., S.J. Emmerich and C. Howard-Reed. 2002. Continuous measurements of air change rates in an occupied house for 1 year: The effect of temperature, wind, fans and windows. *Journal of Exposure Analysis and Environmental Epidemiology* 12: 296-306.
- Walker, I.S., and D.J. Wilson. 1998. Field validation of algebraic equations for stack and wind driven air infiltration calculations. *HVAC&R Research Journal* 4, no. 2: 119–139.
- Wilson, A.L., S.D. Colome, Y. Tian, E.W. Beck, P.E. Baker, D.W. Behrens, I.H. Billick and C.A. Garrison. 1996. California residential air exchange rates and residence volumes. *Journal of Exposure Analysis and Environmental Epidemiology* 6, no. 3:311–326.

Yamamoto, N., D.G. Shendell, A.M. Winter and J. Zhang, 2010, Residential air exchange rates in three U.S. metropolitan areas: results from the relationship among indoor, outdoor, and personal air study 1999-2001. *Indoor Air* 20: 85–90.

**USER'S GUIDE FOR
EVALUATING SUBSURFACE VAPOR INTRUSION
INTO BUILDINGS**

Prepared By

Environmental Quality Management, Inc.
Cedar Terrace Office Park, Suite 250
3325 Durham-Chapel Hill Boulevard
Durham, North Carolina 27707-2646

Prepared For

Industrial Economics Incorporated
2667 Massachusetts Avenue
Cambridge, Massachusetts 02140

EPA Contract Number: 68-W-02-33
Work Assignment No. 004
PN 030224.0002

For Submittal to

Janine Dinan, Work Assignment Manager

U.S. ENVIRONMENTAL PROTECTION AGENCY
OFFICE OF EMERGENCY AND REMEDIAL RESPONSE
ARIEL RIOS BUILDING, 5202G
1200 PENNSYLVANIA AVENUE, NW
WASHINGTON, D.C. 20460

Revised February 22, 2004

DISCLAIMER

This document presents technical and policy recommendations based on current understanding of the phenomenon of subsurface vapor intrusion. This guidance does not impose any requirements or obligations on the U.S. Environmental Protection Agency (EPA) or on the owner/operators of sites that may be contaminated with volatile and toxic compounds. The sources of authority and requirements for addressing subsurface vapor intrusion are the applicable and relevant statutes and regulations. This guidance addresses the assumptions and limitations that need to be considered in the evaluation of the vapor intrusion pathway. This guidance provides instructions on the use of the vapor transport model that originally was developed by P. Johnson and R. Ettinger in 1991 and subsequently modified by EPA in 1998, 2001, and again in November 2002. On November 29, 2002 EPA published Draft Guidance for Evaluating the Vapor Intrusion to Indoor Air Pathway from Groundwater and Soils (Federal Register: November 29, 2002 Volume 67, Number 230 Page 71169-71172). This document is intended to be a companion for that guidance. Users of this guidance are reminded that the science and policies concerning vapor intrusion are complex and evolving.

CONTENTS

Figures	v
Tables	vi
Acknowledgment	vii
What's New in this Version	viii
1. Introduction to the Vapor Intrusion Model Theory and Application	1
2. Model Theory	3
2.1 Model Setting	3
2.2 Vapor Concentration at the Source of Contamination	6
2.3 Diffusion Through the Capillary Zone	14
2.4 Diffusion Through the Unsaturated Zone	19
2.5 The Infinite Source Solution to Convective and Diffusive Transport	20
2.6 The Finite Source Solution to Convective and Diffusive Transport	24
2.7 The Soil Gas Models	26
2.8 Soil Vapor Permeability	26
2.9 Calculation of a Risk-Based Soil or Groundwater Concentration	28
2.10 Calculation of Incremental Risks	30
2.11 Major Model Assumptions/Limitations	30
3. Soil and Groundwater Model Application	33
3.1 Justification of Default Soil-Dependent Properties	37
3.2 Justification of Default Building-Related Properties	38
3.3 Running the Models	41
3.4 The Data Entry Sheet (DATENTER)	42
3.5 The Results Sheet (RESULTS)	57
3.6 The Chemical Properties Sheet (CHEMPROPS)	58
3.7 The Intermediate Calculations Sheet (INTERCALCS)	58
3.8 The Lookup Tables (VLOOKUP)	58
3.9 Adding, Deleting, or Revising Chemicals	58

CONTENTS (continued)

4.	Soil Gas Model Application	60
4.1	Running the Models	60
4.2	Soil Gas Sampling	61
4.3	Assumptions and Limitations of the Soil Gas Models	65
5.	Assumptions and Limitations of the J&E Model	67
5.1	Source Vapor Concentration	73
5.2	Soil Vapor Permeability	74
5.3	Rise of and Diffusion Across the Capillary Zone	74
5.4	Diffusive and Convective Transport into the Structure	75
6.	Interpretation of Results	77
Appendices		
A.	User's Guide for Non-Aqueous Phase Liquids	A-1
B.	Chemical Properties Lookup Table and References	B-1
C.	Example Worksheets for the Advanced Soil Contamination Model	C-1
D.	Sample Data Entry Sheets for Each Model	D-1
E.	Bibliography and Reference List	E-1

FIGURES

<u>Number</u>		<u>Page</u>
1	Pathway for Subsurface Vapor Intrusion into Indoor Air	4
2	Vapor Pathway into Buildings	5
3	U.S. Soil Conservation Service Classification Chart Showing Centroid Compositions (Solid Circles)	18
4	GW-SCREEN Data Entry Sheet	43
5	GW-ADV Data Entry Sheet	44
6	Example Error Message on Data Entry Sheet	46
7	Example Error Message on Results Sheet	46
8	Average Shallow Groundwater Temperature in the United States	48
9	Floor Slab and Foundation	55
10	SG-ADV Data Entry Sheet	62

TABLES

<u>Number</u>		<u>Page</u>
1	Screening List of Chemicals	7
2	Values of Exponent n as a Function of T_B/T_C	13
3	Class Average Values of the Van Genuchten Soil Water Retention Parameters for the 12 SCS Soil Textural Classifications	16
4	Centroid Compositions, Mean Particle Diameters and Dry Bulk Density of the 12 SCS Soil Textural Classifications	19
5	Class Average Values of Saturated Hydraulic Conductivity for the 12 SCS Soil Textural Classifications	27
6	Uncertainty and Sensitivity of Key Parameters for the Vapor Intrusion Model	32
7	Range of Values for Selected Model Input Parameters	34
8	Effect on Building Concentration from an Increase in Input Parameter Values	35
9	Building-Related Parameters for the Vapor Intrusion Model	36
10	Soil-Dependent Properties for the Vapor Intrusion Model First Tier Assessment	37
11	Guidance for Selection of Soil Type	37
12	Assumptions and Limitations of the Vapor Intrusion Model	68

ACKNOWLEDGMENT

Environmental Quality Management, Inc. (EQ) via Industrial Economics Incorporated (IEC) Subcontract No. 3073-002 prepared this document and the accompanying spreadsheets for the U.S. Environmental Protection Agency (EPA). Mr. Tom Robertson (EQ Project Manager) and Mr. Henry Roman (IEC Project Manager) managed the project. The work was completed on behalf of the U.S. EPA Office of Solid Waste. Ms. Janine Dinan was the government's Project Manager.

EPA	Helen Dawson Janine Dinan Jayne Michauo Debbie Newberry David Riley Henry Schuver
IEC	Adena Greenbaum Henry Roman Eric Ruder
EQ	Dave Dunbar Josh Dunbar Tena Pipkin Tom Robertson
Golder Associates	Mr. Ian Hers

WHAT'S NEW IN THIS VERSION!

This revised version of the User's Guide corresponds with the release of Version 3.1 of the Johnson and Ettinger (1991) model (J&E) spreadsheets for estimating subsurface vapor intrusion into buildings. Several things have changed within the models since Version 2 was released in December 2000 and since the original version was released in September 1998. The following represent the major changes in Version 3.1 to be consistent with Draft Guidance for Evaluating the Vapor Intrusion to Indoor Air Quality from Groundwater and Soils dated November 25, 2002 as referenced below:

1. Table 1 lists the chemicals that are commonly found at contaminated sites. This list has been expanded from the list of chemicals included in Version 2 of the model. We have also applied certain criteria to determine whether it is appropriate to run the model for these contaminants. Only those contaminants for which all of the toxicological or physical chemical properties needed to make an assessment of the indoor inhalation risk are included in the spreadsheets. A chemical is considered to be sufficiently toxic if the vapor concentration of the pure component poses an incremental life time cancer risk greater than 1×10^{-6} or the noncancer hazard index is greater than 1. A chemical is considered to be sufficiently volatile if its Henry's law constant is 1×10^{-5} atm-m³/mole or greater. The final chemical list for Version 3 includes 108 chemicals.
2. **Chemical Property Data** - The source of chemical data used in the calculation is primarily EPA's Superfund Chemical Data Matrix (SCDM) database. EPA's WATER9 database is used for chemicals not included in the SCDM database. Appendix B contains other data sources. Henry's Law value for cumene is incorrect in the above listed reference. The correct value was determined by using EPA's system performs automated reasoning in chemistry algorithms found in "Prediction of Chemical Reactivity Parameters and Physical Properties of Organic Compounds from Molecular Structure Using SPARE." EPA-2003.
3. **Toxicity Values** – EPA's Integrated Risk Information System (IRIS) is the generally preferred source of carcinogenic unit risks and non-carcinogenic reference concentrations (RfCs) for inhalation exposure.¹ The following two sources were consulted, in order of preference, when IRIS values were not available: provisional toxicity values recommended by EPA's National Center for Environmental Assessment (NCEA) and EPA's Health Effects Assessment Summary Tables (HEAST). If no inhalation toxicity data could be obtained from IRIS, NCEA, or HEAST, extrapolated unit risks and/or RfCs using toxicity data for oral exposure (cancer slope factors and/or reference doses, respectively) from these same sources

¹ U.S. EPA. 2002. Integrated Risk Information System (IRIS). <http://www.epa.gov/iriswebp/iris/index.html>. November.

using the same preference order were used.² Note that for most compounds, extrapolation from oral data introduces considerable uncertainty into the resulting inhalation value. Values obtained from inhalation studies or from pharmacokinetic modeling applied to oral doses will be less uncertain than those calculated using the equations noted in footnote 2.

IRIS currently does not include carcinogenicity data for trichloroethylene (TCE), a volatile contaminant frequently encountered at hazardous waste sites. The original carcinogenicity assessment for TCE, which was based on a health risk assessment conducted in the late 1980's, was withdrawn from IRIS in 1994. The Superfund Technical Support Center has continued to recommend use of the cancer slope factor from the withdrawn assessment, until a reassessment of the carcinogenicity of TCE is completed. In 2001, the Agency published a draft of the TCE toxicity assessment for public comment.³ Using this guidance, TCE target concentrations for the draft vapor intrusion guidance were calculated using a cancer slope factor identified in that document, which is available on the NCEA web site. This slope factor was selected because it is based on state-of-the-art methodology. However, because this document is still undergoing review, the slope factor and the target concentrations calculated for TCE are subject to change and should be considered "provisional" values.

Toxicity databases such as IRIS are routinely updated as new information becomes available; the data included in the lookup tables are current as of December 2003. Users of these models are strongly encouraged to research the latest toxicity values for contaminants of interest from the sources noted above. In the next year, IRIS reassessments are expected for several contaminants commonly found in subsurface contamination whose inhalation toxicity values are currently based on extrapolation.

4. Assumption and Limitations

The Johnson and Ettinger (J&E) Model was developed for use as a screening level model and, consequently, is based on a number of simplifying assumptions regarding contaminant distribution and occurrence, subsurface characteristics, transport mechanisms, and building construction. The assumptions of the J&E Model as implemented in EPA's spreadsheet version are listed in Section 2.11, Section 5, and

² The oral-to-inhalation extrapolations assume an adult inhalation rate (IR) of 20 m³/day and an adult body weight (BW) of 70 kg. Unit risks (URs) were extrapolated from cancer slope factors (CSFs) using the following equation:

$$UR (\mu\text{g}/\text{m}^3)^{-1} = \text{CSF} (\text{mg}/\text{kg}/\text{d})^{-1} * \text{IR} (\text{m}^3/\text{d}) * (1/\text{BW})(\text{kg}^{-1}) * (10^{-3} \text{ mg}/\mu\text{g})$$

Reference concentrations (RfCs) were extrapolated from reference doses (RfDs) using the following equation:

$$\text{RfC} (\text{mg}/\text{m}^3) = \text{RfD} (\text{mg}/\text{kg}/\text{d}) * (1/\text{IR}) (\text{m}^3/\text{d})^{-1} (\text{BW} (\text{kg}))$$

³ US EPA, Trichloroethylene Health Risk Assessment: Synthesis and Characterization – External Review Draft, Office of Research and Development, EPA/600/P-01-002A, August, 2001.

Table 12 along with an assessment of the likelihood that the assumptions can be verified through field evaluation.

5. Soil Parameters

A list of generally reasonable, yet conservative, model input parameters for selected soil and sampling related parameters are provided in Tables 7 and 8. These tables also provide the practical range, typical or mean value (if applicable), and most conservative value for these parameters. For building parameters with low uncertainty and sensitivity, only a single “fixed” value corresponding to the mean or typical value is provided in Table 9. Soil-dependent properties are provided in Table 10 for soils classified according to the US Soil Conservation Soil (SCS) system. If site soils are not classified according to the US SCS, Table 11 can be used to assist in selecting an appropriate SCS soil type corresponding to the available site lithologic information. Note that the selection of the soil texture class should be biased towards the coarsest soil type of significance, as determined by the site characterization program. These input parameters were developed considering soil-physics science, available studies of building characteristics, and expert opinion. Consequently, the input parameters listed in Tables 7 and 8 are considered default parameters for a first-tier assessment, which should in most cases provide a reasonably (but not overly) conservative estimate of the vapor intrusion attenuation factor for a site. The soil water filled porosity (θ_w) is dependent on the soil type and the default value was removed from the model set up. Users must define soil type or input a value for the porosity.

6. Building Parameters

Building Air Exchange Rate (Default Value = 0.25 hr⁻¹)

Results from 22 studies for which building air exchange data are available were summarized in Hers et al. (2001). When all the data were analyzed, the 10th, 50th, and 90th percentile values were 0.21, 0.51, and 1.48 air exchanges per hour (AEH). Air exchange rates varied depending on season and climatic region. For example, for the winter season and coldest climatic area (Region 1, Great Lakes area and extreme northeast US), the 10th, 50th, and 90th percentile values were 0.11, 0.27, and 0.71 AEH. In contrast, for the winter season and warmest climatic area [Region 4 (southern California, Texas, Florida, Georgia)], the 10th, 50th, and 90th percentile values were 0.24, 0.48, and 1.13 AEH. For this guidance, a default value of 0.25 for air exchange rate was selected to represent the lower end of these distributions. The previous version of the guidance included a default value of 0.45 exchanges per hour.

Building Area and Subsurface Foundation Area (Default Value = 10 m by 10 m)

A Michigan study indicates that a 111.5 m² area approximately corresponds to the 10th percentile floor space area for residential single family dwellings, based on statistics compiled by the U.S. Department of Commerce (DOC) and U.S. Housing and Urban Development (HUD). The previous median value was 9.61 m x 9.61 m.

Building Mixing Height (Default Value = 2.44 m for slab-on-grade scenario; = 3.66 m for basement scenario)

The J&E Model assumes that subsurface volatiles migrating into the building are completely mixed within the building volume, which is determined by the building area and mixing height. The building mixing height will depend on a number of factors including the building height, the heating, ventilation and air conditioning (HVAC) system operation, environmental factors such as indoor-outdoor pressure differentials and wind loading, and seasonal factors. For a single-story house, the variation in mixing height can be approximated by the room height. For a multi-story house or apartment building, the mixing height will be greatest for houses with HVAC systems that result in significant air circulation (e.g., forced-air heating systems). Mixing heights will be less for houses using electrical baseboard heaters. It is likely that mixing height is, to some degree, correlated to the building air exchange rate.

There are little data available that provide for direct inference of mixing height. There are few sites, with a small number of houses where indoor air concentrations were above background, and where both measurements at ground level and the second floor were made (CDOT, Redfields, Eau Claire). Persons familiar with the data sets for these sites indicate that in most cases a fairly significant reduction in concentrations (factor of two or greater) was observed, although at one site (Eau Claire, "S" residence), the indoor TCE concentrations were similar in both the basement and second floor of the house. For the CDOT site apartments, there was an approximate five-fold reduction between the concentrations measured for the first floor and second floor units. Less mixing would be expected for an apartment because there are less cross-floor connections than for a house. The default value chosen for a basement house scenario (3.66 m) would be representative of a two-fold reduction or attenuation in vapor concentrations between floors.

Crack Width (0.1 cm) and Crack Ratio (Default Value = 0.0002 for basement house; = 0.0038 for slab-on-grade house)

The crack width and crack ratio are related. Assuming a square house and that the only crack is a continuous edge crack between the foundation slab and wall ("perimeter crack"), the crack ratio and crack width are related as follows:

$$\text{Crack Ratio} = \frac{4(\text{Crack Width} / \sqrt{\text{Subsurface Foundation Area}})}{\text{Subsurface Foundation Area}}$$

There is little information available on crack width or crack ratio. One approach used by radon researchers is to back calculate crack ratios using a model for soil gas flow through cracks and the results of measured soil gas flow rates into a building. For example, the back-calculated values for a slab/wall edge crack based on soil gas-entry rates reported in Nazaroff (1992), Revzan et al. (1991), and Nazaroff et al. (1985) range from approximately 0.0001 to 0.001. Another possible approach is to measure crack openings although this, in practice, is difficult to do. Figley and Snodgrass (1992) present data from ten houses where edge crack measurements were made. At the eight houses where cracks were observed, the cracks' widths ranged from hairline cracks up to 5 mm wide, while the total crack length per house ranged from 2.5 m to 17.3 m. Most crack widths were less than 1 mm. The suggested defaults for crack ratio is regulatory guidance, literature and models also vary. In ASTM E1739-95, a default crack ratio of 0.01 is used. The crack ratios suggested in the VOLASOIL model (developed by the Dutch Ministry of Environment) range from 0.0001 to 0.0000001. The VOLASOIL model values correspond to values for a "good" and "bad" foundation, respectively. The crack ratio used by J&E (1991) for illustrative purposes ranged from 0.001 to 0.01. The selected default values fall within the ranges observed.

Q_{soil} (Default Value = 5 L/min)

The method used to estimate the vapor flowrate into a building (Q_{soil}) is an analytical solution for two-dimensional soil gas flow to a small horizontal drain (Nazaroff 1992) ("Perimeter Crack Model"). Use of this model can be problematic in that Q_{soil} values are sensitive to soil-air permeability and consequently a wide range in flows can be predicted.

An alternate empirical approach was selected to determine the Q_{soil} value. This new approach is based on trace tests (i.e., mass balance approach). When soil gas advection is the primary mechanism for tracer intrusion into a building, the Q_{soil} value is estimated by measuring the concentrations of a chemical tracer in indoor air, outdoor air, and in soil vapor below a building, and measuring the building ventilation rate (Hers et al. 2000a; Fischer et al. 1996; Garbesi et al. 1993; Rezvan et al. 1991; Barbesi and Sectro 1989). The Q_{soil} values measured using this technique were compared to predicted rates using the Perimeter Crack model, for sites with coarse-grained soils. The Perimeter Crack model predictions are both higher and lower than the measured values, but overall are within one order of magnitude of the measured values. Although the Q_{soil} predicted by the models and measured using field tracer tests are uncertain, the results suggest that a "typical" range for houses on coarse-grained soils is on the order of 1 to 10 L/min. A disadvantage with the tracer

test approach is that there are only limited data, and there do not appear to be any tracer studies for field sites with fine-grained soils.

Because the advective flow zone is relatively limited in extent, the soil type adjacent to the building foundation is of importance. In many cases, coarse-grained imported fill is placed below foundations, and either coarse-grained fill, or disturbed, loose fill is placed adjacent to the foundation walls. Therefore, a conservative approach for the purposes of this guidance is to assume that soil gas flow will be controlled by coarse-grained soil, and not to rely on the possible reduction in flow that would be caused by fine-grained soils near the house foundation. For these reasons, a soil gas flow rate of 5 L/min (midpoint between 1 and 10 L/min) was chosen as the input value.

7. Convenience Changes

- Default values for soil bulk densities have been added to the lookup tables for the various soil types.
- Default values for soil water-filled porosity have been updated within the lookup tables for soil properties for the various soil types.
- The chemical data list has been expanded to include 108 chemicals. Chemical physical properties were reviewed and updated where applicable to provide the user with more accurate values.
- All of the lookup functions within the models were modified to include an exact match parameter, rather than a closest match. The models would previously return data for CAS Numbers not in the lookup tables. Although the DATENTER sheet informed the user that this CAS Number was not found, it would return values on the CHEMPROPS sheet that was the closest match. This caused some confusion and therefore was changed.
- CAS number and soil type pick lists were added to the cells within the models where the user is required to provide data in a specific format. The pick lists were added to assist the user from entering data that are not an acceptable parameter.
- All models were modified to require the user to specify the soil type of each stratum. In addition, a button was added that allows the user to automatically retrieve the default values for the soil type selected. These additions were added as a convenience to the user and soil selection can be ignored should site-specific data be available.
- All models were modified to include an input for the average vapor flow rate into the building (Q_{soil}) in liters/minute (L/min). This value can be left blank and the model will calculate the value of Q_{soil} as was done in previous versions.

- All models were also modified to include a button that will reset the default value on the DATENTER sheet. This button will allow the user to clear all values and reset the default values or reset only those values that have a default value. The user is also allowed to specify whether the values should be reset for the basement or slab-on-grade scenario.

SECTION 1

INTRODUCTION TO THE VAPOR INTRUSION MODEL THEORY AND APPLICATION

Volatilization of contaminants located in subsurface soils or in groundwater, and the subsequent mass transport of these vapors into indoor spaces constitutes a potential inhalation exposure pathway, which may need to be evaluated when preparing risk assessments. Likewise, this potential indoor inhalation exposure pathway may need evaluation when estimating a risk-based soil or groundwater concentration below which associated adverse health effects are unlikely.

Johnson and Ettinger (J&E) (1991) introduced a screening-level model that incorporates both convective and diffusive mechanisms for estimating the transport of contaminant vapors emanating from either subsurface soils or groundwater into indoor spaces located directly above the source of contamination. In their article, J&E reported that the results of the model were in qualitative agreement with published experimental case histories and in good qualitative and quantitative agreement with detailed three-dimensional numerical modeling of radon transport into houses.

The J&E Model is a one-dimensional analytical solution to convective and diffusive vapor transport into indoor spaces and provides an estimated attenuation coefficient that relates the vapor concentration in the indoor space to the vapor concentration at the source of contamination. The model is constructed as both a steady-state solution to vapor transport (infinite or non-diminishing source) and as a quasi-steady-state solution (finite or diminishing source). Inputs to the model include chemical properties of the contaminant, saturated and unsaturated zone soil properties, and structural properties of the building.

This manual provides documentation and instructions for using the vapor intrusion model as provided in the accompanying spreadsheets.

Model results (both screening and advanced) are provided as either a risk-based soil or groundwater concentration, or as an estimate of the actual incremental risks associated with a user-defined initial concentration. That is to say that the model will reverse-calculate an “acceptable” soil or groundwater concentration given a user-defined risk level (i.e., target risk level or target hazard quotient), or the model may be used to forward-calculate an incremental cancer risk or hazard quotient based on an initial soil or groundwater concentration.

The infinite source models for soil contamination and groundwater contamination should be used as first-tier screening tools. In these models, all but the most sensitive model parameters have

been set equal to central tendency or upper bound values. Values for the most sensitive parameters may be user-defined.

More rigorous estimates may be obtained using site-specific data and the finite source model for soil contamination. Because the source of groundwater contamination may be located upgradient of the enclosed structure for which the indoor inhalation pathway is to be assessed, the advanced model for contaminated groundwater is based on an infinite source of contamination, however, site-specific values for all other model parameters may be user-defined.

In addition to the finite and infinite source models referred to above, two models that allow the user to input empirical soil gas concentration and sampling depth information directly into the spreadsheets. These models will subsequently estimate the resulting steady-state indoor air concentrations and associated health risks.

Because of the paucity of empirical data available for either bench-scale or field-scale verification of the accuracy of these models, as well as for other vapor intrusion models, the user is advised to consider the variation in input parameters and to explore and quantify the impacts of assumptions on the uncertainty of model results. At a minimum, a range of results should be generated based on variation of the most sensitive model parameters.

SECTION 2

MODEL THEORY

Chemical fate and transport within soils and between the soil column and enclosed spaces are determined by a number of physical and chemical processes. This section presents the theoretical framework on which the J&E Model is based, taking into account the most significant of these processes. In addition, this section also presents the theoretical basis for estimating values for some of the most sensitive model parameters when empirical field data are lacking. The fundamental theoretical development of this model was performed by J&E (1991).

2.1 MODEL SETTING

Consider a contaminant vapor source (C_{source}) located some distance (L_T) below the floor of an enclosed building constructed with a basement or constructed slab-on-grade. The source of contamination is either a soil-incorporated volatile contaminant or a volatile contaminant in solution with groundwater below the top of the water table.

Figure 1 is a simplified conceptual diagram of the scenario where the source of contamination is incorporated in soil and buried some distance below the enclosed space floor. At the top boundary of contamination, molecular diffusion moves the volatilized contaminant toward the soil surface until it reaches the zone of influence of the building. Here convective air movement within the soil column transports the vapors through cracks between the foundation and the basement slab floor. This convective sweep effect is induced by a negative pressure within the structure caused by a combination of wind effects and stack effects due to building heating and mechanical ventilation.

Figure 2 illustrates the scenario where the source of contamination is below the top of the water table. Here the contaminant must diffuse through a capillary zone immediately above the water table and through the subsequent unsaturated or vadose zone before convection transports the vapors into the structure.

The suggested minimum site characterization information for a first-tier evaluation of the vapor intrusion pathway includes: site conceptual model, nature and extent of contamination distribution, soil lithologic descriptions, groundwater concentrations, and/or possibly near source soil vapor concentrations. The number of samples and measurements needed to establish this information varies by site, and it is not possible to provide a hard and fast rule.

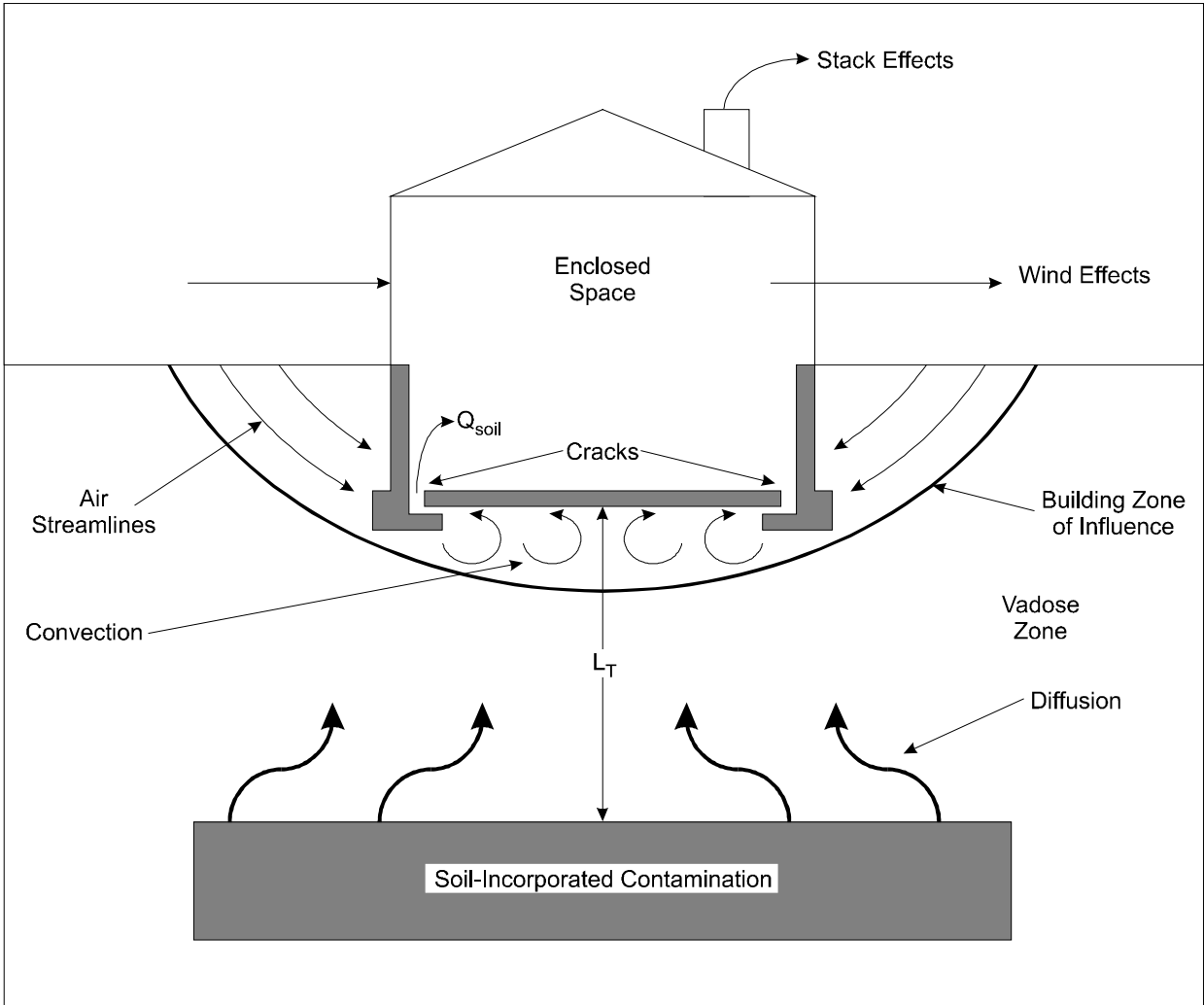

Figure 1. Pathway for Subsurface Vapor Intrusion into Indoor Air

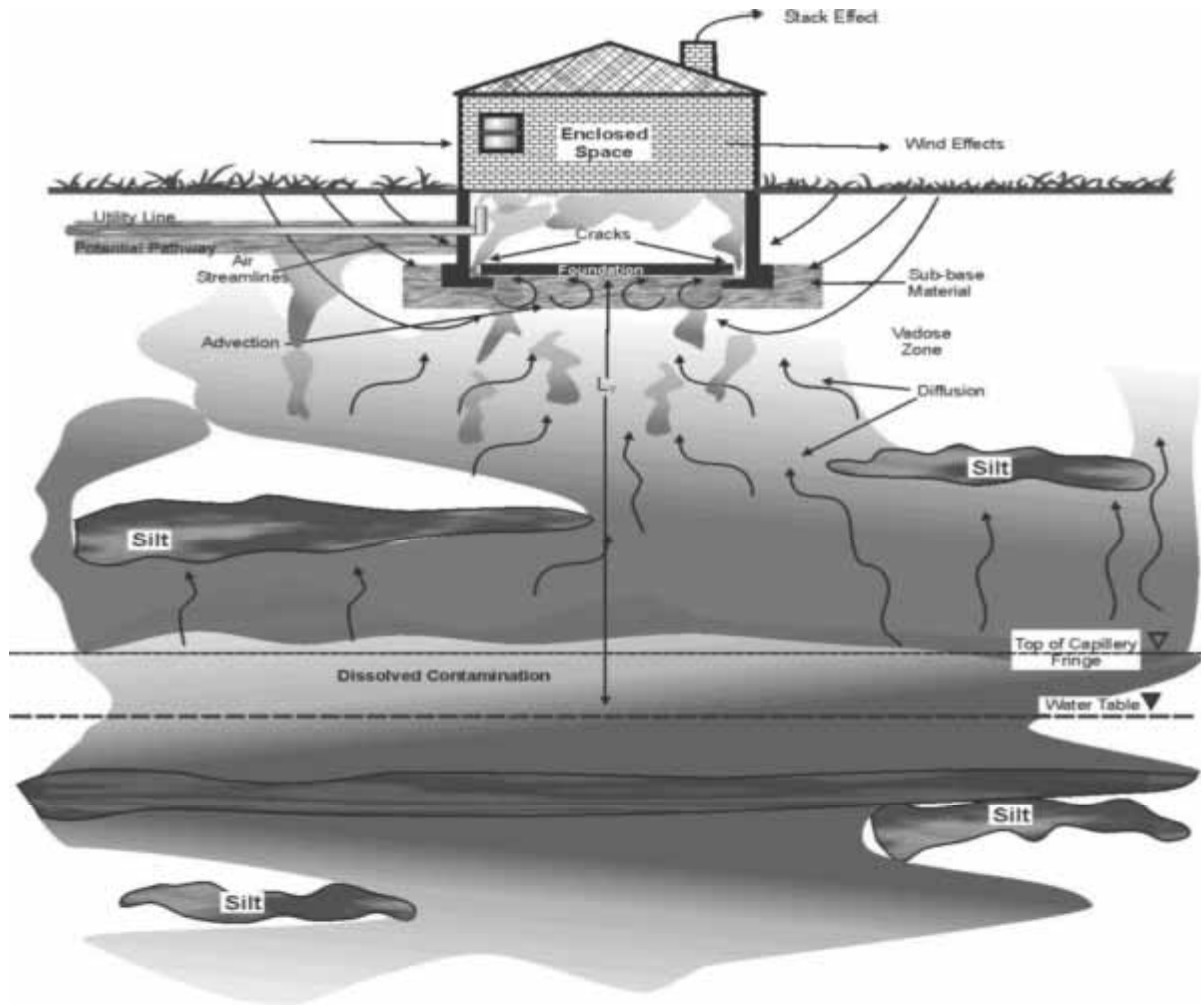

Figure 2. Vapor Pathway into Buildings

Based on the conceptual site model, the user can select the appropriate spreadsheet corresponding to the vapor source at the site and determine whether to use the screening level spreadsheet (which accommodates only one soil type above the capillary fringe) or the more advanced version (which allows up to three layers above the capillary fringe). As most of the inputs to the J&E Model are not collected during a typical site characterization, conservative inputs are typically estimated or inferred from available data and other non-site specific sources of information.

Table 1 lists 114 chemicals that may be found at hazardous waste sites and it indicates whether the chemical is sufficiently toxic and volatile to result in a potentially unacceptable indoor inhalation risk. It also provides a column for checking off the chemicals found or reasonably suspected to be present in the subsurface at a site. Under this approach, a chemical is considered sufficiently toxic if the vapor concentration of the pure component poses an incremental lifetime cancer risk greater than 10^{-6} or results in a non-cancer hazard index greater than one. A chemical is considered sufficiently volatile if its Henry's Law Constant is 1×10^{-5} atm-m³/mol or greater (EPA, 1991). It is assumed that if a chemical does not meet both of these criteria, it need not be further considered as part of the evaluation. Table 1 also identifies six chemicals that meet the toxicity and volatility criteria but are not included in the vapor intrusion models because one or more of the needed physical or chemical properties has not been found in the literature.

The rate of soil gas entry (Q_{soil}) or average vapor flow rate into the building is a function solely of convection; however, the vapor concentration entering the structure may be limited by either convection or diffusion depending upon the magnitude of the source-building separation (L_T).

2.2 VAPOR CONCENTRATION AT THE SOURCE OF CONTAMINATION

With a general concept of the problem under consideration, the solution begins with an estimate of the vapor concentration at the source of contamination.

In the case of soil contamination, the initial concentration (C_R) does not contain a residual-phase (e.g., nonaqueous-phase liquid or solid); and in the case of contaminated groundwater, the initial contaminant concentration (C_W) is less than the aqueous solubility limit (i.e., in solution with water).

Given these initial conditions, C_{source} for soil contamination may be estimated from Johnson et al. (1990) as:

$$C_{source} = \frac{H'_{TS} C_R \rho_b}{\theta_w + K_d \rho_b + H'_{TS} \theta_a} \quad (1)$$

where C_{source} = Vapor concentration at the source of contamination, g/cm³-v

H'_{TS} = Henry's law constant at the system (soil) temperature, dimensionless

TABLE 1. SCREENING LIST OF CHEMICALS

CAS No.	Chemical	Is Chemical Sufficiently Toxic? ¹	Is Chemical Sufficiently Volatile? ²	Check Here if Known or Reasonably Suspected to be Present ³
83329	Acenaphthene	YES	YES	
75070	Acetaldehyde	YES	YES	
67641	Acetone	YES	YES	
75058	Acetronitrile	YES	YES	
98862	Acetophenone	YES	YES	
107028	Acrolein	YES	YES	
107131	Acrylonitrile	YES	YES	
309002	Aldrin	YES	YES	
319846	Alpha-HCH (alpha-BHC)	YES	YES	
62533	Aniline	YES	NO	NA
120127	Anthracene	NO	YES	NA
56553	Benz(a)anthracene	YES	NO	NA
100527	Benzaldehyde	YES	YES	
71432	Benzene	YES	YES	
50328	Benzo(a)pyrene	YES	NO	NA
205992	Benzo(b)fluoranthene	YES	YES	
207089	Benzo(k)fluoranthene	NO	NO	NA
65850	Benzoic Acid	NO	NO	NA
100516	Benzyl alcohol	YES	NO	NA
100447	Benzylchloride	YES	YES	
91587	Beta-Chloronaphthalene ³	YES	YES	
319857	Beta-HCH(beta-BHC)	YES	NO	NA
92524	Biphenyl	YES	YES	
111444	Bis(2-chloroethyl)ether	YES	YES	
108601	Bis(2-chloroisopropyl)ether ³	YES	YES	
117817	Bis(2-ethylhexyl)phthalate	NO	NO	NA
542881	Bis(chloromethyl)ether ³	YES	YES	
75274	Bromodichloromethane	YES	YES	
75252	Bromoform	YES	YES	
106990	1,3-Butadiene	YES	YES	
71363	Butanol	YES	NO	NA
85687	Butyl benzyl phthalate	NO	NO	NA
86748	Carbazole	YES	NO	NA
75150	Carbon disulfide	YES	YES	
56235	Carbon tetrachloride	YES	YES	
57749	Chlordane	YES	YES	

(continued)

CAS No.	Chemical	Is Chemical Sufficiently Toxic? ¹	Is Chemical Sufficiently Volatile? ²	Check Here if Known or Reasonably Suspected to be Present ³
126998	2-Chloro-1,3-butadiene(chloroprene)	YES	YES	
108907	Chlorobenzend	YES	YES	
109693	1-Chlorobutane	YES	YES	
124481	Chlorodibromomethane	YES	YES	
75456	Chlorodifluoromethane	YES	YES	
75003	Chloroethane (ethyl chloride)	YES	YES	
67663	Chloroform	YES	YES	
95578	2-Chlorophenol	YES	YES	
75296	2-Chloropropane	YES	YES	
218019	Chrysene	YES	YES	
156592	Cis-1,2-Dichloroethylene	YES	YES	
123739	Crotonaldehyde(2-butenal)	YES	YES	
998828	Cumene	YES	YES	
72548	DDD	YES	NO	NA
72559	DDE	YES	YES	
50293	DDT	YES	NO	NA
53703	Dibenz(a,h)anthracene	YES	NO	NA
132649	Dibenzofuran	YES	YES	
96128	1,2-Dibromo-3-chloropropane ³	YES	YES	
106934	1,2-Dibromoethane(ethylene dibromide)	YES	YES	
541731	1,3-Dichlorobenzene	YES	YES	
95501	1,2-Dichlorobenzene	YES	YES	
106467	1,4-Dichlorobenzene	YES	YES	
91941	3,3-Dichlorobenzidine	YES	NO	NA
75718	Dichlorodifluoromethane	YES	YES	
75343	1,1-Dichloroethane	YES	YES	
107062	1,2-dichloroethane	YES	YES	
75354	1,1-Dichloroethylene	YES	YES	
120832	2,4-Dichloroephenol	YES	NO	NA
78875	1,2-Dichloropropane	YES	YES	
542756	1,3-Dichloropropene	YES	YES	
60571	Dieldrin	YES	YES	
84662	Diethylphthalate	YES	NO	NA
105679	2,4-Dimethylphenol	YES	NO	NA
131113	Dimethylphthalate	NA	NO	NA
84742	Di-n-butyl phthalate	NO	NO	NA

(continued)

CAS No.	Chemical	Is Chemical Sufficiently Toxic? ¹	Is Chemical Sufficiently Volatile? ²	Check Here if Known or Reasonably Suspected to be Present ³
534521	4,6 Dinitro-2methylphenol (4, 6-dinitro-o-cresol)	YES	NO	NA
51285	2,4-Dinitrophenol	YES	NO	NA
121142	2,4-Dinitrotoluene	YES	NO	NA
606202	2,6-Dinitrotoluene	YES	NO	NA
117840	Di-n-octyl phthalate	NO	YES	NA
115297	Endosulfan	YES	YES	
72208	Endrin	YES	NO	NA
106898	Epichlorohydrin ³	YES	YES	
60297	Ethyl ether	YES	YES	
141786	Ethylacetate	YES	YES	
100414	Ethylbenzene	YES	YES	
75218	Ethylene oxide	YES	YES	
97632	Ethylmethacrylate	YES	YES	
206440	Fluoranthene	NO	YES	NA
86737	Fluorene	YES	YES	
110009	Furane	YES	YES	
58899	Gamma-HCH(Lindane)	YES	YES	
76448	Heptachlor	YES	YES	
1024573	Heptachlor epoxide	YES	NO	NA
87683	Hexachloro-1,3-butadiene	YES	YES	
118741	Hexachlorobenzene	YES	YES	
77474	Hexachlorocyclopentadiene	YES	YES	
67721	Hexachloroethane	YES	YES	
110543	Hexane	YES	YES	
74908	Hydrogene cyanide	YES	YES	
193395	Indeno (1,2,3-cd)pyrene	NO	NO	NA
78831	Isobutanol	YES	YES	
78591	Isophorone	YES	NO	NA
7439976	Mercury (elemental)	YES	YES	
126987	Methacrylonitrile	YES	YES	
72435	Methoxychlor	YES	YES	
79209	Methy acetate	YES	YES	
96333	Methyl acrylate	YES	YES	
74839	Methyl bromide	YES	YES	
74873	Methyl chloride (chloromethane)	YES	YES	
108872	Methylcyclohexane	YES	YES	

(continued)

CAS No.	Chemical	Is Chemical Sufficiently Toxic? ¹	Is Chemical Sufficiently Volatile? ²	Check Here if Known or Reasonably Suspected to be Present ³
74953	Methylene bromide	YES	YES	
75092	Methylene chloride	YES	YES	
78933	Methylethylketone (2-butanone)	YES	YES	
108101	Methylisobutylketone (4-methyl-2-pentanone)	YES	YES	
80626	Methylmethacrylate	YES	YES	
91576	2-Methylnaphthalene	YES	YES	
108394	3-Methylphenol(m-cresol)	YES	NO	NA
95487	2-Methylphenol(o-cresol)	YES	NO	NA
106455	4-Methylphenol (p-cresol)	YES	NO	NA
99081	m-Nitrotoluene	YES	NO	NA
1634044	MTBE	YES	YES	
108383	m-Xylene	YES	YES	
91203	Naphthalene	YES	YES	
104518	n-Butylbenzene	YES	YES	
98953	Nitrobenzene	YES	YES	
100027	4-Nitrophenol	YES	NO	NA
79469	2-Nitropropane	YES	YES	
924163	N-nitroso-di-n-butylamine ³	YES	YES	
621647	N-Nitroso-di-n-propylamine	YES	NO	NA
86306	N-Nitrosodiphenylamine	YES	NO	NA
103651	n-Propylbenzene	YES	YES	
88722	o-Nitrotoluene	YES	YES	
95476	o-Xylene	YES	YES	
106478	p-Chloroaniline	YES	NO	NA
87865	Pentachlorophenol	YES	NO	NA
108952	Phenol	YES	NO	NA
99990	p-Nitrotoluene	YES	NO	NA
106423	p-Xylene	YES	YES	
129000	Pyrene	YES	YES	
110861	Pyridine	YES	NO	NA
135988	Sec-Butylbenzene	YES	YES	
100425	Styrene	YES	YES	
98066	Tert-Butylbenzene	YES	YES	
630206	1,1,1,2-Tetrachloroethane	YES	YES	
79345	1,1,2,2,-Tetrachloroethane	YES	YES	
127184	Tetrachloroethylene	YES	YES	

(continued)

CAS No.	Chemical	Is Chemical Sufficiently Toxic? ¹	Is Chemical Sufficiently Volatile? ²	Check Here if Known or Reasonably Suspected to be Present ³
108883	Toluene	YES	YES	
8001352	Toxaphen	YES	NO	NA
156605	Trans-1,2-Dichloroethylene	YES	YES	
76131	1,1,2-Trichloro-1,2,2-trifluoroethane	YES	YES	
120821	1,2,4-Trichlorobenzene	YES	YES	
79005	1,1,2-Trichloroethane	YES	YES	
71556	1,1,1-Trichloroethane	YES	YES	
79016	Trichloroethylene	YES	YES	
75694	Trichlorofluoromethane	YES	YES	
95954	2,4,5-Trichlorophenol	YES	NO	NA
88062	2,4,6-Trichlorophenol	YES	NO	NA
96184	1,2,3-Trichloropropane	YES	YES	
95636	1,2,4-Trimethylbenzene	YES	YES	
108678	1,3,5-Trimethylbenzene	YES	YES	
108054	Vinyl acetate	YES	YES	
75014	Vinyl chloride (chloroethene)	YES	YES	

¹ A chemical is considered sufficiently toxic if the vapor concentration of the pure component poses an incremental lifetime cancer risk greater than 10^{-6} or a non-cancer hazard index greater than 1.

² A chemical is considered sufficiently volatile if its Henry's law constant is 1×10^{-5} atm-m³/mol or greater.

³ One or more of the physical chemical properties required to run the indoor air vapor intrusion models was not found during a literature search conducted March 2003.

- C_R = Initial soil concentration, g/g
 ρ_b = Soil dry bulk density, g/cm³
 θ_w = Soil water-filled porosity, cm³/cm³
 K_d = Soil-water partition coefficient, cm³/g (= K_{oc} x f_{oc})
 θ_a = Soil air-filled porosity, cm³/cm³
 K_{oc} = Soil organic carbon partition coefficient, cm³/g
 f_{oc} = Soil organic carbon weight fraction.

If the initial soil concentration includes a residual phase, the user is referred to the NAPL-SCREEN or NAPL-ADV models as discussed in Appendix A. These models estimate indoor air concentrations and associated risks for up to 10 user-defined contaminants that comprise a residual phase mixture in soils.

C_{source} for groundwater contamination is estimated assuming that the vapor and aqueous-phases are in local equilibrium according to Henry's law such that:

$$C_{source} = H'_{TS} C_w \quad (2)$$

where C_{source} = Vapor concentration at the source of contamination, g/cm³-v

H'_{TS} = Henry's law constant at the system (groundwater) temperature, dimensionless

C_w = Groundwater concentration, g/cm³-w.

The dimensionless form of the Henry's law constant at the system temperature (i.e., at the average soil/groundwater temperature) may be estimated using the Clapeyron equation by:

$$H'_{TS} = \frac{\exp\left[-\frac{\Delta H_{v,TS}}{R_c} \left(\frac{1}{T_S} - \frac{1}{T_R}\right)\right] H_R}{RT_S} \quad (3)$$

where H'_{TS} = Henry's law constant at the system temperature, dimensionless

$\Delta H_{v,TS}$ = Enthalpy of vaporization at the system temperature, cal/mol

- T_S = System temperature, °K
 T_R = Henry's law constant reference temperature, °K
 H_R = Henry's law constant at the reference temperature, atm-m³/mol
 R_C = Gas constant (= 1.9872 cal/mol - °K)
 R = Gas constant (= 8.205 E-05 atm-m³/mol-°K).

The enthalpy of vaporization at the system temperature can be calculated from Lyman et al. (1990) as:

$$\Delta H_{v,TS} = \Delta H_{v,b} \left[\frac{(1-T_S/T_C)}{(1-T_B/T_C)} \right]^n \quad (4)$$

- where $\Delta H_{v,TS}$ = Enthalpy of vaporization at the system temperature, cal/mol
 $\Delta H_{v,b}$ = Enthalpy of vaporization at the normal boiling point, cal/mol
 T_S = System temperature, °K
 T_C = Critical temperature, °K
 T_B = Normal boiling point, °K
 n = Constant, unitless.

Table 2 gives the value of n as a function of the ratio T_B/T_C .

TABLE 2. VALUES OF EXPONENT n AS A FUNCTION OF T_B/T_C

T_B/T_C	N
< 0.57	0.30
0.57 - 0.71	0.74 (T_B/T_C) - 0.116
> 0.71	0.41

2.3 DIFFUSION THROUGH THE CAPILLARY ZONE

Directly above the water table, a saturated capillary zone exists whereby groundwater is held within the soil pores at less than atmospheric pressure (Freeze and Cherry, 1979). Between drainage and wetting conditions, the saturated water content varies but is always less than the fully saturated water content which is equal to the soil total porosity. This is the result of air entrapment in the pores during the wetting process (Gillham, 1984). Upon rewetting, the air content of the capillary zone will be higher than after main drainage. Therefore, the air content will vary as a function of groundwater recharge and discharge. At the saturated water content, Freijer (1994) found that the relative vapor-phase diffusion coefficient was almost zero. This implies that all remaining air-filled soil pores are disconnected and thus blocked for gas diffusion. As the air-filled porosity increased, however, the relative diffusion coefficient indicated the presence of connected air-filled pores that corresponded to the air-entry pressure head. The air-entry pressure head corresponds with the top of the saturated capillary zone. Therefore, to allow for the calculation of the effective diffusion coefficient by lumping the gas-phase and aqueous-phase together, the water-filled soil porosity in the capillary zone ($\theta_{w,cz}$) is calculated at the air-entry pressure head (h) according to the procedures of Waitz et al. (1996) and the van Genuchten equation (van Genuchten, 1980) for the water retention curve:

$$\theta_{w,cz} = \theta_r + \frac{\theta_s - \theta_r}{\left[1 + (\alpha_1 h)^N\right]^M} \quad (5)$$

- where
- $\theta_{w,cz}$ = Water-filled porosity in the capillary zone, cm³/cm³
 - θ_r = Residual soil water content, cm³/cm³
 - θ_s = Saturated soil water content, cm³/cm³
 - α_1 = Point of inflection in the water retention curve where d θ_w /dh is maximal, cm⁻¹
 - h = Air-entry pressure head, cm (= 1/ α_1 and assumed to be positive)
 - N = van Genuchten curve shape parameter, dimensionless
 - M = 1 - (1/N).

With a calculated value of $\theta_{w,cz}$ within the capillary zone at the air-entry pressure head, the air-filled porosity within the capillary zone ($\theta_{a,cz}$) corresponding to the minimum value at which gas diffusion is relevant is calculated as the total porosity (n) minus $\theta_{w,cz}$.

Hers (2002) computed the SCS class average values of the water filled porosity and the height of the capillary zone SCS soil textural classifications. Table 3 provides the class average values for each of the SCS soil types. These data replace the mean values developed by Schaap and

Leij (1998) included in the previous U.S. Environmental Protection Agency (EPA) version of the J&E Models. With the class average values presented in Table 3, a general estimate can be made of the values of $\theta_{w,cz}$ and $\theta_{a,cz}$ for each soil textural classification.

The total concentration effective diffusion coefficient across the capillary zone (D_{cz}^{eff}) may then be calculated using the Millington and Quirk (1961) model as:

$$D_{cz}^{eff} = D_a \left(\theta_{a,cz}^{3.33} / n_{cz}^2 \right) + \left(D_w / H'_{TS} \right) \left(\theta_{w,cz}^{3.33} / n_{cz}^2 \right) \quad (6)$$

where

D_{cz}^{eff} = Effective diffusion coefficient across the capillary zone, cm^2/s

D_a = Diffusivity in air, cm^2/s

$\theta_{a,cz}$ = Soil air-filled porosity in the capillary zone, cm^3/cm^3

n_{cz} = Soil total porosity in the capillary zone, cm^3/cm^3

D_w = Diffusivity in water, cm^2/s

H'_{TS} = Henry's law constant at the system temperature, dimensionless

$\theta_{w,cz}$ = Soil water-filled porosity in the capillary zone, cm^3/cm^3 .

According to Fick's law of diffusion, the rate of mass transfer across the capillary zone can be approximated by the expression:

$$E = A(C_{source} - C_{g0})D_{cz}^{eff} / L_{cz} \quad (7)$$

where

E = Rate of mass transfer, g/s

A = Cross-sectional area through which vapors pass, cm^2

C_{source} = Vapor concentration within the capillary zone, g/cm^3-v

C_{g0} = A known vapor concentration at the top of the capillary zone, g/cm^3-v (C_{g0} is assumed to be zero as diffusion proceeds upward)

D_{cz}^{eff} = Effective diffusion coefficient across the capillary zone, cm^2/s

L_{cz} = Thickness of capillary zone, cm .

TABLE 3. CLASS AVERAGE VALUES OF THE VAN GENUCHTEN SOIL WATER RETENTION PARAMETERS FOR THE 12 SCS SOIL TEXTURAL CLASSIFICATIONS

Soil texture (USDA)	Saturated water content, θ_s	Residual water Content, θ_r	van Genuchten parameters		
			α_1 (1/cm)	N	M
Clay	0.459	0.098	0.01496	1.253	0.2019
Clay loam	0.442	0.079	0.01581	1.416	0.2938
Loam	0.399	0.061	0.01112	1.472	0.3207
Loamy sand	0.390	0.049	0.03475	1.746	0.4273
Silt	0.489	0.050	0.00658	1.679	0.4044
Silty loam	0.439	0.065	0.00506	1.663	0.3987
Silty clay	0.481	0.111	0.01622	1.321	0.2430
Silty clay loam	0.482	0.090	0.00839	1.521	0.3425
Sand	0.375	0.053	0.03524	3.177	0.6852
Sandy clay	0.385	0.117	0.03342	1.208	0.1722
Sandy clay loam	0.384	0.063	0.02109	1.330	0.2481
Sandy loam	0.387	0.039	0.02667	1.449	0.3099

The value of C_{source} is calculated using Equation 2; the value of A is assumed to be 1 cm^2 ; and the value of $D_{\text{cz}}^{\text{eff}}$ is calculated by Equation 6. What remains is a way to estimate a value for L_{cz} .

Lohman (1972) and Fetter (1994) estimated the rise of the capillary zone above the water table using the phenomenon of capillary such that water molecules are subject to an upward attractive force due to surface tension at the air-water interface and the molecular attraction of the liquid and solid phases. The rise of the capillary zone can thus be estimated using the equation for the height of capillary rise in a bundle of tubes of various diameters equivalent to the diameters between varying soil grain sizes. Fetter (1994) estimated the mean rise of the capillary zone as:

$$L_{\text{cz}} = \frac{2 \alpha_2 \text{COS } \lambda}{\rho_w g R} \quad (8)$$

where

- L_{cz} = Mean rise of the capillary zone, cm
- α_2 = Surface tension of water, g/s (= 73)
- λ = Angle of the water meniscus with the capillary tube, degrees (assumed to be zero)
- ρ_w = Density of water, g/cm³ (= 0.999)
- g = Acceleration due to gravity, cm/s² (= 980)
- R = Mean interparticle pore radius, cm

and;

$$R = 0.2D \quad (9)$$

where

- R = Mean interparticle pore radius, cm
- D = Mean particle diameter, cm.

Assuming that the default values of the parameters given in Equation 8 are for groundwater between 5° and 25°C, Equation 8 reduces to:

$$L_{\text{cz}} = \frac{0.15}{R} \quad (10)$$

Nielson and Rogers (1990) estimated the arithmetic mean particle diameter for each of the 12 SCS soil textural classifications at the mathematical centroid calculated from its classification area (Figure 3). Table 4 shows the centroid compositions and mean particle sizes of the 12 SCS soil textural classes.

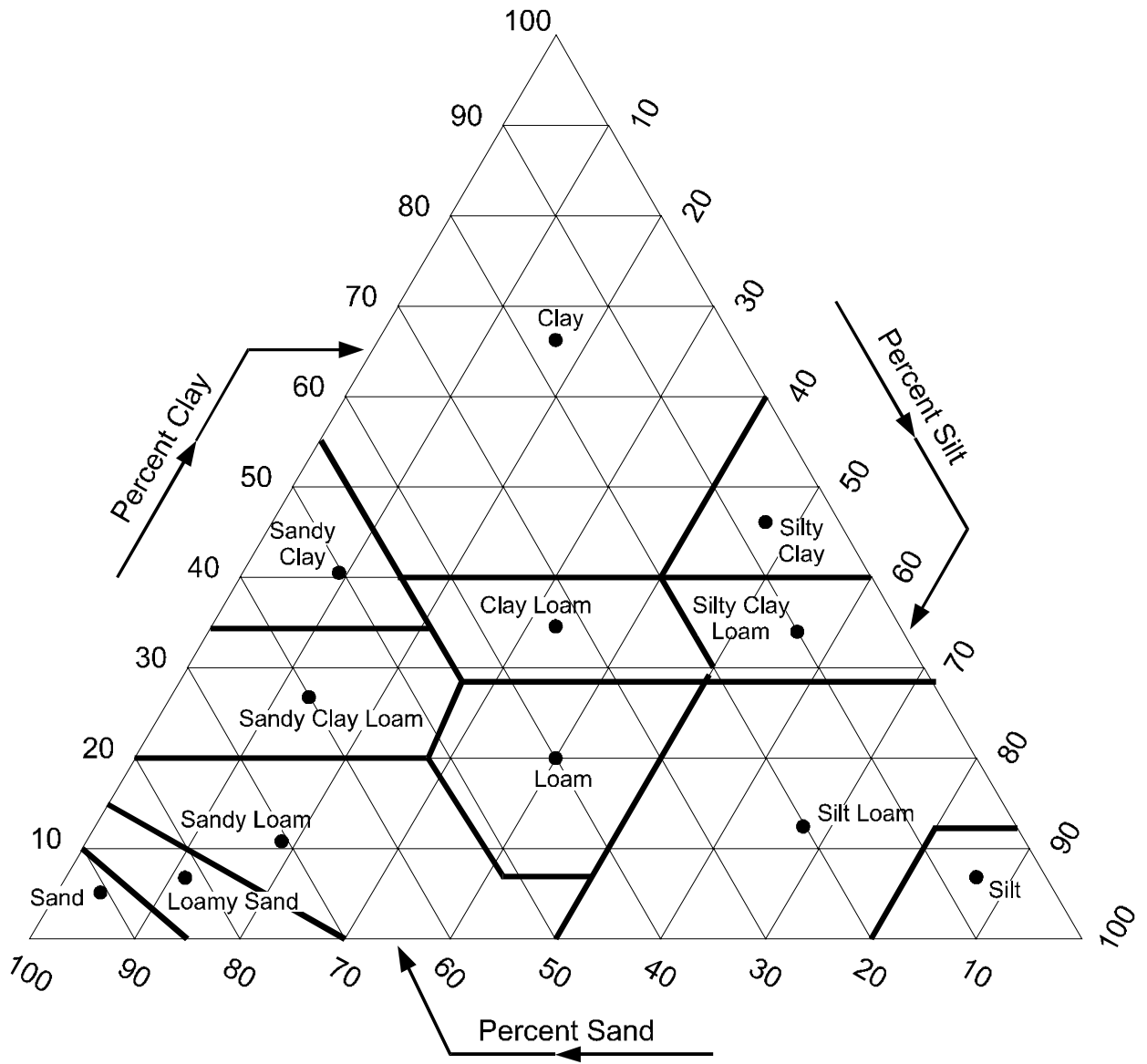

Figure 3. U.S. Soil Conservation Service Classification Chart Showing Centroid Compositions (Solid Circles)

TABLE 4. CENTROID COMPOSITIONS, MEAN PARTICLE DIAMETERS AND DRY BULK DENSITY OF THE 12 SCS SOIL TEXTURAL CLASSIFICATIONS

Textural class	% clay	% silt	% sand	Arithmetic mean particle diameter, cm	Dry Bulk Density g/cm ³
Sand	3.33	5.00	91.67	0.044	1.66
Loamy sand	6.25	11.25	82.50	0.040	1.62
Sandy loam	10.81	27.22	61.97	0.030	1.62
Sandy clay loam	26.73	12.56	60.71	0.029	1.63
Sandy clay	41.67	6.67	51.66	0.025	1.63
Loam	18.83	41.01	40.16	0.020	1.59
Clay loam	33.50	34.00	32.50	0.016	1.48
Silt loam	12.57	65.69	21.74	0.011	1.49
Clay	64.83	16.55	18.62	0.0092	1.43
Silty clay loam	33.50	56.50	10.00	0.0056	1.63
Silt	6.00	87.00	7.00	0.0046	1.35
Silty clay	46.67	46.67	6.66	0.0039	1.38

Given the mean particle diameter data in Table 4, the mean thickness of the capillary zone may then be estimated using Equations 9 and 10.

2.4 DIFFUSION THROUGH THE UNSATURATED ZONE

The effective diffusion coefficient within the unsaturated zone may also be estimated using the same form as Equation 6:

$$D_i^{eff} = D_a \left(\theta_{a,i}^{3.33} / n_i^2 \right) + (D_w / H'_{TS}) \left(\theta_{w,i}^{3.33} / n_i^2 \right) \quad (11)$$

where

- D_i^{eff} = Effective diffusion coefficient across soil layer i, cm^2/s
- D_a = Diffusivity in air, cm^2/s
- $\theta_{a,i}$ = Soil air-filled porosity of layer i, cm^3/cm^3
- n_i = Soil total porosity of layer i, cm^3/cm^3
- D_w = Diffusivity in water, cm^2/s
- $\theta_{w,i}$ = Soil water-filled porosity of layer i, cm^3/cm^3
- H'_{TS} = Henry's law constant at the system temperature, dimensionless

The overall effective diffusion coefficient for systems composed of n distinct soil layers between the source of contamination and the enclosed space floor is:

$$D_T^{eff} = \frac{L_T}{\sum_{i=0}^n L_i / D_i^{eff}} \quad (12)$$

where

- D_T^{eff} = Total overall effective diffusion coefficient, cm^2/s
- L_i = Thickness of soil layer i, cm
- D_i^{eff} = Effective diffusion coefficient across soil layer i, cm^2/s
- L_T = Distance between the source of contamination and the bottom of the enclosed space floor, cm.

Note that in the case of cracks in the floor of the enclosed space, the value of L_T does not include the thickness of the floor, nor does the denominator of Equation 12 include the thickness of the floor and the associated effective diffusion coefficient across the crack(s). An unlimited number of soil layers, including the capillary zone, may be included in Equation 12, but all layers must be located between the source of contamination and the enclosed space floor.

2.5 THE INFINITE SOURCE SOLUTION TO CONVECTIVE AND DIFFUSIVE TRANSPORT

Under the assumption that mass transfer is steady-state, J&E (1991) give the solution for the attenuation coefficient (α) as:

$$\alpha = \frac{\left[\left(\frac{D_T^{eff} A_B}{Q_{building} L_T} \right) x \exp\left(\frac{Q_{soil} L_{crack}}{D^{crack} A_{crack}} \right) \right]}{\left[\exp\left(\frac{Q_{soil} L_{crack}}{D_{crack} A_{crack}} \right) + \left(\frac{D_T^{eff} A_B}{Q_{building} L_T} \right) + \left(\frac{D_T^{eff} A_B}{Q_{soil} L_T} \right) \left[\exp\left(\frac{Q_{soil} L_{crack}}{D^{crack} A_{crack}} \right) - 1 \right] \right]} \quad (13)$$

where	α	= Steady-state attenuation coefficient, unitless
	D_T^{eff}	= Total overall effective diffusion coefficient, cm^2/s
	A_B	= Area of the enclosed space below grade, cm^2
	$Q_{building}$	= Building ventilation rate, cm^3/s
	L_T	= Source-building separation, cm
	Q_{soil}	= Volumetric flow rate of soil gas into the enclosed space, cm^3/s
	L_{crack}	= Enclosed space foundation or slab thickness, cm
	A_{crack}	= Area of total cracks, cm^2
	D_{crack}	= Effective diffusion coefficient through the cracks, cm^2/s (assumed equivalent to D_i^{eff} of soil layer i in contact with the floor).

The total overall effective diffusion coefficient is calculated by Equation 12. The value of A_B includes the area of the floor in contact with the underlying soil and the total wall area below grade. The building ventilation rate ($Q_{building}$) may be calculated as:

$$Q_{building} = (L_B W_B H_B ER) / 3,600 \text{ s / h} \quad (14)$$

where	$Q_{building}$	= Building ventilation rate, cm^3/s
	L_B	= Length of building, cm
	W_B	= Width of building, cm
	H_B	= Height of building, cm

ER = Air exchange rate, (1/h).

The building dimensions in Equation 14 are those dimensions representing the total "living" space of the building; this assumes that the total air volume within the structure is well mixed and that any vapor contaminant entering the structure is instantaneously and homogeneously distributed.

The volumetric flow rate of soil gas entering the building (Q_{soil}) is calculated by the analytical solution of Nazaroff (1988) such that:

$$Q_{soil} = \frac{2 \pi \Delta P k_v X_{crack}}{\mu \ln(2 Z_{crack} / r_{crack})} \quad (15)$$

where Q_{soil} = Volumetric flow rate of soil gas entering the building, cm^3/s

π = 3.14159

ΔP = Pressure differential between the soil surface and the enclosed space, $g/cm-s^2$

k_v = Soil vapor permeability, cm^2

X_{crack} = Floor-wall seam perimeter, cm

μ = Viscosity of air, $g/cm-s$

Z_{crack} = Crack depth below grade, cm

r_{crack} = Equivalent crack radius, cm.

Equation 15 is an analytical solution to vapor transport solely by pressure-driven air flow to an idealized cylinder buried some distance (Z_{crack}) below grade; the length of the cylinder is taken to be equal to the building floor-wall seam perimeter (X_{crack}). The cylinder, therefore, represents that portion of the building below grade through which vapors pass. The equivalent radius of the floor-wall seam crack (r_{crack}) is given in J&E (1991) as:

$$r_{crack} = \eta (A_B / X_{crack}) \quad (16)$$

where r_{crack} = Equivalent crack radius, cm

η = A_{crack}/A_B , ($0 \leq \eta \leq 1$)

A_B = Area of the enclosed space below grade, cm^2

X_{crack} = Floor-wall seam perimeter, cm.

The variable r_{crack} is actually the product of the fixed crack-to-total area ratio (η) and the hydraulic radius of the idealized cylinder, which is equal to the total area (A_B) divided by that portion of the cylinder perimeter in contact with the soil gas (X_{crack}). Therefore, if the dimensions of the enclosed space below grade (A_B) and/or the floor-wall seam perimeter (X_{crack}) vary, and the crack-to-total area ratio (η) remains constant, the value of r_{crack} must also vary. The total area of cracks (A_{crack}) is the product of η and A_B .

Equation 15 requires that the soil column properties within the zone of influence of the building (e.g., porosities, bulk density, etc.) be homogeneous, that the soil be isotropic with respect to vapor permeability, and that the pressure within the building be less than atmospheric.

Equation 13 contains the exponent of the following dimensionless group:

$$\left(\frac{Q_{\text{soil}} L_{\text{crack}}}{D_{\text{crack}} A_{\text{crack}}} \right) \cdot \quad (17)$$

This dimensionless group represents the equivalent Peclet number for transport through the building foundation. As the value of this group approaches infinity, the value of α approaches:

$$\frac{\left(\frac{D_T^{\text{eff}} A_B}{Q_{\text{building}} L_T} \right)}{\left(\frac{D_T^{\text{eff}} A_B}{Q_{\text{soil}} L_T} \right) + 1} \cdot \quad (18)$$

In the accompanying spreadsheets, if the exponent of Equation 17 is too great to be calculated, the value of α is set equal to Equation 18.

With a calculated value of α , the steady-state vapor-phase concentration of the contaminant in the building (C_{building}) is calculated as:

$$C_{\text{building}} = \alpha C_{\text{source}} \cdot \quad (19)$$

2.6 THE FINITE SOURCE SOLUTION TO CONVECTIVE AND DIFFUSIVE TRANSPORT

If the thickness of soil contamination is known, the finite source solution of J&E (1991) can be employed such that the time-averaged attenuation coefficient ($\langle\alpha\rangle$) may be calculated as:

$$\langle\alpha\rangle = \frac{\rho_b C_R \Delta H_c A_B}{Q_{building} C_{source} \tau} \left(\frac{L_T^0}{\Delta H_c} \right) \left[(\beta^2 + 2 \Psi \tau)^{1/2} - \beta \right] \quad (20)$$

where	$\langle\alpha\rangle$	= Time-averaged finite source attenuation coefficient, unitless
	ρ_b	= Soil dry bulk density at the source of contamination, g/cm ³
	C_R	= Initial soil concentration, g/g
	ΔH_c	= Initial thickness of contamination, cm
	A_B	= Area of enclosed space below grade, cm ²
	$Q_{building}$	= Building ventilation rate, cm ³ /s
	C_{source}	= Vapor concentration at the source of contamination, g/cm ^{3-v}
	τ	= Exposure interval, s
	L_T^0	= Source-building separation at time = 0, cm

and;

$$\beta = \left(\frac{D_T^{eff} A_B}{L_T^0 Q_{soil}} \right) \left[1 - \exp \left(- \frac{Q_{soil} L_{crack}}{D^{crack} A_{crack}} \right) \right] + 1 \quad (21)$$

and;

$$\Psi = \frac{D_T^{eff} C_{source}}{(L_T^0)^2 \rho_b C_R} \quad (22)$$

Implicit in Equation 20 is the assumption that source depletion occurs from the top boundary of the contaminated zone as contaminant volatilizes and moves upward toward the soil surface. This creates a hypothetical "dry zone" (δ) that grows with time; conversely, the "wet zone" of contamination retreats proportionally. When the thickness of the depletion zone (δ) is equal to the initial thickness of contamination (ΔH_c), the source is totally depleted. The unitless expression $(L_T^0/\Delta H_c)[(\beta^2 + 2\Psi\tau)^{1/2} - \beta]$ in Equation 20 represents the cumulative fraction of the depletion zone at the end of the exposure interval τ . Multiplying this expression by the remainder of Equation 20 results in the time-averaged finite source attenuation coefficient ($\langle\alpha\rangle$).

With a calculated value for $\langle\alpha\rangle$, the time-averaged vapor concentration in the building ($C_{building}$) is:

$$C_{building} = \langle\alpha\rangle C_{source} \quad (23)$$

For extended exposure intervals (e.g., 30 years), the time for source depletion may be less than the exposure interval. The time for source depletion (τ_D) may be calculated by:

$$\tau_D = \frac{[\Delta H_c / L_T^0 + \beta]^2 - \beta^2}{2\Psi} \quad (24)$$

If the exposure interval (τ) is greater than the time for source depletion (τ_D), the time-averaged building vapor concentration may be calculated by a mass balance such that:

$$C_{building} = \frac{\rho_b C_R \Delta H_c A_B}{Q_{building} \tau} \quad (25)$$

where $C_{building}$ = Time-averaged vapor concentration in the building, g/cm³-v

ρ_b = Soil dry bulk density at the source of contamination, g/cm³

C_R = Initial soil concentration, g/g

ΔH_c = Initial thickness of contamination, cm

A_B = Area of enclosed space below grade, cm²

$Q_{building}$ = Building ventilation rate, cm³/s

τ = Exposure interval, s.

2.7 THE SOIL GAS MODELS

Use of the J&E Model has typically relied on a theoretical partitioning of the total volume soil concentration into the sorbed, aqueous, and vapor phases. The model has also relied on a theoretical approximation of vapor transport by diffusion and convection from the source of emissions to the building floor in contact with the soil. Use of measured soil gas concentrations directly beneath the building floor instead of theoretical vapor concentrations and vapor transport has obvious advantages that would help to reduce the uncertainty in the indoor air concentration estimates made by the model.

The soil gas models (SG-SCREEN and SG-ADV) are designed to allow the user to input measured soil gas concentration and sampling depth information directly into the spreadsheets. In the new models, the value of the user-defined soil gas concentration is assigned as the value of C_{source} in Equation 19. The steady-state (infinite source) attenuation coefficient (α) in Equation 19 is calculated using Equation 13. The steady-state solution for the attenuation coefficient is used because no evaluation has been made regarding the size and total mass of the source of emissions. The source of emissions, therefore, cannot be depleted over time. The soil gas models estimate the steady-state indoor air concentration over the exposure duration. For a detailed discussion of using the soil gas models as well as soil gas sampling, see Section 4 of this document.

2.8 SOIL VAPOR PERMEABILITY

Soil vapor permeability (k_v) is one of the most sensitive model parameters associated with convective transport of vapors within the zone of influence of the building. Soil vapor permeability is typically measured from field pneumatic tests. If field data are lacking, however, an estimate of the value of k_v can be made with limited data.

Soil intrinsic permeability is a property of the medium alone that varies with the size and shape of connected soil pore openings. Intrinsic permeability (k_i) can be estimated from the soil saturated hydraulic conductivity:

$$k_i = \frac{K_s \mu_w}{\rho_w g} \quad (26)$$

where

- k_i = Soil intrinsic permeability, cm^2
- K_s = Soil saturated hydraulic conductivity, cm/s
- μ_w = Dynamic viscosity of water, g/cm-s (= 0.01307 at 10°C)
- ρ_w = Density of water, g/cm^3 (= 0.999)

g = Acceleration due to gravity, cm/s^2 (= 980.665).

Schaap and Leij (1998) computed the SCS class average values of the saturated hydraulic conductivity (K_s) for each of the 12 SCS soil textural classifications (Table 5). With these values, a general estimate of the value of k_i can be made by soil type. As an alternative, in situ measurements of the site-specific saturated hydraulic conductivity can be made and the results input into Equation 26 to compute the value of the soil intrinsic permeability.

Effective permeability is the permeability of the porous medium to a fluid when more than one fluid is present; it is a function of the degree of saturation. The relative air permeability of soil (k_{rg}) is the effective air permeability divided by the intrinsic permeability and therefore takes into account the effects of the degree of water saturation on air permeability.

TABLE 5. CLASS AVERAGE VALUES OF SATURATED HYDRAULIC CONDUCTIVITY FOR THE 12 SCS SOIL TEXTURAL CLASSIFICATIONS

Soil texture , USDA	Class average saturated hydraulic conductivity, cm/h
Sand	26.78
Loamy sand	4.38
Sandy loam	1.60
Sandy clay loam	0.55
Sandy clay	0.47
Loam	0.50
Clay loam	0.34
Silt loam	0.76
Clay	0.61
Silty clay loam	0.46
Silt	1.82
Silty clay	0.40

Parker et al. (1987) extended the relative air permeability model of van Genuchten (1980) to allow estimation of the relative permeabilities of air and water in a two- or three-phase system:

$$k_{rg} = (1 - S_{te})^{1/2} (1 - S_{te}^{1/M})^{2M} \quad (27)$$

where k_{rg} = Relative air permeability, unitless ($0 \leq k_{rg} \leq 1$)

S_{te} = Effective total fluid saturation, unitless

M = van Genuchten shape parameter, unitless.

Given a two-phase system (i.e., air and water), the effective total fluid saturation (S_{te}) is calculated as:

$$S_{te} = \frac{(\theta_w - \theta_r)}{(n - \theta_r)} \quad (28)$$

where S_{te} = Effective total fluid saturation, unitless

θ_w = Soil water-filled porosity, cm^3/cm^3

θ_r = Residual soil water content, cm^3/cm^3

n = Soil total porosity, cm^3/cm^3 .

Class average values for the parameters θ_r and M by SCS soil type may be obtained from Table 3.

The effective air permeability (k_v) is then the product of the intrinsic permeability (k_i) and the relative air permeability (k_{rg}) at the soil water-filled porosity θ_w .

2.9 CALCULATION OF A RISK-BASED SOIL OR GROUNDWATER CONCENTRATION

Both the infinite source model estimate of the steady-state building concentration and the finite source model estimate of the time-averaged building concentration represent the exposure point concentration used to assess potential risks. Calculation of a risk-based media concentration for a carcinogenic contaminant takes the form:

$$C_c = \frac{TR \times AT_c \times 365 \text{ days / yr}}{URF \times EF \times ED \times C_{building}} \quad (29)$$

where C_c = Risk-based media concentration for carcinogens, $\mu\text{g}/\text{kg}$ -soil, or $\mu\text{g}/\text{L}$ -water

TR = Target risk level, unitless

AT_c = Averaging time for carcinogens, yr

URF = Unit risk factor, $(\mu\text{g}/\text{m}^3)^{-1}$

EF = Exposure frequency, days/yr

ED = Exposure duration, yr

C_{building} = Vapor concentration in the building, $\mu\text{g}/\text{m}^3$ per $\mu\text{g}/\text{kg}$ -soil,
or $\mu\text{g}/\text{m}^3$ per $\mu\text{g}/\text{L}$ -water.

In the case of a noncarcinogenic contaminant, the risk-based media concentration is calculated by:

$$C_{\text{NC}} = \frac{\text{THQ} \times \text{AT}_{\text{NC}} \times 365 \text{ days / yr}}{\text{EF} \times \text{ED} \times \frac{1}{\text{RfC}} \times C_{\text{building}}} \quad (30)$$

where

- C_{NC} = Risk-based media concentration for noncarcinogens, $\mu\text{g}/\text{kg}$ -soil, or $\mu\text{g}/\text{L}$ -water
- THQ = Target hazard quotient, unitless
- AT_{NC} = Averaging time for noncarcinogens, yr
- EF = Exposure frequency, days/yr
- ED = Exposure duration, yr
- RfC = Reference concentration, mg/m^3
- C_{building} = Vapor concentration in the building, mg/m^3 per $\mu\text{g}/\text{kg}$ -soil, or mg/m^3 per $\mu\text{g}/\text{L}$ -water.

The spreadsheets calculate risk-based media concentrations based on a unity initial concentration. That is, soil risk-based concentrations are calculated with an initial hypothetical soil concentration of 1 $\mu\text{g}/\text{kg}$ -soil, while for groundwater the initial hypothetical concentration is 1 $\mu\text{g}/\text{L}$ -water.

For this reason, the values of C_{source} and C_{building} shown on the INTERCALCS worksheet when reverse-calculating a risk-based media concentration do not represent actual values. For these calculations, the following message will appear on the RESULTS worksheet:

"MESSAGE: The values of C_{source} and C_{building} on the INTERCALCS worksheet are based on unity and do not represent actual values."

When forward-calculating risks from a user-defined initial soil or groundwater concentration, the values of C_{source} and C_{building} on the INTERCALCS worksheet are correct.

2.10 CALCULATION OF INCREMENTAL RISKS

Forward-calculation of incremental risks begins with an actual initial media concentration (i.e., $\mu\text{g}/\text{kg}$ -soil or $\mu\text{g}/\text{L}$ -water). For carcinogenic contaminants, the risk level is calculated as:

$$Risk = \frac{URF \times EF \times ED \times C_{building}}{AT_C \times 365 \text{ days} / \text{yr}} \quad (31)$$

For noncarcinogenic contaminants, the hazard quotient (HQ) is calculated as:

$$HQ = \frac{EF \times ED \times \frac{1}{RfC} \times C_{building}}{AT_{NC} \times 365 \text{ days} / \text{yr}} \quad (32)$$

2.11 MAJOR MODEL ASSUMPTIONS/LIMITATIONS

The following represent the major assumptions/limitations of the J&E Model.

1. Contaminant vapors enter the structure primarily through cracks and openings in the walls and foundation.
2. Convective transport occurs primarily within the building zone of influence and vapor velocities decrease rapidly with increasing distance from the structure.
3. Diffusion dominates vapor transport between the source of contamination and the building zone of influence.
4. All vapors originating from below the building will enter the building unless the floors and walls are perfect vapor barriers.
5. All soil properties in any horizontal plane are homogeneous.
6. The contaminant is homogeneously distributed within the zone of contamination.
7. The areal extent of contamination is greater than that of the building floor in contact with the soil.
8. Vapor transport occurs in the absence of convective water movement within the soil column (i.e., evaporation or infiltration), and in the absence of mechanical dispersion.
9. The model does not account for transformation processes (e.g., biodegradation, hydrolysis, etc.).

10. The soil layer in contact with the structure floor and walls is isotropic with respect to permeability.
11. Both the building ventilation rate and the difference in dynamic pressure between the interior of the structure and the soil surface are constant values.

Use of the J&E Model as a first-tier screening tool to identify sites needing further assessment requires careful evaluation of the assumptions listed in the previous section to determine whether any conditions exist that would render the J&E Model inappropriate for the site. If the model is deemed applicable at the site, care must be taken to ensure reasonably conservative and self-consistent model parameters are used as input to the model. Considering the limited site data typically available in preliminary site assessments, the J&E Model can be expected to predict only whether or not a risk-based exposure level will be exceeded at the site. Precise prediction of concentration levels is not possible with this approach.

The suggested minimum site characterization information for a first tier evaluation of the vapor intrusion pathway includes: site conceptual model, nature and extent of contamination distribution, soil lithologic descriptions, groundwater concentrations, and/or possibly near source soil vapor concentrations. The number of samples and measurements needed to establish this information varies by site and it's not possible to provide a hard and fast rule. Bulk soil concentrations should not be used unless appropriately preserved during sampling.

Based on the conceptual site model (CSM), the user can select the appropriate spreadsheet corresponding to the vapor source at the site and determine whether to use the screening level spreadsheet (which allows only one soil type above the capillary fringe) or the more advanced version (which allows up to three layers above the capillary fringe). Because most of the inputs to the J&E Model are not collected during a typical site characterization, conservative inputs have to be estimated or inferred from available data and other non-site-specific sources of information.

The uncertainty in determining key model parameters and sensitivity of the J&E Model to those key model parameters is qualitatively described in Table 6. As shown in the table, building-related parameters will moderate to high uncertainty and model sensitivity include: Q_{soil} , building crack ratio, building air-exchange rate, and building mixing height. Building-related parameters with low uncertainty and sensitivity include: foundation area, depth to base of foundation, and foundation slab thickness. Of the soil-dependent properties, the soil moisture parameters clearly are of critical importance for the attenuation value calculations.

TABLE 6. UNCERTAINTY AND SENSITIVITY OF KEY PARAMETERS FOR THE VAPOR INTRUSION MODEL

Input Parameter	Parameter Uncertainty Or Variability	Parameter Sensitivity			Deeper Contamination Building Not Underpressurized
		Shallower Contamination Building Underpressurized	Deeper Contamination Building Underpressurized	Shallower Contamination Building Not Underpressurized	
Soil Total Porosity (n)	Low	Low	Low	Low	Low
Soil Water-filled Porosity (θ_w)	Moderate to High	Low to Moderate	Moderate to High	Moderate to High	Moderate to High
Capillary Zone Water-filled Porosity ($\theta_{n,cz}$)	Moderate to High	Moderate to High	Moderate to High	Moderate to High	Moderate to High
Thickness of Capillary Zone (L_{cz})	Moderate to High	Moderate to High	Moderate to High	Moderate to High	Moderate to High
Soft Dry Bulk Density (ρ_b)	Low	Low	Low	Low	Low
Average Vapor Flowrate into a Building (Q_{soil})	High	Moderate to High	Low to Moderate	N/A	N/A
Soil Vapor Permeability(K_v)	High	Moderate to High	Low to Moderate	N/A	N/A
Soil to Building Pressure Differential (ΔP)	Moderate	Moderate	Low to Moderate	N/A	N/A
Henry's Law Constant (for single chemical) (H)	Low to Moderate	Low to Moderate	Low to Moderate	Low to Moderate	Low to Moderate
Diffusivity in Air (D_A)	Low	Low	Low	Low	Low
Indoor Air Exchange Rate (ER)	Moderate	Moderate	Moderate	Moderate	Moderate
Enclosed Space Height (H_B)	Moderate	Moderate	Moderate	Moderate	Moderate
Area of Enclosed Space Below Grade (A_B)	Low to Moderate	Low to Moderate	Low to Moderate	Low to Moderate	Low to Moderate
Depth Below Grade to Bottom of Enclosed Space (L_F)	Low	Low	Low	Low	Low
Crack-to-Total Area Ratio (η)	High	Low	Low	Moderate to High	Low to Moderate
Enclosed Space Floor Thickness (L_{crack})	Low	Low	Low	Low	Low

SECTION 3

SOIL AND GROUNDWATER MODEL APPLICATION

This section provides step-by-step instructions on how to implement the soil and groundwater contamination versions of the J&E Model using the spreadsheets. This section also discusses application of the soil gas versions of the model. The user provides data and selects certain input options, and views model results via a series of worksheets. Error messages are provided within both the data entry worksheet and the results worksheet to warn the user that entered data are missing or outside of permitted limits.

The J&E Model as constructed within the accompanying spreadsheets requires a range of input variables depending on whether a screening-level or advanced model is chosen. Table 7 provides a list of all major input variables, the range of practical values for each variable, the default value for each variable, and the relative model sensitivity and uncertainty of each variable. Table 7 also includes references for each value or range of values.

Table 8 indicates the results of an increase in the value of each input parameter. The results are shown as either an increase or a decrease in the building concentration (C_{building}) of the pollutant. An increase in the building concentration will result in an increase in the risk when forward-calculating from an initial soil or groundwater concentration. When reverse-calculating to a risk-based “acceptable” soil or groundwater concentration, an increase in the hypothetical unit building concentration will result in a lower “acceptable” soil or groundwater concentration.

A list of reasonably conservative model input parameters for building-related parameters is provided in Table 9, which also provides the practical range, typical or mean value (if applicable), and most conservative value for these parameters. For building parameters with low uncertainty and sensitivity, only a single “fixed” value corresponding to the mean or typical value is provided in Table 9. Soil-dependent properties are provided in Table 10 for soils classified according to the US SCS system. If site soils are not classified according to the US SCS, Table 11 can be used to assist in selecting an appropriate SCS soil type corresponding to the available site lithologic information. Note that the selection of the soil texture class should be biased towards the coarsest soil type of significance, as determined by the site characterization program.

TABLE 7. RANGE OF VALUES FOR SELECTED INPUT PARAMETERS

Input parameter	Practical range of values	Default value
Soil water-filled porosity (θ_w)	0.04 – 0.33 cm ³ /cm ^{3a}	Soil dependent see Table 10
Soil vapor permeability (k_v)	10 ⁻⁶ – 10 ⁻¹² cm ^{2b,c}	10 ⁻⁸ cm ^{2d}
Soil-building pressure differential (ΔP)	0 – 20 Pa ³	4 Pa ^f
Media initial concentration (C_R, C_w)	User-defined	NA
Depth to bottom of soil contamination (L_b)	User-defined	NA
Depth to top of concentration (L_T)	User-defined	NA
Floor-wall seam gap (w)	0.05 – 1.0 cm ^e	0.1 cm ^e
Soil organic carbon fraction (f_{oc})	0.001 – 0.006 ^a	0.002 ^a
Indoor air exchange rate (ER)	0.18 – 1.26 (H ⁻¹) ^g	0.25 (h ⁻¹) ^{g,h}
Soil total porosity (n)	0.34 – 0.53 cm ³ /cm ^{3a}	0.43 cm ³ /cm ^{3a}
Soil dry bulk density (ρ_b)	1.25 – 1.75 g/cm ^{3a}	1.5 g/cm ^{3a}

^aU.S. EPA (1996a and b).

^bJohnson and Ettinger (1991).

^cNazaroff (1988).

^dBased on transition point between diffusion and convection dominated transport from Johnson and Ettinger (1991).

^eEaton and Scott (1984); Loureiro et al. (1990).

^fLoureiro et al. (1990); Grimsrud et al. (1983).

^gKoontz and Rector (1995).

^hParker et al. (1990).

ⁱU.S. DOE (1995).

TABLE 8. EFFECT ON BUILDING CONCENTRATION FROM AN INCREASE IN INPUT PARAMETER VALUES

Input parameter	Change in parameter value	Effect on building concentration
Soil water-filled porosity (θ_w)	Increase	Decrease
Soil vapor permeability (k_v)	Increase	Increase
Soil-building pressure differential (ΔP)	Increase	Increase
Media initial concentration (C_R, C_w) ^a	Increase	Increase
Depth to bottom of soil contamination (L_b) ^b	Increase	Increase
Depth to top of concentration (L_T)	Increase	Decrease
Floor-wall seam gap (w)	Increase	Increase
Soil organic carbon fraction (f_{oc})	Increase	Decrease
Indoor air exchange rate (ER)	Increase	Decrease
Building volume ^c ($L_B \times W_B \times H_B$)	Increase	Decrease
Soil total porosity (n)	Increase	Increase
Soil dry bulk density (ρ_b)	Increase	Decrease

^a This parameter is applicable only when forward-calculating risk.

^b Applicable only to advanced model for soil contamination.

^c Used with building air exchange rate to calculate building ventilation rate.

TABLE 9. BUILDING-RELATED PARAMETERS FOR THE VAPOR INTRUSION MODEL

Input Parameter	Units	Fixed or Variable	Typical or Mean Value	Range	Conservative Value	Default Value
Total Porosity	cm ³ /cm ³	Fixed	Specific to soil texture, see Table 10			
Unsaturated Zone Water-filled Porosity	cm ³ /cm ³	Variable	Specific to soil texture, see Table 10			
Capillary Transition zone Water-filled Porosity	cm ³ /cm ³	Fixed	Specific to soil texture, see Table 10			
Capillary Transition Zone height	cm ³ /cm ³	Fixed	Specific to soil texture, see Table 10			
Q _{soil}	L/min	Variable	Specific to soil texture, see Table 10			
Soil air permeability	m ²	Variable	Specific to soil texture, see Table 10			
Building Depressurization	Pa	Variable	4	0-15	15	N/A
Henry's law constant (for single chemical)	-	Fixed	Specific to chemical, see Appendix B			
Free-Air Diffusion Coefficient (single chemical)	-	Fixed	Specific to chemical, see Appendix B			
Building Air exchange Rate	hr ⁻¹	Variable	0.5	0.1-1.5	0.1	0.25
Building Mixing height – Basement scenario	m	Variable	3.66	2.44-4.88	2.44	3.66
Building Mixing height – Slab-on-grade scenario	m	Variable	2.44	2.13-3.05	2.13	2.44
Building Footprint Area – Basement Scenario	m ²	Variable	120	80-200+	80	100
Building Footprint Area – Slab-on-Grade Scenario	m ²	Variable	120	80-200+	80	100
Subsurface Foundation area – Basement Scenario	m ²	Variable	208	152-313+	152	180
Subsurface Foundation area – Slab-on-Grade Scenario	m ²	Fixed	127	85-208+	85	106
Depth to Base of Foundation – Basement Scenario	m	Fixed	2	N/A	N/A	2
Depth to Base of Foundation – Slab-on-Grade Scenario	m	Fixed	0.15	N/A	N/A	0.15
Perimeter Crack Width	mm	Variable	1	0.5-5	5	1
Building Crack ratio – Slab-on-Grade Scenario	dimensionless	Variable	0.00038	0.00019-0.0019	0.0019	3.77 x 10 ⁻⁴
Building Crack ratio – Basement Scenario	dimensionless	Variable	0.0002	0.0001-0.001	0.001	2.2 x 10 ⁻⁴
Crack Dust Water-Filled Porosity	cm ³ /cm ³	Fixed	Dry	N/A	N/A	Dry
Building Foundation Slab Thickness	m	Fixed	0.1	N/A	N/A	0.1

TABLE 10. SOIL-DEPENDENT PROPERTIES FOR THE VAPOR INTRUSION MODEL - FIRST TIER ASSESSMENT

U.S. Soil Conservation Service (SCS) Soil Texture	Saturated		Unsaturated Zone				Capillary Transition Zone		
	Water Content Total Porosity θ_s (cm ³ /cm ³)	Residual Water Content θ_r (cm ³ /cm ³)	Water-Filled Porosity				Saturated Water Content Total Porosity θ_s (cm ³ /cm ³)	$\theta_{w, cap}$ @ air-entry	Height Cap Zone Fetter (94) (cm)
			Mean or Typical ($FC_{1/3bar} + \theta_r$)/2 $\theta_{w, unsat}$ (cm ³ /cm ³)	Range $\theta_{w, unsat}$ (cm ³ /cm ³)	Conservative $\theta_{w, unsat}$ (cm ³ /cm ³)	Modeled $\theta_{w, unsat}$ (cm ³ /cm ³)			
Clay	0.459	0.098	0.215	0.098-0.33	0.098	0.215	0.459	0.412	81.5
Clay Loam	0.442	0.079	0.168	0.079-0.26	0.079	0.168	0.442	0.375	46.9
Loam	0.399	0.061	0.148	0.061-0.24	0.061	0.148	0.399	0.332	37.5
Loamy Sand	0.39	0.049	0.076	0.049-0.1	0.049	0.076	0.39	0.303	18.8
Silt	0.489	0.05	0.167	0.05-0.28	0.050	0.167	0.489	0.382	163.0
Silt Loam	0.439	0.065	0.180	0.065-0.3	0.065	0.180	0.439	0.349	68.2
Silty Clay	0.481	0.111	0.216	0.11-0.32	0.111	0.216	0.481	0.424	192.0
Silty Clay Loam	0.482	0.09	0.198	0.09-0.31	0.090	0.198	0.482	0.399	133.9
Sand	0.375	0.053	0.054	0.053-0.055	0.053	0.054	0.375	0.253	17.0
Sandy Clay	0.385	0.117	0.197	0.117-0.28	0.117	0.197	0.385	0.355	30.0
Sandy Clay Loam	0.384	0.063	0.146	0.063-0.23	0.063	0.146	0.384	0.333	25.9
Sandy Loam	0.387	0.039	0.103	0.039-0.17	0.039	0.103	0.387	0.320	25.0
Loamy Sand	0.39	0.049	0.076	0.049-0.1	0.049	0.076	0.39	0.303	18.8

TABLE 11. GUIDANCE FOR SELECTION OF SOIL TYPE

If your boring log indicates that the following materials are the predominant soil types ...	Then you should use the following texture classification when obtaining the attenuation factor
Sand or Gravel or Sand and Gravel, with less than about 12 % fines, where “fines” are smaller than 0.075 mm in size.	Sand
Sand or Silty Sand, with about 12 % to 25 % fines	Loamy Sand
Silty Sand, with about 20 % to 50 % fines	Sandy Loam
Silt and Sand or Silty Sand or Clayey, Silty Sand or Sandy Silt or Clayey, Sandy Silt, with about 45 to 75 % fines	Loam
Sandy Silt or Silt, with about 50 to 85 % fines	Silt Loam

These input parameters were developed from the best available soil-physics science, available studies of building characteristics, and international-expert opinion. Consequently, the input parameters listed in Tables 9 and 10 are considered default parameters for a first-tier assessment, which should in most cases provide a reasonably (but not overly) conservative estimate of the vapor intrusion attenuation factor for a site. Justification for the building-related and soil-dependent parameters values selected as default values for the J&E Model is described below.

3.1 JUSTIFICATION OF DEFAULT SOIL-DEPENDENT PROPERTIES

The default soil-dependent parameters recommended for a first tier assessment (Table 10) represent mean or typical values, rather than the most conservative value, in order to avoid overly conservative estimates of attenuation factors. Note, however, that the range of values for some

soil properties can be very large, particularly in the case of moisture content and hydraulic conductivity. Consequently, selecting a soil type and corresponding typical soil property value may not accurately or conservatively represent a given site. Note also that Table 9 does not provide estimates of soil properties for very coarse soil types, such as gravel, gravelly sand, and sandy gravel, etc., which also may be present in the vadose zone. Consequently, in cases where the vadose zone is characterized by very coarse materials, the J&E Model may not provide a conservative estimate of attenuation factor.

As discussed above, the J&E Model is sensitive to the value of soil moisture content. Unfortunately, there is little information available on measured moisture contents below buildings. Therefore, the typical approach is to use a water retention model (e.g., van Genuchten model) to approximate moisture contents. For the unsaturated zone, the selected default value for soil moisture is a value equal to halfway between the residual saturation value and field capacity, using the van Genuchten model-predicted values for U.S. SCS soil types. For the capillary transition zone, a moisture content corresponding to the air entry pressure head is calculated by using the van Genuchten model. When compared to other available water retention models, the van Genuchten model yields somewhat lower water contents, which results in more conservative estimates of attenuation factor. The soil moisture contents listed in Table 10 are based on agricultural samples, which are likely to have higher water contents than soils below building foundations and, consequently result in less-conservative estimates of the attenuation factor.

3.2 JUSTIFICATION OF DEFAULT BUILDING-RELATED PROPERTIES

Building Air Exchange Rate (Default Value = 0.25 AEH)

The results of 22 studies for which building air exchange rates are reported in Hers et al. (2001). Ventilation rates vary widely from approximately 0.1 AEH for energy efficient “air-tight” houses (built in cold climates) (Fellin and Otson, 1996) to over 2 AEH (AHRAE (1985); upper range). In general, ventilation rates will be higher in summer months when natural ventilation rates are highest. Murray and Burmaster (1995) conducted one of the most comprehensive studies of U.S. residential air exchange rates (sample size of 2844 houses). The data set was analyzed on a seasonal basis and according to climatic region. When all the data were analyzed, the 10th, 50th and 90th percentile values were 0.21, 0.51 and 1.48 AEH. Air exchange rates varied depending on season and climatic region. For example, for the winter season and coldest climatic area (Region 1, e.g., Great Lakes area and extreme northeast U.S.), the 10th, 50th, and 90th percentile values were 0.11, 0.27 and 0.71 AEH, respectively.. In contrast, for the winter season and warmest climatic area [Region 4 (southern California, Texas, Florida, Georgia)], the 10th, 50th, and 90th percentile values were 0.24, 0.48 and 1.13 AEH, respectively. Although building air exchange rates would be higher during the summer months, vapor intrusion during winter months (when house depressurization is expected to be most significant) would be of greatest concern. For this guidance, a default value of 0.25 for air exchange rate was selected to represent the lower end of these distributions.

Crack Width and Crack Ratio (Default Value = 0.0002 for basement house; = 0.0038 for slab-on-grade house)

The crack width and crack ratio are related. Assuming a square house and that the only crack is a continuous edge crack between the foundation slab and wall (“perimeter crack”), the crack ratio and crack width are related as follows:

$$\text{Crack Ratio} = \text{Crack Width} \times 4 \times (\text{Subsurface Foundation Area})^{0.5} / \text{Subsurface Foundation Area}$$

Little information is available on crack width or crack ratio. One approach used by radon researchers is to back-calculate crack ratios using a model for soil gas flow through cracks and the results of measured soil gas flow rates into a building. For example, the back-calculated values for a slab/wall edge crack based on soil gas-entry rates reported in Nazaroff (1992), Revzan *et al.* (1991), and Nazaroff *et al.* (1985) range from about 0.0001 to 0.001. Another possible approach is to measure crack openings although this, in practice, is difficult to do. Figley and Snodgrass (1992) present data from 10 houses where edge crack measurements were made. At the eight houses where cracks were observed, the crack widths ranged from hairline cracks up to 5 mm wide, while the total crack length per house ranged from 2.5 m to 17.3 m. Most crack widths were less than 1 mm. The suggested defaults for crack ratio in regulatory guidance, literature, and models also vary. In ASTM E1739-95, a default crack ratio of 0.01 is used. The crack ratios suggested in the VOLASOIL model (developed by the Dutch Ministry of Environment) range from 0.0001 to 0.000001. The VOLASOIL model values correspond to values for a “good” and “bad” foundation, respectively. The crack ratio used by J&E (1991) for illustrative purposes ranged from 0.001 to 0.01. The selected default values fall within the ranges observed.

Building Area and Subsurface Foundation Area (Default Value = 10 m by 10 m)

The default building area is based on the following information:

- Default values used in the Superfund User’s Guide (9.61 m by 9.61 m or 92.4 m²)
- Default values used by the State of Michigan, as documented in Part 201, Generic Groundwater and Soil Volatilization to Indoor Air Inhalation Criteria: Technical Support Document (10.5 m by 10.5 m of 111.5 m²).

The Michigan guidance document indicates that the 111.5 m² area approximately corresponds to the 10th percentile floor space area for a residential single-family dwelling, based on statistics compiled by the U.S. Department of Commerce (DOC) and U.S. Housing and Urban Development (HUD). The typical, upper, and lower ranges presented in Table 9 are subjectively chosen values. The subsurface foundation area is a function of the building area, and depth to the base of the foundation, which is fixed.

Building Mixing Height (Default Value = 2.44 m for slab-on-grade scenario; = 3.66 m for basement scenario)

The J&E Model assumes that subsurface volatiles migrating into the building are completely mixed within the building volume, which is determined by the building area and mixing height. The building mixing height will depend on a number of factors including building height; heating, ventilation, and air conditioning (HVAC) system operation, environmental factors such as indoor-outdoor pressure differentials and wind loading, and seasonal factors. For a single-story house, the variation in mixing height can be approximated by using the room height. For a multi-story house or apartment building, the mixing height will be greatest for houses with HVAC systems that result in significant air circulation (e.g., forced-air heating systems). Mixing heights would likely be less for houses with electrical baseboard heaters. It is likely that mixing height is, to some degree, correlated to the building air exchange rate.

Little data are available that provides for direct inference of mixing height. There are few sites, with a small number of houses where indoor air concentrations were above background, and where both measurements at ground level and the second floor were made Colorado Department of Transportation (CDOT), Redfields, Eau Claire). Persons familiar with the data sets for these sites indicate that in most cases a fairly significant reduction in concentrations (factor of two or greater) was observed, although at one site (Eau Claire, “S” residence), the indoor trichloroethylene (TCE) concentrations were similar in both the basement and second floor of the house. For the CDOT site apartments, there was an approximate five-fold reduction between the concentrations measured for the first floor and second floor units (Mr. Jeff Kurtz, EMSI, personal communication, June 2002). Less mixing would be expected for an apartment because there are less cross-floor connections than for a house. The value chosen for a basement house scenario (3.66 m) would be representative of a two-fold reduction or attenuation in vapor concentrations between floors.

Q_{soil} (Default Value = 5 L/min)

The method often used with the J&E Model for estimating the soil gas advection rate (Q_{soil}) through the building envelope is an analytical solution for two-dimensional soil gas flow to a small horizontal drain (Nazaroff 1992) (“Perimeter Crack Model”). Use of this model can be problematic in that Q_{soil} values are sensitive to soil-air permeability and consequently a wide range in flows can be predicted.

An alternate empirical approach is to select a Q_{soil} value on the basis of tracer tests (i.e., mass balance approach). When soil gas advection is the primary mechanism for tracer intrusion into a building, the Q_{soil} can be estimated by measuring the concentrations of a chemical tracer in indoor air, in outdoor air, and in soil vapor below a building, and by measuring the building ventilation rate (Hers et al. 2000a; Fischer et al. 1996; Garbesi et al. 1993; Rezvan et al. 1991; Garbesi and Sextro, 1989). For sites with coarse-grained soils (Table 10). The Q_{soil} values measured using this technique are compared to predicted rates using the Perimeter Crack model. The Perimeter Crack model predictions are both higher and lower than the measured values, but overall are within one order of magnitude of the measured values. Although the Q_{soil} values predicted by the models and measured

using field tracer tests are uncertain, the results suggest that a “typical” range for houses on coarse-grained soils is on the order of 1 to 10 L/min. A disadvantage with the tracer test approach is that only limited data are available and there do not appear to be any tracer studies for field sites with fine-grained soils.

It is also important to recognize that the advective zone of influence for soil gas flow is limited to soil immediately adjacent to the building foundation. Some data on pressure coupling provide insight on the extent of the advective flow zone. For example, Garbesi *et al.* (1993) report a pressure coupling between the soil and experimental basement (*i.e.*, relative to that between the basement and atmosphere) equal to 96 percent directly below the slab, between 29 percent and 44 percent at 1 m below the basement floor slab, and between 0.7 percent and 27 percent at a horizontal distance of 2 m from the basement wall. At the Chatterton site (research site investigated by the author), the pressure coupling immediately below the building floor slab ranged from 90 to 95 percent and at a depth of 0.5 m was on the order of 50 percent. These results indicate that the advective zone of influence will likely be limited to a zone within 1 to 2 m of the building foundation.

Because the advective flow zone is relatively limited in extent, the soil type adjacent to the building foundation is of importance. In many cases, coarse-grained imported fill is placed below foundations, and either coarse-grained fill, or disturbed, loose fill is placed adjacent to the foundation walls. Therefore, a conservative approach for the purposes of this guidance is to assume that soil gas flow will be controlled by coarse-grained soil, and not rely on the possible reduction in flow that would be caused by fine-grained soils near to the house foundation. For these reasons, a soil gas flow rate of 5 L/min (midpoint between 1 and 10 L/min) was chosen as the input value.

3.3 RUNNING THE MODELS

Eight different models are provided in MICROSOFT EXCEL formats.

1. Models for Soil Contamination:
SL-SCREEN-Feb 04.XLS
SL-ADV-Feb 04.XLS
2. Models for Groundwater Contamination:
GW-SCREEN-Feb 04.XLS
GW-ADV-Feb 04.XLS
3. Model for Soil Gas Contamination
SG-SCREEN-Feb 04.xls
SG-ADV-Feb 04.xls
4. Models for Non Aqueous Phase Liquids
NAPL-SCREEN-Feb 04.xls

Both the screening-level models and the advanced models allow the user to calculate a risk-based media concentration or incremental risks from an actual starting concentration in soil or in groundwater. Data entry within the screening-level models is limited to the most sensitive model parameters and incorporates only one soil stratum above the contamination. The advanced models provide the user with the ability to enter data for all of the model parameters and also incorporate up to three individual soil strata above the contamination for which soil properties may be varied.

To run any of the models, simply open the appropriate model file within MICROSOFT EXCEL. Each model is constructed of the following worksheets:

1. DATENTER (Data Entry Sheet)
2. CHEMPROPS (Chemical Properties Sheet)
3. INTERCALCS (Intermediate Calculations Sheet)
4. RESULTS (Results Sheet)
5. VLOOKUP (Lookup Tables).

The following is an explanation of what is contained in each worksheet, how to enter data, how to interpret model results, and how to add/revise the chemical properties data found in the VLOOKUP Tables. As examples, Appendix C contains all the worksheets for the advanced soil contamination model SL-ADV.

3.4 THE DATA ENTRY SHEET (DATENTER)

Figure 4 is an example of a data entry sheet. In this case, it shows the data entry sheet for the screening-level model for contaminated groundwater (GW-SCREEN). Figure 5 is an example of an advanced model data entry sheet (GW-ADV). Note that the screening-level model sheet requires entry of considerably less data than does the advanced sheet. To enter data, simply position the cursor within the appropriate box and type the value; all other cells are protected.

Error Messages

In the case of the screening-level models, all error messages will appear in red type below the applicable row of data entry boxes. For the advanced models, error messages may appear on the data entry sheet or in the lower portion of the results sheet. Error messages will occur if required entry data are missing or if data are out of range or do not conform to model conventions. The error message will tell the user what kind of error has occurred.

GW-SCREEN
Version 3.1; 02/04

Reset to
Defaults

CALCULATE RISK-BASED GROUNDWATER CONCENTRATION (enter "X" in "YES" box)

YES X
OR

CALCULATE INCREMENTAL RISKS FROM ACTUAL GROUNDWATER CONCENTRATION
(enter "X" in "YES" box and initial groundwater conc. below)

YES

ENTER Chemical CAS No. (numbers only, no dashes)	ENTER Initial groundwater conc., C_w ($\mu\text{g/L}$)	Chemical
56235		Carbon tetrachloride

MORE
↓

ENTER Depth below grade to bottom of enclosed space floor, L_f (cm)	ENTER Depth below grade to water table, L_{WT} (cm)	ENTER SCS soil type directly above water table	ENTER Average soil/ groundwater temperature, T_s ($^{\circ}\text{C}$)	ENTER Average vapor flow rate into bldg. (Leave blank to calculate) Q_{soil} (L/m)
200	400	SC	10	5

MORE
↓

ENTER Vadose zone SCS soil type (used to estimate soil vapor permeability)	OR	ENTER User-defined vadose zone soil vapor permeability, k_v (cm^2)	ENTER Vadose zone SCS soil type Lookup Soil Parameters	ENTER Vadose zone soil dry bulk density, ρ_b^v (g/cm^3)	ENTER Vadose zone soil total porosity, n^v (unitless)	ENTER Vadose zone soil water-filled porosity, θ_w^v (cm^3/cm^3)
SC			SC	1.63	0.385	0.197

MORE
↓

ENTER Target risk for carcinogens, TR (unitless)	ENTER Target hazard quotient for noncarcinogens, THQ (unitless)	ENTER Averaging time for carcinogens, AT_C (yrs)	ENTER Averaging time for noncarcinogens, AT_{NC} (yrs)	ENTER Exposure duration, ED (yrs)	ENTER Exposure frequency, EF (days/yr)
1.0E-06	1	70	30	30	350
Used to calculate risk-based groundwater concentration.					

Figure 4. GW-SCREEN Data Entry Sheet

GW-ADV Version 3.1: 02/04
Reset to Defaults

CALCULATE RISK-BASED GROUNDWATER CONCENTRATION (enter "X" in "YES" box)

YES OR

CALCULATE INCREMENTAL RISKS FROM ACTUAL GROUNDWATER CONCENTRATION (enter "X" in "YES" box and initial groundwater conc. below)

YES

ENTER Initial groundwater conc., C_w ($\mu\text{g/L}$)

56235

Chemical
Carbon tetrachloride

ENTER	ENTER	ENTER	ENTER	ENTER	ENTER	ENTER	ENTER	ENTER	ENTER	ENTER	ENTER	ENTER	ENTER	ENTER	ENTER	ENTER	ENTER	ENTER	ENTER	ENTER	ENTER	ENTER	ENTER	ENTER	
Average soil/groundwater temperature, T_s ($^{\circ}\text{C}$)	Depth below grade to bottom of enclosed space floor, L_d (cm)	Thickness of soil stratum A, h_a (cm)	Thickness of soil stratum B, h_b (cm)	Thickness of soil stratum C, h_c (cm)	Soil stratum directly above water table, (Enter A, B, or C)	Soil stratum directly above water table, (Enter A, B, or C)	Soil stratum directly above water table	Soil stratum directly above water table	Soil stratum directly above water table	Soil stratum directly above water table	Soil stratum directly above water table	Soil stratum directly above water table	Soil stratum directly above water table	Soil stratum directly above water table	Soil stratum directly above water table	Soil stratum directly above water table	Soil stratum directly above water table	Soil stratum directly above water table	Soil stratum directly above water table	Soil stratum directly above water table	Soil stratum directly above water table	Soil stratum directly above water table	Soil stratum directly above water table	Soil stratum directly above water table	Soil stratum directly above water table
10	200	300	50	50	C	C	SC	SC	C	C	C	C	C	C	C	C	C	C	C	C	C	C	C	C	C
ENTER Stratum A soil type	ENTER Stratum A soil dry bulk density, $\rho_{s,A}$ (g/cm^3)	ENTER Stratum A soil water-filled porosity, n^A (unitless)	ENTER Stratum A soil total porosity, n^A (unitless)	ENTER Stratum A soil dry bulk density, $\rho_{s,A}$ (g/cm^3)	ENTER Stratum B soil dry bulk density, $\rho_{s,B}$ (g/cm^3)	ENTER Stratum B soil total porosity, n^B (unitless)	ENTER Stratum B soil water-filled porosity, n^B (unitless)	ENTER Stratum B soil dry bulk density, $\rho_{s,B}$ (g/cm^3)	ENTER Stratum B soil total porosity, n^B (unitless)	ENTER Stratum B soil water-filled porosity, n^B (unitless)	ENTER Stratum B soil dry bulk density, $\rho_{s,B}$ (g/cm^3)	ENTER Stratum B soil total porosity, n^B (unitless)	ENTER Stratum B soil water-filled porosity, n^B (unitless)	ENTER Stratum C soil dry bulk density, $\rho_{s,C}$ (g/cm^3)	ENTER Stratum C soil total porosity, n^C (unitless)	ENTER Stratum C soil water-filled porosity, n^C (unitless)	ENTER Stratum C soil dry bulk density, $\rho_{s,C}$ (g/cm^3)	ENTER Stratum C soil total porosity, n^C (unitless)	ENTER Stratum C soil water-filled porosity, n^C (unitless)	ENTER Stratum C soil dry bulk density, $\rho_{s,C}$ (g/cm^3)	ENTER Stratum C soil total porosity, n^C (unitless)	ENTER Stratum C soil water-filled porosity, n^C (unitless)	ENTER Stratum C soil dry bulk density, $\rho_{s,C}$ (g/cm^3)	ENTER Stratum C soil total porosity, n^C (unitless)	ENTER Stratum C soil water-filled porosity, n^C (unitless)
10	40	1000	388	0.1	0.25	0.375	0.054	1.83	0.385	1.83	0.385	1.83	0.385	1.83	0.385	1.83	0.385	1.83	0.385	1.83	0.385	1.83	0.385	1.83	0.385
ENTER Enclosed space thickness, L_{enc} (cm)	ENTER Enclosed space floor length, L_f (cm)	ENTER Enclosed space floor width, W_f (cm)	ENTER Enclosed space height, H_f (cm)	ENTER Floor-wall seam crack width, w (cm)	ENTER Indoor air exchange rate, ER (1/h)	ENTER Average vapor flow rate into bldg OR Leave blank to calculate Q_{soil} (L/m)	ENTER Target risk for carcinogens, TR (unitless)	ENTER Target risk for noncarcinogens, TR (unitless)	ENTER Target risk for carcinogens, TR (unitless)	ENTER Target risk for noncarcinogens, TR (unitless)	ENTER Target risk for carcinogens, TR (unitless)	ENTER Target risk for noncarcinogens, TR (unitless)	ENTER Target risk for carcinogens, TR (unitless)	ENTER Target risk for noncarcinogens, TR (unitless)	ENTER Target risk for carcinogens, TR (unitless)	ENTER Target risk for noncarcinogens, TR (unitless)	ENTER Target risk for carcinogens, TR (unitless)	ENTER Target risk for noncarcinogens, TR (unitless)	ENTER Target risk for carcinogens, TR (unitless)	ENTER Target risk for noncarcinogens, TR (unitless)	ENTER Target risk for carcinogens, TR (unitless)	ENTER Target risk for noncarcinogens, TR (unitless)	ENTER Target risk for carcinogens, TR (unitless)	ENTER Target risk for noncarcinogens, TR (unitless)	ENTER Target risk for carcinogens, TR (unitless)
10	40	1000	388	0.1	0.25	0.375	0.054	1.83	0.385	1.83	0.385	1.83	0.385	1.83	0.385	1.83	0.385	1.83	0.385	1.83	0.385	1.83	0.385	1.83	0.385
ENTER Averaging time for carcinogens, AT_c (yrs)	ENTER Averaging time for noncarcinogens, AT_{nc} (yrs)	ENTER Exposure duration, ED (yrs)	ENTER Exposure frequency, EF (days/yr)	ENTER Target risk for carcinogens, TR (unitless)	ENTER Target risk for noncarcinogens, TR (unitless)	ENTER Target risk for carcinogens, TR (unitless)	ENTER Target risk for noncarcinogens, TR (unitless)	ENTER Target risk for carcinogens, TR (unitless)	ENTER Target risk for noncarcinogens, TR (unitless)	ENTER Target risk for carcinogens, TR (unitless)	ENTER Target risk for noncarcinogens, TR (unitless)	ENTER Target risk for carcinogens, TR (unitless)	ENTER Target risk for noncarcinogens, TR (unitless)	ENTER Target risk for carcinogens, TR (unitless)	ENTER Target risk for noncarcinogens, TR (unitless)	ENTER Target risk for carcinogens, TR (unitless)	ENTER Target risk for noncarcinogens, TR (unitless)	ENTER Target risk for carcinogens, TR (unitless)	ENTER Target risk for noncarcinogens, TR (unitless)	ENTER Target risk for carcinogens, TR (unitless)	ENTER Target risk for noncarcinogens, TR (unitless)	ENTER Target risk for carcinogens, TR (unitless)	ENTER Target risk for noncarcinogens, TR (unitless)	ENTER Target risk for carcinogens, TR (unitless)	
70	30	30	350	1.0E-06	1	1.0E-06	1	1.0E-06	1	1.0E-06	1	1.0E-06	1	1.0E-06	1	1.0E-06	1	1.0E-06	1	1.0E-06	1	1.0E-06	1	1.0E-06	
70	30	30	350	1.0E-06	1	1.0E-06	1	1.0E-06	1	1.0E-06	1	1.0E-06	1	1.0E-06	1	1.0E-06	1	1.0E-06	1	1.0E-06	1	1.0E-06	1	1.0E-06	

Figure 5. GW-ADV Data Entry Sheet

Figure 6 is an example of an error message appearing on the data entry sheet. Figure 7 illustrates error messages appearing within the message and error summary section on the results sheet (advanced models only).

Entering Data

Each data entry sheet requires the user to input values for model variables. Data required for the soil contamination scenario will differ from that required for the groundwater contamination scenario. In addition, data required for the screening-level models will differ from that required for the advanced models.

Model Variables--

The following is a list of all data entry variables required for evaluating either a risk-based media concentration or the incremental risks due to actual contamination. A description for which model(s) the variable is appropriate is given in parenthesis after the name of the variable. In addition, notes on how the variable is used in the calculations and how to determine appropriate values of the variable are given below the variable name. A quick determination of which variables are required for a specific model can be made by reviewing the data entry sheet for the model chosen. Example data entry sheets for each model can be found in Appendix D.

1. *Calculate Risk-Based Concentration or Calculate Incremental Risks from Actual Concentration* (All Soil and Groundwater Models)

The model will calculate either a risk-based soil or groundwater concentration or incremental risks but cannot calculate both simultaneously. Enter an "X" in only one box.

2. *Chemical CAS No.* (All Models)

Enter the appropriate CAS number for the chemical you wish to evaluate; do not enter dashes. The CAS number entered must exactly match that of the chemical, or the error message "CAS No. not found" will appear in the "Chemical" box. Once the correct CAS number is entered, the name of the chemical will automatically appear in the "Chemical" box. A total of 108 chemicals and their associated properties are included with each model; see Section 3.7 for instructions on adding/revising chemicals.

GW-SCREEN
Version 3.1; 02/04

Reset to
Defaults

CALCULATE RISK-BASED GROUNDWATER CONCENTRATION (enter "X" in "YES" box)

YES

OR

CALCULATE INCREMENTAL RISKS FROM ACTUAL GROUNDWATER CONCENTRATION
(enter "X" in "YES" box and initial groundwater conc. below)

YES

ENTER Chemical CAS No. (numbers only, no dashes)	ENTER Initial groundwater conc., C_w ($\mu\text{g/L}$)	Cannot calculate risk-based concentration and incremental risk simultaneously.
56235		Carbon tetrachloride

Figure 6. Example Error Message on Data Entry Sheet

RISK-BASED SOIL CONCENTRATION CALCULATIONS:

INCREMENTAL RISK CALCULATIONS:

Indoor exposure soil conc., carcinogen ($\mu\text{g/kg}$)	Indoor exposure soil conc., noncarcinogen ($\mu\text{g/kg}$)	Risk-based indoor exposure soil conc., ($\mu\text{g/kg}$)	Soil saturation conc., C_{sat} ($\mu\text{g/kg}$)	Final indoor exposure soil conc., ($\mu\text{g/kg}$)	Incremental risk from vapor intrusion to indoor air, carcinogen (unitless)	Hazard quotient from vapor intrusion to indoor air, noncarcinogen (unitless)
NA	NA	NA	3.09E+05	NA	8.0E-08	7.9E-04

MESSAGE AND ERROR SUMMARY BELOW: (DO NOT USE RESULTS IF ERRORS ARE PRESENT)

SCROLL
DOWN
TO "END"

ERROR: Combined thickness of strata A + B + C must be = depth below grade to top of contamination.

Figure 7. Example Error Message on Results Sheet

3. *Initial Soil or Groundwater Concentration* (All Soil and Groundwater Models) (L_w)

Enter a value only if incremental risks are to be calculated. Be sure to enter the concentration in units of $\mu\text{g}/\text{kg}$ (wet weight basis soil) or $\mu\text{g}/\text{L}$ (groundwater). Typically, this value represents the average concentration within the zone of contamination. If descriptive statistics are not available to quantify the uncertainty in the average value, the maximum value may be used as an upper bound estimate.

4. *Average Soil/Groundwater Temperature* (All Models) (T_s)

The soil/groundwater temperature is used to correct the Henry's law constant to the specified temperature. Figure 8 from U.S. EPA (1995) shows the average temperature of shallow groundwater in the continental United States. Shallow groundwater temperatures may be used to approximate subsurface soil temperatures greater than 1 to 2 meters below the ground surface. Another source of information may be your State groundwater protection regulatory agency.

5. *Depth Below Grade to Bottom of Enclosed Space Floor* (All Models) (L_F)

Enter the depth to the bottom of the floor in contact with the soil. The default value for slab-on-grade and basement construction is 15 cm and 200 cm, respectively.

6. *Depth Below Grade to Top of Contamination* (Soil Models Only) (L_T)

Enter the depth to the top of soil contamination. If the contamination begins at the soil surface, enter the depth below grade to the bottom of the enclosed space floor. The depth to the top of contamination must be greater than or equal to the depth to the bottom of the floor.

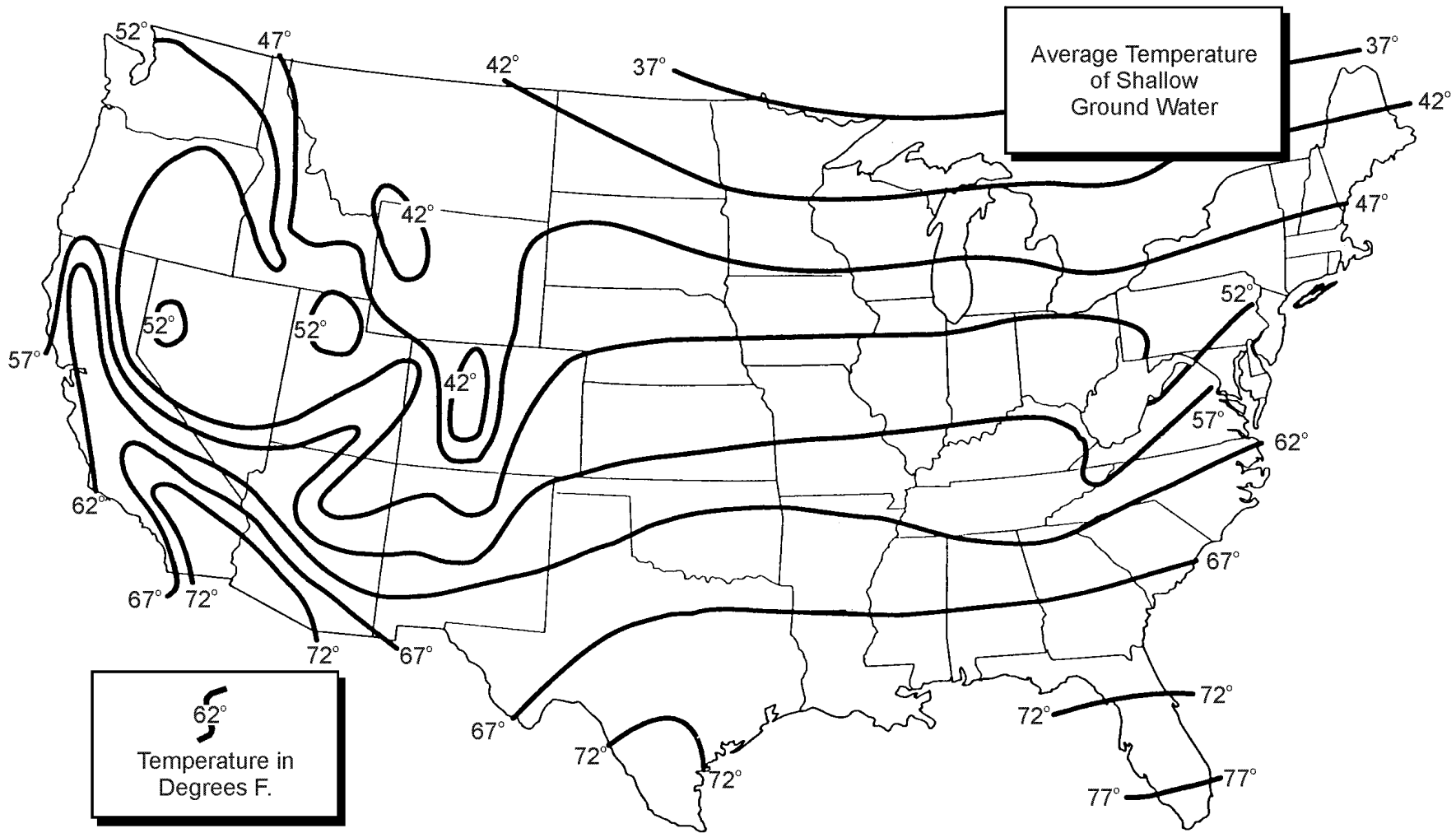

Figure 8. Average Shallow Groundwater Temperature in the United States

7. *Depth Below Grade to Water Table (Groundwater Models Only) (L_{wt})*

Enter the depth to the top of the water table (i.e., where the pressure head is equal to zero and the pressure is atmospheric).

Note: The thickness of the capillary zone is calculated based on the SCS soil textural classification above the top of the water table. The depth below grade to the top of the water table minus the thickness of the capillary zone must be greater than the depth below grade to the bottom of the enclosed space floor. This means that the top of the capillary zone is always below the floor.

8. *Depth Below Grade to Bottom of Contamination (Advanced Soil Model Only) (L_B)*

This value is used to calculate the thickness of soil contamination. A value greater than zero and greater than the depth to the top of contamination will automatically invoke the finite source model. If the thickness of contamination is unknown, two options are available:

1. Entering a value of zero will automatically invoke the infinite source model.
2. Enter the depth to the top of the water table. This will invoke the finite source model under the assumption that contamination extends from the top of contamination previously entered down to the top of the water table.

9. *Thickness of Soil Stratum "X" (Advanced Models Only) (h_x , $x = A, B, \text{ or } C$)*

In the advanced models, the user can define up to three soil strata between the soil surface and the top of contamination or to the soil gas sampling depth, as appropriate. These strata are listed as A, B, and C. Stratum A extends down from the soil surface, Stratum B is below Stratum A, and Stratum C is the deepest stratum. The thickness of Stratum A must be at least as thick as the depth below grade to the bottom of the enclosed space floor. The combined thickness of all strata must be equal to the depth to the top of contamination, or to the soil gas sampling depth, as appropriate. If soil strata B and/or C are not to be considered, a value of zero must be entered for each stratum not included in the analysis.

10. *Soil Stratum A SCS Soil Type (Advanced Models Only) (SES – soil)*

Enter one of the following SCS soil type abbreviations:

<u>Abbreviation</u>	<u>SCS Soil Type</u>
C	Clay
CL	Clay loam
L	Loam
LS	Loamy sand
S	Sand
SC	Sandy clay
SCL	Sandy clay loam
SI	Silt
SIC	Silty clay
SICL	Silty clay loam
SIL	Silty loam
SL	Sandy loam

The SCS soil textural classification can be determined by using either the ATSM Standard Test Method for Particle-Size Analysis of Soils (D422-63) or by using the analytical procedures found in the U.S. Natural Resources Conservation Service (NRCS) Soil Survey Laboratory Methods Manual, Soil Survey Laboratory Investigations Report No. 42. After determining the particle size distribution of a soil sample, the SCS soil textural classification can be determined using the SCS classification chart in Figure 7.

The SCS soil type along with the Stratum A soil water-filled porosity is used to estimate the soil vapor permeability of Stratum A which is in contact with the floor and walls of the enclosed space below grade. Alternatively, the user may define a soil vapor permeability (see Variable No. 11).

11. *User-Defined Stratum A Soil Vapor Permeability (Advanced Models Only)(K_v)*

As an alternative to estimating the soil vapor permeability of soil Stratum A, the user may define the soil vapor permeability. As a general guide, the following represent the practical range of vapor permeabilities:

<u>Soil type</u>	<u>Soil vapor permeability, cm²</u>
Medium sand	1.0 x 10 ⁻⁷ to 1.0 x 10 ⁻⁶
Fine sand	1.0 x 10 ⁻⁸ to 1.0 x 10 ⁻⁷
Silty sand	1.0 x 10 ⁻⁹ to 1.0 x 10 ⁻⁸
Clayey silts	1.0 x 10 ⁻¹⁰ to 1.0 x 10 ⁻⁹

12. *Vadose Zone SCS Soil Type (Screening Models Only) (SCS – soil)*

Because the screening-level models accommodate only one soil stratum above the top of contamination or soil gas sampling depth, enter the SCS soil type from the list given in Variable No. 10.

13. *User-Defined Vadose Zone Soil Vapor Permeability (Screening Models Only) (K_v)*

For the same reason cited in No. 12 above, the user may alternatively define a soil vapor permeability. Use the list of values given in Variable No. 11 as a general guide.

14. *Soil Stratum Directly Above the Water Table (Advanced Groundwater Models Only) (A, B, or C)*

Enter either A, B, or C as the soil stratum directly above the water table. This value must be the letter of the deepest stratum for which a thickness value has been specified under Variable No. 9.

15. *SCS Soil Type Directly Above Water Table (Groundwater Models Only) (SCS – soil)*

Enter the correct SCS soil type from the list given in Variable No. 10 for the soil type directly above the water table. The soil type entered is used to estimate the rise (thickness) of the capillary zone.

16. *Stratum "X" Soil Dry Bulk Density* (Advanced Models Only) (P_x , $x = A, B, \text{ or } C$)

Identify the soil type for each strata and accept the default value or enter a site-specific value for the average soil dry bulk density. Dry bulk density is used in a number of intermediate calculations and is normally determined by field measurements (ASTM D 2937 Method).

17. *Stratum "X" Soil Total Porosity* (Advanced Models Only) (n^x , $x = A, B, \text{ or } C$)

Total soil porosity (n) is determined as:

$$n = 1 - \rho_b / \rho_s$$

where ρ_b is the soil dry bulk density (g/cm^3) and ρ_s is the soil particle density (usually 2.65 g/cm^3).

18. *Stratum "X" Soil Water-Filled Porosity* (Advanced Models Only) (θ_w^x , $X = a, b, \text{ or } c$)

Enter the average long-term volumetric soil moisture content; this is typically a depth-averaged value for the appropriate soil stratum. A long-term average value is typically not readily available. Do not use values based on episodic measurements unless they are representative of long-term conditions. Table 10 provides a soil-specific range of typical value for specified soils. The user must define soil type or input site-specific values.

One option is to use a model to estimate the long-term average soil water-filled porosities of each soil stratum between the enclosed space floor and the top of contamination. The HYDRUS model version 5.0 (Vogel et al., 1996) is a public domain code for simulating one-dimensional water flow, solute transport, and heat movement in variably-saturated soils. The water flow simulation module of HYDRUS will generate soil water content as a function of depth and time given actual daily precipitation data. Model input requirements include either the soil hydraulic properties of van Genuchten (1980) or those of Brooks and Corey (1966). The van Genuchten soil hydraulic properties required are the same as those given in Tables 3 and 4 (i.e., θ_s , θ_r , N , α_1 , and K_s). The HYDRUS model is available from the U.S. Department of Agriculture (USDA) - Agricultural Research Service in Riverside, California via their internet website at <http://www.ussl.ars.usda.gov/MODELS/HYDRUS.HTM>. One and two-dimensional commercial versions of HYDRUS (Windows versions) are available at the International Ground Water Modeling Center website at <http://www.mines.edu/research/igwmc/software/>. Schaap and Leij (1998) have recently developed a Windows program entitled ROSETTA for estimating the van Genuchten soil hydraulic properties based on a limited or more extended set of input

data. The ROSETTA program can be found at the USDA website: <http://www.ussl.ars.usda.gov/MODELS/rosetta/rosetta.htm>. The van Genuchten hydraulic properties can then be input into HYDRUS to estimate soil moisture content.

19. *Stratum "X" Soil Organic Carbon Fraction* (Advanced Soil Models Only) (f_{oc}^X , X = A, B, or c)

Enter the depth-averaged soil organic carbon fraction for the stratum specified. Soil organic carbon is measured by burning off soil carbon in a controlled-temperature oven. This parameter, along with the chemical's organic carbon partition coefficient (K_{oc}), is used to determine the soil-water partition coefficient (K_d).

20. *Vadose Zone Soil Dry Bulk Density* (Screening Models Only) (ρ^A)

Because the screening-level models accommodate only one soil stratum above the top of contamination, identify the soil type and accept the default values or enter the depth-averaged soil dry bulk density. The universal default value is 1.5 g/cm³, which is consistent with U.S. EPA (1996a and b) for subsurface soils.

21. *Vadose Zone Soil Total Porosity* (Screening Models Only) (m^A)

Because the screening-level models accommodate only one soil stratum above the top of contamination, enter the depth-averaged soil total porosity. The default value is 0.43, which is consistent with U.S. EPA (1996a and b) for subsurface soils.

22. *Vadose Zone Soil Water-Filled Porosity* (Screening Models Only) (θ_w^A)

Because the screening-level models accommodate only one soil stratum above the top of contamination, enter the depth-averaged soil water-filled porosity. The default value is 0.30, which is consistent with U.S. EPA (1996a and b) for subsurface soils.

23. *Vadose Zone Soil Organic Carbon Fraction* (Soil Screening Model Only) (f_{oc}^A)

Because the screening-level models accommodate only one soil stratum above the top of contamination, enter the depth-averaged soil organic carbon fraction. The default value is 0.002, which is consistent with U.S. EPA (1996a and b) for subsurface soils.

24. *Enclosed Space Floor Thickness* (Advanced Models Only) (L_{crack})

Enter the thickness of the floor slab. All models operate under the assumption that the floor in contact with the underlying soil is composed of impermeable concrete

whether constructed as a basement floor or slab-on-grade. The default value is 10 cm, which is consistent with J&E (1991).

25. *Soil-Building Pressure Differential* (Advanced Models Only) (ΔP)

Because of wind effects on the structure, stack effects due to heating of the interior air, and unbalanced mechanical ventilation, a negative pressure with respect to the soil surface is generated within the structure. This pressure differential (ΔP) induces a flow of soil gas through the soil matrix and into the structure through cracks, gaps, and openings in the foundation. The effective range of values of ΔP is 0-20 pascals (Pa) (Loureiro et al., 1990; Eaton and Scott, 1984). Individual average values for wind effects and stack effects are approximately 2 Pa (Nazaroff et al., 1985; Put and Meijer, 1989). Typical values for the combined effects of wind pressures and heating are 4 to 5 Pa (Loureiro et al., 1990; Grimsrud et al., 1983). A conservative default value of ΔP was therefore chosen to be 4 Pa (40 g/cm-s²).

For more information on estimating site-specific values of ΔP , the user is referred to Nazaroff et al. (1987) and Grimsrud et al. (1983).

26. *Enclosed Space Floor Length* (Advanced Models Only) (L_B)

The default value is 1000 cm (see Variable No. 28).

27. *Enclosed Space Floor Width* (Advanced Models Only) (W_B)

The default value is 1000 cm (see Variable No. 28).

28. *Enclosed Space Height* (Advanced Models Only) (H_B)

For a single story home, the variation in mixing height will be the greatest for houses with HVAC systems that result in significant air circulation (e.g., forced air heat pump). Mixing heights would be less for houses with electrical baseboard heaters.

The mixing height is approximated by the room height. The default value is 2.44 meters for a single story house without a basement.

For a single story house with a basement less mixing would be expected because of the cross floor connections. The default values for a house with a basement is 3.66 m. This value represents a two-fold reduction in vapor concentrations between the floors.

29. *Floor-Wall Seam Crack Width* (Advanced Models Only) (W)

The conceptual model used in the spreadsheets follows that of Loureiro et al. (1990) and Nazaroff (1988) and is illustrated in Figure 9. The model is based on a single-

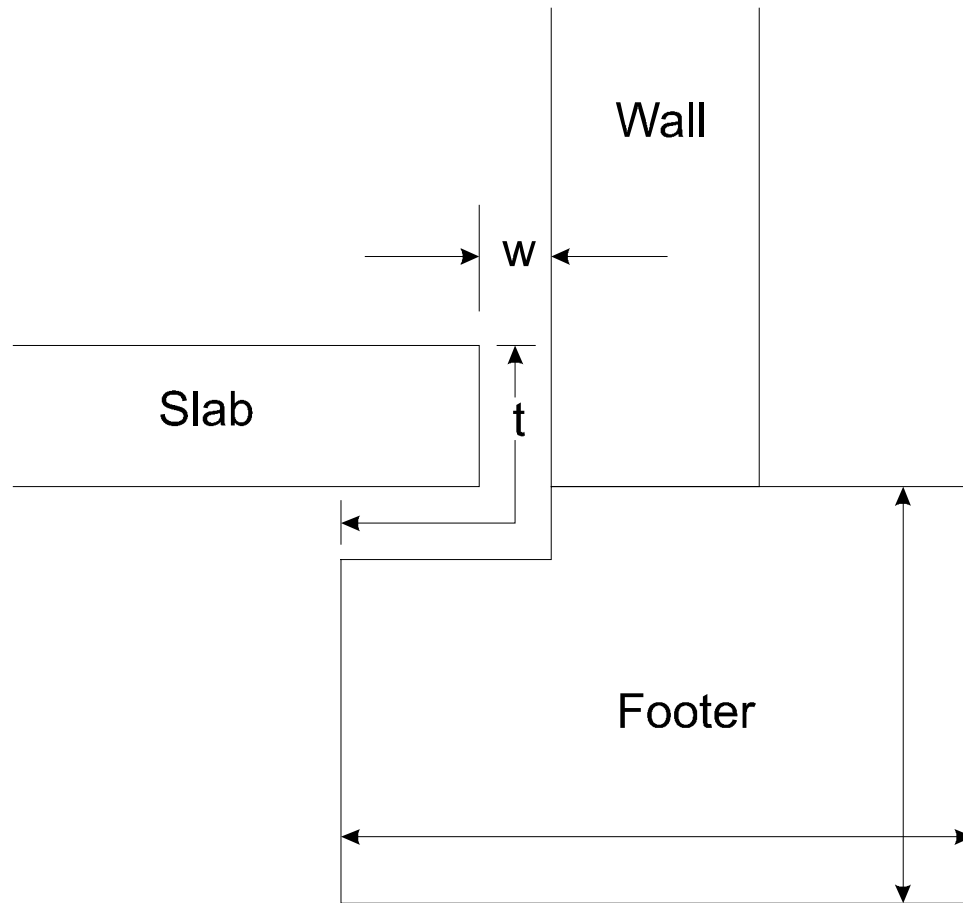

Figure 9. Floor Slab and Foundation

family house with a poured concrete basement floor and wall foundations, or constructed slab-on-grade in similar fashion. A gap is assumed to exist at the junction between the floor and the foundation along the perimeter of the floor. The gap exists as a result of building design or concrete shrinkage. This gap is assumed to be the only opening in the understructure of the house and therefore the only route for soil gas entry.

Eaton and Scott (1984) reported typical open areas of approximately 300 cm^2 for the joints between walls and floor slabs of residential structures in Canada. Therefore, given the default floor length and width of 1000 cm, a gap width (w) of 0.1 cm equates to a total gap area of 900 cm^2 , which is reasonable given the findings of Eaton and Scott. This value of the gap width is also consistent with the typical value reported in Loureiro et al. (1990). The default value of the floor-wall seam crack width was therefore set equal to 0.1 cm.

30. *Indoor Air Exchange Rate (Advanced Models Only) (ER)*

The indoor air exchange rate is used along with the building dimensions to calculate the building ventilation rate. The default value of the indoor air exchange rate is 0.25/h. This value is consistent with the 10th percentile of houses in all regions of the U.S., as reported in Koontz and Rector (1995). This value is also consistent with the range of the control group of 331 houses in a study conducted by Parker et al. (1990) to compare data with that of 292 houses with energy-efficient features in the Pacific Northwest.

31. *Averaging Time for Carcinogens (All Models) (AT_c)*

Enter the averaging time in units of years. The default value is 70 years.

32. *Averaging Time for Noncarcinogens (All Models) (AT_{nc})*

Enter the averaging time in units of years. The averaging time for noncarcinogens is set equal to the exposure duration. The default value for residential exposure from U.S. EPA (1996a and b) is 30 years.

33. *Exposure Duration (All Models) (ED)*

Enter the exposure duration in units of years. The default value for residential exposure from U.S. EPA (1996a and b) is 30 years.

34. *Exposure Frequency (All Models) (EF)*

Enter the exposure frequency in units of days/yr. The default value for residential exposure from U.S. EPA (1996a and b) is 350 days/yr.

35. *Target Risk for Carcinogens (All Soil and Groundwater Models) (TR)*

If a risk-based media concentration is to be calculated, enter the target risk-level. The default value is 1×10^{-6} .

36. *Target Hazard quotient for Noncarcinogens (All Soil and Groundwater Models) (THQ)*

If a risk-based media concentration is to be calculated, enter the target hazard quotient. The default value is 1.

The remaining four worksheets include the results sheet (RESULTS) and three ancillary sheets. The ancillary sheets include the chemical properties sheet (CHEMPROPS), the intermediate calculations sheet (INTERCALCS), and the lookup tables (VLOOKUP).

3.5 THE RESULTS SHEET (RESULTS)

Once all data are entered in the data entry sheet, the model results may be viewed on the RESULTS sheet. For the soil and groundwater models, calculations are presented as either a risk-based soil or groundwater concentration, or the incremental risks associated with an initial soil or groundwater concentration. In the case of the advanced models, the user should check the message and error summary below the results section to ensure that no error messages appear. If one or more error messages appear, re-enter the appropriate data.

The RESULTS worksheet shows the indoor exposure soil or groundwater concentration for either a carcinogen or noncarcinogen as appropriate. When a contaminant is both a carcinogen and a noncarcinogen, the risk-based indoor exposure concentration is set equal to the lower of these two values. In addition, the soil saturation concentration (C_{sat}) or the aqueous solubility limit (S) is also displayed for the soil and groundwater models, respectively.

The equilibrium vapor concentration at the source of contamination is limited by the value of C_{sat} for soil contamination and by the value of S for groundwater contamination, as appropriate. For a single contaminant, the vapor concentration directly above the source of soil contamination cannot be greater than that associated with the soil saturation concentration; for groundwater contamination, the vapor concentration cannot be greater than that associated with the solubility limit. As a result, subsurface soil concentrations greater than C_{sat} and groundwater concentrations greater than S will not produce higher vapor concentrations. Therefore, if the indoor vapor concentration predicted from a soil concentration greater than or equal to the value of C_{sat} and it does not exceed the health-based limit in indoor air (target risk or target hazard quotient), the vapor intrusion pathway will not be of concern for that particular chemical. The same is true for an indoor vapor concentration predicted from a groundwater concentration greater than or equal to the value of S. That does not necessarily mean, however, that the subsurface contamination will not be of concern from a groundwater protection standpoint, (ingestion) and the potential for free-phase contamination (e.g., NAPL) must also be addressed.

For subsurface soils, the physical state of a contaminant at the soil temperature plays a significant role. When a contaminant is a liquid (or gas) at the soil temperature, the upper limit of the soil screening level is set at C_{sat} . This tends to reduce the potential for NAPL to exist within the vadose zone. The case is different for a subsurface contaminant that is a solid at the soil temperature. In this case, the screening level is not limited by C_{sat} because of the reduced possibility of leaching to the water table. If the model estimates a risk-based screening level greater than C_{sat} for a solid in soils, the model will display the final soil concentration as "NOC" or Not of Concern for the vapor intrusion pathway.

In the case of groundwater contamination, the physical state of the contaminant is not an issue in that the contamination has already reached the water table. Because the equilibrium vapor concentration at the source of emissions cannot be higher than that associated with the solubility limit, the vapor concentration is calculated at the solubility limit if the user enters a groundwater concentration greater than the value of S when forward-calculating risk. When reverse-calculating a risk-based groundwater concentration, the model will display the final groundwater concentration as "NOC" for the vapor intrusion pathway if the model calculates a risk-based level greater than or equal to the value of S. It should be noted, however, that if the soil properties or other conditions specified in the DATENTER worksheet are changed, the final risk-based soil or groundwater concentration must be remodeled.

It should also be understood that if a contaminant is labeled "Not of Concern" for the vapor intrusion pathway, all other relevant exposure pathways must be considered for both contaminated soils and groundwater.

3.6 THE CHEMICAL PROPERTIES SHEET (CHEMPROPS)

The chemical properties sheet provides a summary of the chemical and toxicological properties of the chemical selected for analysis. These data are retrieved from the VLOOKUP sheet by CAS number. All data in the chemical properties sheet are protected.

3.7 THE INTERMEDIATE CALCULATIONS SHEET (INTERCAL)

The intermediate calculations sheet provides solutions to intermediate variables. Review of the values of the intermediate variables may be helpful in an analysis of the cause-and-effect relationships between input values and model results. All data in the intermediate calculations sheet are protected.

3.8 THE LOOKUP TABLES (VLOOKUP)

The VLOOKUP sheet contains two lookup tables from which individual data are retrieved for a number of model calculations. The first table is the Soil Properties Lookup Table. This table contains the average soil water retention curve data of Hers (2002) and Schaap and Leij (1998) and the mean grain diameter data of Nielson and Rogers (1990) by SCS soil type, and the mean dry bulk density from Leij, Stevens, et al (1994).

3.9 ADDING, DELETING, OR REVISING CHEMICALS

Data for any chemical may be edited, new chemicals added, or existing chemicals deleted from the Chemical Properties Lookup Table within the VLOOKUP worksheet. To begin an editing

session, the user must unprotect (unseal) the worksheet (the password is "ABC" in capital letters); editing of individual elements or addition and deletion of chemicals may then proceed. Space has been allocated for up to 260 chemicals in the lookup table. Row number 284 is the last row that may be used to add new chemicals. After the editing session is complete, the user must sort all the data in the lookup table (except the column headers) in ascending order by CAS number. After sorting is complete, the worksheet should again be protected (sealed).

SECTION 4

SOIL GAS MODEL APPLICATION

Two additional models have been added to allow the user to input measured soil gas concentration and sampling depth data directly into the spreadsheet. These models eliminate the need for theoretical partitioning of a total volume soil concentration or a groundwater concentration into discrete phases. This section provides instructions for using the soil gas models.

4.1 RUNNING THE MODELS

Two models are provided as MICROSOFT EXCEL spreadsheets. The screening-level model is titled SG-SCREEN.xls (EXCEL). The advanced model is titled SG-ADV.xls.

Both the screening-level and advanced models allow the user to calculate steady-state indoor air concentrations and incremental risks from user-defined soil gas concentration data. The models do not allow for reverse-calculation of a risk-based soil or groundwater concentration. As with the soil and groundwater screening-level models, the SG-SCREEN model operates under the assumption that the soil column properties are homogeneous and isotropic from the soil surface to an infinite depth. In addition, the SG-SCREEN model uses the same default values for the building properties as the SL-SCREEN and GW-SCREEN models. The advanced model allows the user to specify up to three different soil strata from the bottom of the building floor in contact with the soil to the soil gas sampling depth. Finally, the advanced model allows the user to specify values for all of the model variables.

To run the models, simply open the appropriate file within either MICROSOFT EXCEL worksheet. Each model is constructed of the following worksheets:

1. DATENTER (Data Entry Sheet)
2. CHEMPROPS (Chemical Properties Sheet)
3. INTERCALCS (Intermediate Calculations Sheet)
4. RESULTS (Results Sheet)
5. VLOOKUP (Lookup Tables)

Each worksheet follows the form of the worksheets in the soil and groundwater models. See Section 4.2 for a description of each worksheet.

The DATENTER worksheet of each of the soil gas models is different than those of the soil and groundwater models. Figure 10 shows the DATA ENTER worksheet of the SG-ADV model. Note that there is no option for running the model to calculate a risk-based media concentration. As with the other models, the user enters the CAS number of the chemical of interest. This automatically retrieves the chemical and toxicological data for that chemical. The CAS number must match one of the chemicals listed in the VLOOKUP worksheet, or the message "CAS No. not found" will appear in the "Chemical" box. The user also has the opportunity to add new chemicals to the data base. Next, the user must enter a value for the soil gas concentration of the chemical of interest. The user may enter this value in units of $\mu\text{g}/\text{m}^3$ or parts-per-million by volume (ppmv). If the soil gas concentration is entered in units of ppmv, the concentration is converted to units of $\mu\text{g}/\text{m}^3$ by:

$$C_g' = \frac{C_g \times MW}{R \times T_S} \quad (33)$$

where

- C_g' = Soil gas concentration, $\mu\text{g}/\text{m}^3$
- C_g = Soil gas concentration, ppmv
- MW = Molecular weight, g/mol
- R = Gas constant (= 8.205 E-05 atm- $\text{m}^3/\text{mol} \cdot ^\circ\text{K}$)
- T_S = System (soil) temperature, $^\circ\text{K}$.

In the soil gas models, the steady-state indoor air concentration is calculated by Equation 19 (i.e., $C_{\text{building}} = \alpha C_{\text{source}}$). The value of the vapor concentration at the source of emissions (C_{source}) is assigned the value of the user-defined soil gas concentration. The value of the steady-state attenuation coefficient (α) in Equation 19 is calculated by Equation 13. Because no evaluation has been made of the extent of the source of emissions, steady-state conditions (i.e., a non-diminishing source) must be assumed.

The SG-SCREEN model operates under the assumption of homogeneously distributed soil properties and isotropic conditions with respect to soil vapor permeability from the soil surface to an infinite depth. The SG-ADV model, on the other hand, allows the user to specify up to three different soil strata between the building floor in contact with the soil and the soil gas sampling depth. Soil properties within these three strata may be varied to allow for different diffusion resistances to vapor transport.

4.2 SOIL GAS SAMPLING

In order to use the soil gas models, soil gas concentrations must be measured at one or more depths below ground surface (bgs). The user is advised to take samples directly under building slabs

SG-ADV
Version 3.1: 02/04

Reset to Defaults

Soil Gas Concentration Data

ENTER Chemical CAS No. (numbers only, no dashes)	ENTER Soil gas conc., C_g ($\mu\text{g}/\text{m}^3$)	OR	ENTER Soil gas conc., C_g (ppmv)
71432			2.00E+01
Chemical Benzene			

MORE
↓

ENTER Depth below grade to bottom of enclosed space floor, L_f (cm)	ENTER Soil gas sampling depth below grade, L_s (cm)	ENTER Average soil temperature, T_s (°C)	ENTER Thickness of soil stratum A, h_a (cm)	ENTER Thickness of soil stratum B, h_b (cm)	ENTER Thickness of soil stratum C, h_c (Enter value or 0)	ENTER Soil stratum A SCS soil type used to estimate soil vapor permeability	ENTER User-defined stratum A soil vapor permeability, k_a (cm^2)
200	400	10	200	100	100	L	

MORE
↓

ENTER Stratum A SCS soil type parameters	ENTER Stratum A soil total porosity, n^a (unitless)	ENTER Stratum A soil dry bulk density, ρ_b^a (g/cm^3)	ENTER Stratum A soil water-filled porosity, θ_w^a (cm^3/cm^3)	ENTER Stratum B SCS soil type parameters	ENTER Stratum B soil dry bulk density, ρ_b^b (g/cm^3)	ENTER Stratum B soil total porosity, n^b (unitless)	ENTER Stratum B soil water-filled porosity, θ_w^b (cm^3/cm^3)	ENTER Stratum C SCS soil type parameters	ENTER Stratum C soil dry bulk density, ρ_b^c (g/cm^3)	ENTER Stratum C soil total porosity, n^c (unitless)	ENTER Stratum C soil water-filled porosity, θ_w^c (cm^3/cm^3)
	1.5	1.5	0.15		1.5	0.43	0.25		1.7	0.38	0.3

MORE
↓

ENTER Enclosed space floor thickness, L_{enc} (cm)	ENTER Soil-bldg pressure differential, ΔP (g/cm^2)	ENTER Enclosed space floor length, L_e (cm)	ENTER Enclosed space width, W_e (cm)	ENTER Enclosed space height, H_b (cm)	ENTER Floor-wall seam crack width, w (cm)	ENTER Indoor air exchange rate, ER, (1/h)	ENTER Average vapor flow rate into bldg, OR Leave blank to calculate Q_{air} (L/m^3)
10	40	1000	1000	366	0.1	0.25	5

END

ENTER Averaging time for carcinogens, AT_c (yrs)	ENTER Averaging time for noncarcinogens, AT_{nc} (yrs)	ENTER Exposure duration, ED (yrs)	ENTER Exposure frequency, EF (days/yr)
70	30	30	350

Figure 10. SG-ADV Data Entry Worksheet

or basement floors when possible. This can be accomplished by drilling through the floor and sampling through the drilled hole. Alternatively, an angle-boring rig can be used to sample beneath the floor from outside the footprint of the building. When sampling directly beneath the floor is not possible, enough samples adjacent to the structure should be taken to adequately estimate an average concentration based on reasonable spatial and temporal scales.

Soil gas measurements can be made using several techniques; however, active whole-air sampling methods and active or passive sorbent sampling methods are usually employed. Typically, a whole-air sampling method is used whereby a non-reactive sampling probe is inserted into the soil to a prescribed depth. This can be accomplished manually using a "slam bar," or a percussion power drill, or the probe can be inserted into the ground using a device such as a Geoprobe.[®] The Geoprobe[®] device is attached to the rear of a specially customized vehicle. In the field, the rear of the vehicle is placed over the sample location and hydraulically raised on its base. The weight of the vehicle is then used to push the sampling probe into the soil. A built-in hammer mechanism allows the probe to be driven to predetermined depths up to 50 feet depending on the type of soil encountered. Soil gas samples can be withdrawn directly from the probe rods, or flexible tubing can be connected to the probe tips at depth for sample withdrawal.

Whole-air sampling is typically accomplished using an evacuated Summa or equivalent canister, or by evacuation to a Tedlar bag. Normal operation includes the use of an in-line flow controller and a sintered stainless steel filter to minimize particles becoming entrained in the sample atmosphere. For a 6-liter Summa canister, a normal sampling flow rate for a 24-hr integrated sample might be on the order of 1.5 ml/min; however, higher sampling rates can be used for grab samples. The sampling rate chosen, however, must not be so high as to allow for ambient air leakage between the annulus of the probe and the surrounding soils. Depending on the target compounds, excessive air leakage can dilute the sample (in some cases below the analytical detection limits).

One way to check for leakage is to test an aliquot of the sample gas for either nitrogen or oxygen content before the sample is routed to the canister or Tedlar bag. To test for nitrogen in real- or near real-time requires a portable gas chromatograph/mass spectrometer (GC/MS). A portable oxygen meter, however, can be used to test for sample oxygen content in real-time with a typical accuracy of one-half of one percent. If air leakage is detected by the presence of excessive nitrogen or oxygen, the seal around the sample probe at the soil surface as well as all sampling equipment connections and fittings should be checked. Finally, the flow rate may need to be reduced to decrease or eliminate the air leakage.

The collection and concentration of soil gas contaminants can be greatly affected by the components of the sampling system. It is imperative to use materials that are inert to the contaminants of concern. Areas of sample collection that need particular attention are:

- The seal at the soil surface around the sample probe
- Use of a probe constructed of stainless steel or other inert material
- Minimization of the use of porous or synthetic materials (i.e., PTFE, rubber, or most plastics) that may adsorb soil gas and cause cross-contamination

- Purging of the sample probe and collection system before sampling
- Leak-check of sampling equipment to reduce air infiltration
- Keeping the length of all sample transfer lines as short as possible to minimize condensation of extracted gas in the lines.

The choice of analytical methods for whole-air soil gas sampling depends on the contaminants of concern. Concentrations of volatile organic compounds (VOCs) in the soil gas are typically determined using EPA Method TO-14 or TO-15. In the case of semi-volatile compounds, an active sorbent sampling methodology can be used. In this case, a low-volume sampling pump is normally used to withdraw the soil gas, which is then routed to a polyurethane foam (PUF) plug. Vapor concentrations of semi-volatile contaminants sorbed to the PUF are then determined using EPA Method TO-10. The active soil gas sampling equipment can be assembled to allow for both canister sampling for volatiles and PUF sampling for semi-volatiles.

Passive sorbent sampling involves burial of solid sorbent sampling devices called cartridges or cassettes to a depth of normally 5 feet or less. The cassettes may be configured with one or more sorbents depending on the list of target analytes, and are typically left in-ground for 72 to 120 hours or longer. During this time period, the vapor-phase soil gas contaminants pass through the cassette and are adsorbed as the soil gas moves toward the soil surface by diffusion and/or convection. Analytical methods for sorbent sampling depend on the target analytes and the sorbent used and may include EPA Method TO-10 or a modified EPA Method TO-1. Vapor-phase concentrations for some solid sorbent sampling systems are determined using the total mass of each contaminant recovered, the time in-ground, the cross-sectional area of the cassette, the diffusivity of the compound in air, and a quasi-empirical adsorption rate constant.

Recent EPA technology verification reports produced by the EPA National Exposure Research Laboratory (EPA 1998, 1998a) concluded, at least for two such systems, that the sorbent methodologies accurately accounted for the presence of most of the soil gas contaminants in the studies. Further, the reports concluded that the sorbent systems showed detection of contaminants at low concentrations not reported using an active whole-air sampling system. For one system, however, it was noted that as the vapor concentrations reported for the whole-air sampling system increased by 1 to 4 orders-of-magnitude, the associated concentrations reported for the sorbent system increased only marginally. Perhaps the best use of such passive sorbent sampling methods is to help confirm which contaminants are present in the soil gas and not necessarily contaminant concentrations.

An excellent discussion of soil gas measurement methods and limitations can be found in the ASTM Standard Guide for Soil Gas Monitoring in the Vadose Zone D5314-92e1. ASTM Standard Guides are available from the ASTM website at:

<http://www.astm.org>.

In addition, soil gas measurement method summaries can be found in the EPA Standard Operating Procedures for Soil Gas Sampling (SOP No. 2042) developed by the EPA Environmental Response

Team (ERT) in Edison, New Jersey. This document can be downloaded from the ERT Compendium of Standard Operating Procedures at the following website:

http://www.ert.org/media_resrcs/media_resrcs.asp.

Data Quality and Data Quality Objectives

The results of soil gas sampling must meet the applicable requirements for data quality and satisfy the data quality objectives of the study for which they are intended. Data quality objectives are qualitative and quantitative statements derived from the data quality objectives process that clarify study objectives, define the appropriate type of data, and specify the tolerable levels of potential decision errors that will be used to support site decisions. Data quality objectives are formulated in the first phase of a sampling project.

In the second phase of the project, a Quality Assurance Project Plan (QAPP) translates these requirements into measurement performance specifications and quality assurance/quality control procedures to provide the data necessary to satisfy the user's needs. The QAPP is the critical planning document for any environmental data collection operation because it documents how quality assurance and quality control activities will be implemented during the life of the project. Development of the data quality objectives and the QAPP for soil gas sampling should follow the guidance provided by EPA's Quality Assurance Division of the Office of Research and Development. Guidance documents concerning the development and integration of the data quality objectives and the QAPP can be obtained from the EPA website at:

http://epa.gov/ncercqa/qa/qa_docs.html.

In addition to the above guidance, the EPA Regional Office and/or other appropriate regulatory agency should be consulted concerning specific sampling requirements.

4.3 ASSUMPTIONS AND LIMITATIONS OF THE SOIL GAS MODEL

As discussed previously, the soil gas models operate under the assumption of steady-state conditions. This means that enough time has passed for the vapor plume to have reached the building of interest directly above the source of contamination and that the vapor concentrations have reached their maximum values. Depending on the depth at which the soil gas is sampled, diffusion of the soil gas toward the building is a function of the soil properties between the building floor in contact with the soil and the sampling depth. Convection of the soil gas into the structure is a function of the building properties and the effective soil vapor permeability. Assumptions and limitations of the soil gas models are the same as those in Section 2.11 with the exception of the source vapor concentration that is determined empirically through soil gas sampling.

The user should also recognize the inherent limitations of soil gas sampling. First, the geologic variability of the subsurface may be considerable. This may be especially problematic for

shallow soil gas sampling because soil moisture content can vary widely as a function of precipitation events and surface runoff. The soil moisture content has an exponential effect on the rate of vapor diffusion. Transformation processes such as biodegradation can also occur in shallow subsurface soils. In some cases, only a relatively thin stratum of bioactive soil can greatly reduce the emission flux toward the soil surface. Finally, subsurface phase equilibria is a dynamic process resulting in varying vapor-phase concentrations over time at the same sampling location and depth. These factors can result in significant differences in measured soil gas concentrations over relatively small spatial and temporal scales.

For these reasons, the planning phase of the soil gas-sampling program should carefully consider the inherent uncertainties in site-specific sampling and analytical data. In the final analysis, the extent of soil gas sampling is a trade-off between sampling costs and the degree of certainty required in the soil gas concentration data.

SECTION 5

ASSUMPTIONS AND LIMITATIONS OF THE J&E MODEL

The J&E Model is a one-dimensional analytical solution to diffusive and convective transport of vapors into indoor spaces. The model is formulated as an attenuation factor that relates the vapor concentration in the indoor space to the vapor concentration at the source. It was developed for use as a screening level model and consequently is based on a number of simplifying assumptions regarding contaminant distribution and occurrence, subsurface characteristics, transport mechanisms, and building construction.

EPA is suggesting that the J&E Model be used at Resource Conservation and Recovery Act (RCRA) Corrective Action Sites, Comprehensive Environmental Response, Compensation, and Liability Act (CERCLA)/Superfund Sites, and voluntary cleanup sites. EPA is not recommending that the J&E Model be used for sites contaminated with petroleum products if the products were derived from Underground Storage Tanks. The J&E Model does not account for contaminant attenuation (biodegradation, hydrolysis, sorption, and oxidation/reduction). Attenuation is potentially a significant concern for these type of sites. EPA is recommending that investigators use OSWER Directive 9610.17: Use of Risk Based Decision-Making in UST Corrective Action Programs to evaluate these types of sites.

The J&E Model as implemented by EPA assumes homogeneous soil layers with isotropic properties that characterize the subsurface. The first tier spreadsheet versions allow only one layer; the advanced spreadsheet versions allow up to three layers. Sources of contaminants that can be modeled include dissolved, sorbed, or vapor sources where the concentrations are below the aqueous solubility limit, the soil saturation concentration, and/or the pure component vapor concentration. The contaminants are assumed to be homogeneously distributed at the source. All but one of the spreadsheets assumes an infinite source. The exception is the advanced model for a bulk soil source, which allows for a finite source. For the groundwater and bulk soil models, the vapor concentration at the source is calculated assuming equilibrium partitioning. Vapor from the source is assumed to diffuse directly upward (one-dimensional transport) through uncontaminated soil (including an uncontaminated capillary fringe if groundwater is the vapor source) to the base of a building foundation, where convection carries the vapor through cracks and openings in the foundation into the building. Both diffusive and convective transport processes are assumed to be at steady state. Neither sorption nor biodegradation is accounted for in the transport of vapor from the source to the base of the building.

The assumptions described above and in Table 12 suggest a number of conditions that preclude the use of the Non-NAPL Models as implemented by EPA. These conditions include:

TABLE 12. ASSUMPTIONS AND LIMITATIONS OF THE VAPOR INTRUSION MODEL

Assumption	Implication	Field Evaluation
Contaminant		
No contaminant free-liquid/precipitate phase present	J&E Model not representative of NAPL partitioning from source	NAPL or not at site—easier to evaluation for floating product or soil contamination sites. Most DNAPL sites with DNAPL below the water table defy easy characterization.
Contaminant is homogeneously distributed within the zone of contamination		
No contaminant sources or sinks in the building.	Indoor sources of contaminants and/or sorption of vapors on materials may confound interpretation of results.	Survey building for sources, assessment of sinks unlikely
Equilibrium partitioning at contaminant source.	Groundwater flow rates are low enough so that there are no mass transfer limitations at the source.	Not likely
Chemical or biological transformations are not significant (model will predict more intrusion)	Tendency to over predict vapor intrusion for degradable compounds	From literature
Subsurface Characteristics		
Soil is homogeneous within any horizontal plane	Stratigraphy can be described by horizontal layers (not tilted layers)	Observe pattern of layers and unconformities Note: In simplified J&E Model layering is not considered
All soil properties in any horizontal plane are homogeneous		
The top of the capillary fringe must be below the bottom of the building floor in contact with the soil.		
EPA version of JE Model assumes the capillary fringe is uncontaminated.		
Transport Mechanisms		
One-dimensional transport	Source is directly below building, stratigraphy does not influence flow direction, no effect of two- or three-dimensional flow patterns.	Observe location of source, observe stratigraphy, pipeline conduits, not likely to assess two- and three-dimensional pattern.
Two separate flow zones, one diffusive one convective.	No diffusion (dispersion) in the convective flow zone. Plug flow in convective zone	Not likely
Vapor-phase diffusion is the dominant mechanism for transporting contaminant vapors from contaminant sources located away from the foundation to the soil region near the foundation	Neglects atmospheric pressure variation effects, others?	Not likely

(continued)

Assumption	Implication	Field Evaluation
Straight-line gradient in diffusive flow zone.	Inaccuracy in flux estimate at match point between diffusive and convective sections of the model.	Not likely
Diffusion through soil moisture will be insignificant (except for compounds with very low Henry's Law Constant	Transport through air phase only. Good for volatiles. Only low volatility compounds would fail this and they are probably not the compounds of concern for vapor intrusion	From literature value of Henry's Law Constant.
Convective transport is likely to be most significant in the region very close to a basement, or a foundation, and vapor velocities decrease rapidly with increasing distance from a structure		Not likely
Vapor flow described by Darcy's law	Porous media flow assumption.	Observations of fractured rock, fractured clay, karst, macropores, preferential flow channels.
Steady State convection	Flow not affected by barometric pressure, infiltration, etc.	Not likely
Uniform convective flow near the foundation	Flow rate does not vary by location	Not likely
Uniform convective velocity through crack or porous medium	No variation within cracks and openings and constant pressure field between interior spaces and the soil surface	Not likely
Significant convective transport only occurs in the vapor phase	Movement of soil water not included in vapor impact	Not likely
All contaminant vapors originating from directly below the basement will enter the basement, unless the floor and walls are perfect vapor barriers. (Makes model over est. vapors as none can flow around the building)	Model does not allow vapors to flow around the structure and not enter the building	Not likely
Contaminant vapors enter structures primarily through cracks and openings in the walls and foundation	Flow through the wall and foundation material itself neglected	Observe numbers of cracks and openings. Assessment of contribution from construction materials themselves not likely

- The presence or suspected presence of residual or free-product non-aqueous phase liquids (LNAPL, DNAPL, fuels, solvents, etc.) in the subsurface.
- The presence of heterogeneous geologic materials (other than the three layers allowed in the advanced spreadsheets) between the vapor source and building. The J&E Model does not apply to geologic materials that are fractured, contain macropores or other preferential pathways, or are composed of karst.

- Sites where significant lateral flow of vapors occurs. These can include geologic layers that deflect contaminants from a strictly upward motion and buried pipelines or conduits that form preferential paths. Significantly different permeability contrasts between layers are likely to cause lateral flow of vapors. The model assumes the source of contaminants is directly below the potential receptors.
- Very shallow groundwater where the building foundation is wetted by the groundwater.
- Very small building air exchange rates (e.g., $< 0.25/h$)
- Buildings with crawlspace structures or other significant openings to the subsurface (e.g., earthen floors, stone buildings, etc.). The EPA spreadsheet only allows for either slab on grade or basement construction.
- Contaminated groundwater sites with large fluctuations in the water table elevation. In these cases, the capillary fringe is likely to be contaminated; whereas in the groundwater source spreadsheets, the capillary fringe is assumed to be uncontaminated.

In theory the above limitations are readily conceptualized, but in practice the presence of these limiting conditions may be difficult to verify even when extensive site characterization data are available. Conditions that are particularly difficult to verify in the field include the presence of residual non-aqueous phase liquids (NAPLs) in the unsaturated zone and the presence and influence of macropores, fractures and other preferential pathways in the subsurface. Additionally, in the initial stages of evaluation, especially at the screening level, information about building construction and water table fluctuations may not be available. Even the conceptually simple assumptions (e.g., one-dimensional flow, lack of preferential pathways) may be difficult to assess when there are little site data available.

The vapor equilibrium models employed to estimate the vapor concentration at the source of soil contamination is applicable only if "low" concentrations of the compound(s) are sorbed to organic carbon in the soil, dissolved in soil moisture, and present as vapor within the air-filled soil pores (i.e., a three-phase system). The vapor equilibrium models do not account for a residual phase NAPLs. If residual phase contaminants are present in the soil column, the user is referred to either the NAPL-SCREEN or NAPL-ADV model (Appendix A), as appropriate.

In the case of contaminated groundwater, the vapor equilibrium model operates under the assumption that the contaminant is present at levels below the water solubility limit. If the user-defined soil concentration is greater than the soil saturation concentration (C_{sat}) or if the groundwater concentration is greater than the solubility limit (S), the equilibrium vapor concentration will be calculated at the value of C_{sat} or S as appropriate.

The user is also reminded that when estimating a risk-based soil concentration, the model will compare the calculated soil concentration with the soil saturation concentration above which a residual phase is likely to occur. The soil saturation concentration (C_{sat}) is calculated as in U.S. EPA (1996a and b). If the risk-based concentration is greater than the saturation concentration and the contaminant is a liquid or gas at the soil temperature, the final soil concentration will be set equal to the soil saturation concentration. This tends to eliminate the possibility of allowing a liquid residual phase to exist within the soil column, which may leach to the water table. If the risk-based soil concentration is greater than C_{sat} and the contaminant is a solid, the contaminant is not of concern for the vapor intrusion pathway.

Likewise, the groundwater models will compare the calculated risk-based groundwater concentration to the aqueous solubility limit of the compound. If the risk-based groundwater concentration is greater than the solubility limit, the contaminant is not of concern for the vapor intrusion pathway.

Finally, it should be recognized that the procedures used to estimate both the soil saturation concentration and the aqueous solubility limit do not consider the effects of multiple contaminants. The estimated values, therefore, may be artificially high such that a residual phase may actually exist at somewhat lower concentrations.

The procedures used to estimate the soil vapor permeability of the soil stratum in contact with the building floor and walls assume isotropic soils and steady-state soil moisture content. In addition, the calculations do not account for preferential vapor pathways due to soil fractures, vegetation root pathways, or the effects of a gravel layer below the floor slab or backfill. These items may act to increase the vapor permeability of in situ soils.

If in situ pneumatic tests are used to measure site vapor permeability, care must be taken to ensure adequate sampling to reduce the possibility of missing important soil structure effects due to anisotropy.

Single-point in situ pneumatic tests are typically conducted by measuring the pressure in a probe as a metered flow of air is passed through the probe and into the soil. Garbesi et al. (1996), however, demonstrated that soil vapor permeability increases with the sampling length scale. Using a dual-probe dynamic pressure sampling apparatus, Garbesi et al. (1996) demonstrated that the average soil vapor permeability typically increases up to a constant value as the distance between the source probe and detector probe increases. On a length scale typical of a house (3 to 10 m), use of the dual-probe sampling technique found that the soil permeability was approximately 10 to 20 times higher than that measured by the single-point method. Although arguably the most accurate means of determining in situ soil vapor permeability, the techniques of Garbesi et al. (1996) are complex and require specialized equipment.

Another method for determining the intrinsic permeability of soil is to conduct empirical measurements of the saturated hydraulic conductivity (K_s). These data are then input into Equation

26. The resulting value of k_i is then multiplied by the relative air permeability (k_{rg}) calculated by Equation 27 to yield the effective air permeability of the soil.

Estimation of the rise of the capillary zone is based on the equation for the rise of a liquid in a capillary tube. The procedure assumes that the interstitial space between the soil particles is equivalent to the capillary tube diameter and that the resulting rise of water occurs under steady-state soil column drainage conditions. In actuality, the height of the capillary zone is uneven or fingered due to the variation in the actual in situ particle size distribution. In addition, the groundwater models do not account for the episodic rise and fall of the water table or the capillary zone due to aquifer recharge and discharge. As constructed, the groundwater models do not allow the top of the capillary zone to be above the bottom of the building floor in contact with the soil. The user should be aware, however, that in reality the top of the capillary zone may rise to levels above the floor in some cases.

Diffusion across the capillary zone is estimated based on lumping vapor and aqueous-phase diffusion together within the calculation of the effective diffusion coefficient. To allow for vapor-phase diffusion within the capillary zone, the air-filled soil pores must be connected. In reality, the capillary zone may be comprised of a tension-saturated zone immediately above the water table and the deep portion of the vadose zone within which the soil water content is strongly dependent on the pressure head. Diffusion across the tension-saturated zone is dominated by liquid-phase diffusion, which is typically four orders of magnitude less than vapor-phase diffusion. Therefore, a large concentration gradient may exist between the top of the water table and the top of the tension-saturated zone (McCarthy and Johnson, 1993).

Lumping vapor and aqueous-phase diffusion together is a less-intensive, although less-rigorous, method for estimating the effective diffusion coefficient. The result is typically a higher effective diffusion coefficient relative to separate solutions for aqueous diffusion across the tension-saturated zone and both vapor and aqueous diffusion across the unsaturated portion of the vadose zone.

To minimize the possible overestimation of the effective diffusion coefficient, the soil air-filled porosity within the capillary zone is estimated based on the air-entry pressure head, which corresponds with the water-filled porosity at which the interstitial air-filled pores first become connected. The user should be aware that this procedure is inherently conservative if a significant concentration gradient exists across the tension-saturated zone. This conservatism may be somewhat offset in that the model does not consider any episodic rise in the level of the water table. During such events, water that had previously been part of the saturated zone (and hence contain higher contaminant concentrations) is redistributed in the vadose zone resulting in temporary elevations in soil gas concentrations.

The model assumes that all vapors from underlying soils will enter the building through gaps and openings in the walls, floor, and foundation. This implies that a constant pressure field is generated between the interior spaces and the soil surface and that the vapors are intercepted within the pressure field and transported into the building. This assumption is inherently conservative in

that it neglects periods of near zero pressure differentials (e.g., during mild weather when windows are left open).

As with the estimation procedure for soil vapor permeability, the model assumes isotropic soils in the horizontal direction; vertical anisotropy is accounted for by a series of isotropic soil strata above the top of contamination. Soil properties within the zone of soil contamination are assumed to be identical to those of the soil stratum directly above the contamination and extend downward to an infinite depth. Solute transports by convection (e.g., water infiltration) and by mechanical dispersion are neglected. Transformation processes (e.g., biodegradation, hydrolysis, etc.) are also neglected.

The J&E Model treats the entire building as a single chamber with instantaneous and homogeneous vapor dispersion. It therefore neglects contaminant sinks and the room-to-room variation in vapor concentration due to unbalanced mechanical and/or natural ventilation.

5.1 SOURCE VAPOR CONCENTRATION

As applied in the accompanying spreadsheets, the vapor equilibrium model employed to estimate the vapor concentration at the source of soil contamination is applicable in the limit of "low" concentrations where compounds are sorbed to organic carbon in the soil, dissolved in soil moisture, and present as vapor within the air-filled soil pores (i.e., a three-phase system). The model does not account for a residual phase (e.g., NAPL). If residual phase contaminants are present in the soil column, the user is referred to either the NAPL-SCREEN or NAPL-ADV model, as appropriate.

In the case of contaminated groundwater, the vapor equilibrium model operates under the assumption that the contaminant is present at levels below the water solubility limit. If the user-defined soil concentration is greater than the soil saturation concentration (C_{sat}) or if the groundwater concentration is greater than the solubility limit (S), the equilibrium vapor concentration will be calculated at the value of C_{sat} or S as appropriate.

The user is also reminded that when estimating a risk-based soil concentration, the model will compare the calculated soil concentration with the soil saturation concentration above which a residual phase is likely to occur. The soil saturation concentration (C_{sat}) is calculated as in U.S. EPA (1996a and b). If the risk-based concentration is greater than the saturation concentration and the contaminant is a liquid or gas at the soil temperature, the final soil concentration will be set equal to the soil saturation concentration. This tends to eliminate the possibility of allowing a liquid residual phase to exist within the soil column, which may leach to the water table. If the risk-based soil concentration is greater than C_{sat} and the contaminant is a solid, the contaminant is not of concern for the vapor intrusion pathway.

Likewise, the groundwater models will compare the calculated risk-based groundwater concentration to the aqueous solubility limit of the compound. If the risk-based groundwater

concentration is greater than the solubility limit, the contaminant is not of concern for the vapor intrusion pathway.

Finally, it should be recognized that the procedures used to estimate both the soil saturation concentration and the aqueous solubility limit do not consider the effects of multiple contaminants. The estimated values, therefore, may be artificially high such that a residual phase may actually exist at somewhat lower concentrations.

5.2 SOIL VAPOR PERMEABILITY

The procedures used to estimate the soil vapor permeability of the soil stratum in contact with the building floor and walls assumes isotropic soils and steady-state soil moisture content. In addition, the calculations do not account for preferential vapor pathways due to soil fractures, vegetation root pathways, or the effects of a gravel layer below the floor slab or backfill which may act to increase the vapor permeability with respect to in situ soils.

If in situ pneumatic tests are used to measure site vapor permeability, care must be taken to ensure adequate sampling to reduce the possibility of missing important soil structure effects due to anisotropy.

Single point in situ pneumatic tests are typically conducted by measuring the pressure in a probe as a metered flow of air is passed through the probe and into the soil. Garbesi et al. (1996), however, demonstrated that soil vapor permeability increases with the sampling length scale. Using a dual-probe dynamic pressure sampling apparatus, Garbesi et al. (1996) demonstrated that the average soil vapor permeability typically increases up to a constant value as the distance between the source probe and detector probe increases. On a length scale typical of a house (3 to 10 m) use of the dual-probe sampling technique found that the soil permeability was approximately 10 to 20 times higher than that measured by the single point method. Although arguably the most accurate means of determining in situ soil vapor permeability, the techniques of Garbesi et al. (1996) are complex and require specialized equipment.

Another method for determining the intrinsic permeability of soil is to conduct empirical measurements of the saturated hydraulic conductivity (K_s). These data are then input into Equation 26. The resulting value of k_i is then multiplied by the relative air permeability (k_{rg}) calculated by Equation 27 to yield the effective air permeability of the soil.

5.3 RISE OF AND DIFFUSION ACROSS THE CAPILLARY ZONE

Estimation of the rise of the capillary zone is based on the equation for the rise of a liquid in a capillary tube. The procedure assumes that the interstitial space between the soil particles is equivalent to the capillary tube diameter and that the resulting rise of water occurs under steady-state soil column drainage conditions. In actuality, the height of the capillary zone is uneven or fingered due to the variation in the actual in situ particle size distribution. In addition, the groundwater

models do not account for the episodic rise and fall of the water table or the capillary zone due to aquifer recharge and discharge. As constructed, the groundwater models do not allow the top of the capillary zone to be above the bottom of the building floor in contact with the soil. The user should be aware, however, that in reality the top of the capillary zone might rise to levels above the floor in some cases.

Diffusion across the capillary zone is estimated based on lumping vapor and aqueous-phase diffusion together within the calculation of the effective diffusion coefficient. To allow for vapor-phase diffusion within the capillary zone, the air-filled soil pores must be connected. In reality, the capillary zone may be comprised of a tension-saturated zone immediately above the water table and the deep portion of the vadose zone within which the soil water content is a strongly dependent on the pressure head. Diffusion across the tension-saturated zone is dominated by liquid-phase diffusion which is typically four orders of magnitude less than vapor-phase diffusion. Therefore, a large concentration gradient may exist between the top of the water table and the top of the tension-saturated zone (McCarthy and Johnson, 1993).

Lumping vapor and aqueous-phase diffusion together is a less intensive, although less rigorous, method for estimating the effective diffusion coefficient. The result is typically a higher effective diffusion coefficient relative to separate solutions for aqueous diffusion across the tension-saturated zone and both vapor and aqueous diffusion across the unsaturated portion of the vadose zone.

To minimize the possible over estimation of the effective diffusion coefficient, the soil air-filled porosity within the capillary zone is estimated based on the air-entry pressure head, which corresponds with the water-filled porosity at which the interstitial air-filled pores first become connected. The user should be aware that this procedure is inherently conservative if a significant concentration gradient exists across the tension-saturated zone. This conservatism may be somewhat offset in that the model does not consider any episodic rise in the level of the water table. During such events, water which had previously been part of the saturated zone (and hence contain higher contaminant concentrations) is redistributed in the vadose zone resulting in temporary elevations in soil gas concentrations.

5.4 DIFFUSIVE AND CONVECTIVE TRANSPORT INTO THE STRUCTURE

The following is a discussion of the major assumptions and limitations of the J&E Model for diffusive and convective vapor transport into buildings.

The model assumes that all vapors from underlying soils will enter the building through gaps and openings in the walls, floor, and foundation. This implies that a constant pressure field is generated between the interior spaces and the soil surface and that the vapors are intercepted within the pressure field and transported into the building. This assumption is inherently conservative in that it neglects periods of near zero pressure differentials (e.g., during mild weather when windows are left open).

As with the estimation procedure for soil vapor permeability, the model assumes isotropic soils in the horizontal direction; vertical anisotropy is accounted for by a series of isotropic soil strata above the top of contamination. Soil properties within the zone of soil contamination are assumed to be identical to those of the soil stratum directly above the contamination and extend downward to an infinite depth. Solute transports by convection (e.g., water infiltration) and by mechanical dispersion are neglected. Transformation processes (e.g., biodegradation, hydrolysis, etc.) are also neglected.

An empirical field study (Fitzpatrick and Fitzgerald, 1997) indicated that the model may be overly conservative for nonchlorinated species (e.g., benzene, toluene, ethylbenzene and xylene) but in some cases, may underpredict indoor concentrations for chlorinated species. The authors contribute the likely cause for this discrepancy to the significant biodegradation of the nonchlorinated compounds.

The J&E Model treats the entire building as a single chamber with instantaneous and homogeneous vapor dispersion. It therefore neglects contaminant sinks and the room-to-room variation in vapor concentration due to unbalanced mechanical and/or natural ventilation.

Finally, convective vapor flow from the soil matrix into the building is represented as an idealized cylinder buried below grade. This cylinder represents the total area of the structure below the soil surface (walls and floor). The total crack or gap area is assumed to be a fixed fraction of this area. Because of the presence of basement walls, the actual vapor entry rate is expected to be 50 to 100 percent of that provided by the idealized geometry (Johnson and Ettinger, 1991).

SECTION 6

INTERPRETATION OF RESULTS

The models described herein are theoretical approximations of complex physical and chemical processes and as such should not be used in a deterministic fashion (i.e., to generate a single outcome). At the least, a range of outcomes should be explored focusing on the most sensitive model input variables. In general, using the default values for input variables will result in higher indoor air concentrations and thus higher incremental risks or lower risk-based media concentrations. With a realistic range of outcomes, the risk manager may assess the uncertainty in the model predictions.

From a conceptual point of view, the vapor intrusion model provides a theoretical description of the processes involved in vapor intrusion from subsurface soils or groundwater into indoor structures. A combination of modeling and sampling methods is also possible to reduce the uncertainty of the calculated indoor air concentrations. Typically this involves field methods for measuring soil gas very near or below an actual structure. It should be understood, however, that soil gas sampling results outside the footprint of the building may or may not be representative of the soil gas concentrations directly below the structure. For solid building floors in contact with the soil (e.g., concrete slabs), the soil gas directly beneath the floor may be considerably higher than that adjacent to the structure. This is typically due to a vapor pooling effect underneath the near impermeable floor. Once a representative average concentration is determined, all vapor directly below the areal extent of the building is presumed to enter the structure. The soil gas concentration, along with the building ventilation rate and the soil gas flow rate into the building, will determine the indoor concentration. When using the soil gas models, it must be remembered that no analysis has been made concerning the source of contamination. Therefore, the calculated indoor concentration is assumed to be steady-state. The procedures described in API (1998) can be used to calibrate the diffusion transport considerations of the J&E Model as well as for calibrating the Model for transformation processes (e.g., biodegradation). The reader is also referred to U.S. EPA (1992) for a more detailed discussion of applying soil gas measurements to indoor vapor intrusion.

Finally, calibration and verification of the model have been limited due to the paucity of suitable data. Research is needed to provide spatially and temporally correlated measurements during different seasons, at different locations, with different buildings, and over a range of different contaminants such that the accuracy of the model may be determined. Appendix E contains bibliography and references.

APPENDIX A

USER'S GUIDE FOR NON-AQUEOUS PHASE LIQUIDS

Purpose

The NAPL-SCREEN and NAPL-ADV models are designed to forward calculate incremental cancer risks or noncarcinogenic hazard quotients due to subsurface soil vapor intrusion into buildings. The models are specifically designed to handle nonaqueous phase liquids or solids in soils. The user may specify up to 10 soil contaminants, the concentrations of which form a residual phase mixture. A residual phase mixture occurs when the sorbed phase, aqueous phase, and vapor phase of each chemical have reached saturation in soil. Concentrations above this saturation limit for all of the specified chemicals of a mixture will result in a fourth or residual phase (i.e., nonaqueous phase liquid or solid).

Other vapor intrusion models (SL-SCREEN, SL-ADV, SG-SCREEN, SG-ADV, GW-SCREEN, and GW-ADV) handled only a single contaminant and only when the soil concentration was at or below the soil saturation limit (i.e., a three-phase system). Use of these models when a residual phase is present, results in an overprediction of the soil vapor concentration and subsequently the building vapor concentration.

Residual Phase Theory

The three-phase system models estimate the equilibrium soil vapor concentration at the emission source (C_{source}) using the procedures from Johnson et al. (1990):

$$C_{source} = \frac{H'_{TS} C_R \rho_b}{\theta_w + K_d \rho_b + H'_{TS} \theta_a} \quad (1)$$

where:	C_{source}	=	Vapor concentration at the source of contamination, g/cm ³
	H'_{TS}	=	Henry's law constant at the soil temperature, dimensionless
	C_R	=	Initial soil concentration, g/g
	ρ_b	=	Soil dry bulk density, g/cm ³
	θ_w	=	Soil water-filled porosity, cm ³ /cm ³
	K_d	=	Soil-water partition coefficient, cm ³ /g (= $K_{oc} \times f_{oc}$)
	θ_a	=	Soil air-filled porosity, cm ³ /cm ³
	K_{oc}	=	Soil organic carbon partition coefficient, cm ³ /g
	f_{oc}	=	Soil organic carbon weight fraction.

In Equation 1, the equilibrium vapor concentration is proportional to the soil concentration up to the soil saturation limit. When a residual phase is present, however, the vapor concentration is independent of the soil concentration but proportional to the mole fraction of the individual component of the residual phase mixture. In this case, the equilibrium vapor concentration must be calculated numerically for a series of time-steps. For each time-step, the mass of each constituent that is volatilized is calculated using Raoult's law and the appropriate mole fraction. At the end of each time-step, the total mass lost is subtracted from the initial mass and the mole fractions are recomputed for the next time-step.

The NAPL-SCREEN and NAPL-ADV models use the procedures of Johnson et al. (2001) to calculate the equilibrium vapor concentration at the source of emissions for each time-step. Within each model, the user-defined initial soil concentration of each component in the mixture is checked to see if a residual phase is present. This is done by calculating the product of the activity coefficient of component i in water (α_i) and the mole fraction of i dissolved in soil moisture (y_i) such that:

$$\alpha_i y_i = \frac{M_i}{\left[\left(P_i^v(T_S) \theta_a V / RT_S \right) + \left(M^{H_2O} / \alpha_i \right) + \left(K_{d,i} M_{soil} / \alpha_i MW_{H_2O} \right) \delta(M^{H_2O}) \right]} \quad (2)$$

where:

M_i	=	Initial moles of component i in soil, moles
$P_i^v(T_S)$	=	Vapor pressure of i at the average soil temperature, atm
θ_a	=	Soil air-filled porosity, cm ³ /cm ³
V	=	Volume of contaminated soil, cm ³
R	=	Ideal gas constant, 82.05 atm-cm ³ /mol-°K
T_S	=	Average soil temperature, °K
$M_2^{H_2O}$	=	Total moles in soil moisture dissolved phase, moles
α_i	=	Activity coefficient of i in water, unitless
$K_{d,i}$	=	Soil-water partition coefficient of i , cm ³ /g
M_{soil}	=	Total mass of contaminated soil, g
MW_{H_2O}	=	Molecular weight of water, 18 g/mol
$\delta(M_2^{H_2O})$	=	1 if $M_2^{H_2O} > 0$, and
$\delta(M_2^{H_2O})$	=	0 if $M_2^{H_2O} = 0$.

If the sum of all the values of $\alpha_i y_i$ for all of the components of the mixture is less than 1, the mixture does not contain a residual phase and the models are not applicable. In such cases, the SL-SCREEN or SL-ADV model can be used to estimate the building concentration.

Once it has been determined that a residual phase does exist, the mole fraction of each component (x_i) is determined by iteratively solving Equations 3 and 4 subject to the constraint that the sum of all the mole fractions equals unity ($\sum x_i = 1$):

$$x_i = \frac{M_i}{\left[\left(P_i^v(T_S) \theta_a V / RT_S \right) + M^{HC} + \left(M^{H_2O} / \alpha_i \right) + \left(K_{d,i} M_{soil} / \alpha_i MW_{H_2O} \right) \delta(M^{H_2O}) \right]} \quad (3)$$

and,

$$x_i = \frac{M_i^{HC}}{M^{HC}} \quad (4)$$

where M_i^{HC} is the number of moles of component i in residual phase and M^{HC} is the total number of moles of all components in residual phase. The solution is simplified by assuming that $M_2^{H_2O}$ is approximately equal to the number of moles of water in the soil moisture. With the mole fraction of each component at the initial time-step, the equilibrium vapor concentration at the source of emissions is calculated by Raoult's law:

$$C_{source} = \frac{x_i P_i^v(T_S) MW_i}{RT_S} \quad (5)$$

where MW_i is the molecular weight of component i (g/mol).

At the beginning of each succeeding time-step, the number of moles of each chemical remaining in the soil from the previous time-step are again checked to see if a residual phase is present using Equation 2. When a residual phase is no longer present, the equilibrium vapor concentration at the source of emissions is calculated by:

$$C_{source} = \frac{\alpha_i y_i P_i^v(T_S) MW_i}{RT_S} \quad (6)$$

Ancillary Calculations

The activity coefficient of component i in water (α_i) is estimated from its solubility. Because hydrocarbons are typically sparingly soluble in water, the following generalization has been applied to compounds that are liquid or solid at the average soil temperature:

$$\alpha_i = (1/y_i) = (55.55 \text{ moles/L}) MW_i / S_i \quad (7)$$

where S_i is the solubility of component i (g/L). For gases at the average soil temperature, the corresponding relationship is:

$$\alpha_i = (1/y_i) \left(1 \text{ atm} / P_i^v(T_S) \right) = (55.55 \text{ moles/L}) \left(MW_i (1 \text{ atm}) / S_i P_i^v(T_S) \right) \quad (8)$$

Assuming that the vapor behaves as an ideal gas with a relatively constant enthalpy of vaporization between 70°F and the average soil temperature, the Clausius-Clapeyron equation can be used to estimate the vapor pressure at the desired temperature:

$$P^v(T_S) = P^v(T_R) \times \exp \left[\left(\frac{T_B \times T_R}{(T_B - T_R)} \right) \left(\frac{1}{T_S} - \frac{1}{T_R} \right) \ln \left(\frac{P^v(T_R)}{P_B} \right) \right] \quad (9)$$

where: $P^v(T_S)$ = Vapor pressure at the desired temperature T_S , atm
 $P^v(T_R)$ = Vapor pressure at the reference temperature T_R , atm

T_B	=	Normal boiling point, °K
T_R	=	Vapor pressure reference temperature, °K
T_S	=	The desired temperature, °K
P_B	=	Normal boiling point pressure = 1 atm.

Building Concentration

The vapor concentration within the building or enclosed space ($C_{building}$) is calculated using the steady-state solution of Johnson and Ettinger (1991) such that:

$$C_{building} = \alpha C_{source} \quad (10)$$

The steady-state attenuation coefficient (α) is calculated by:

$$\alpha = \frac{\left[\left(\frac{D_T^{eff} A_B}{Q_{building} L_T} \right) \times \exp\left(\frac{Q_{soil} L_{crack}}{D^{crack} A_{crack}} \right) \right]}{\left[\exp\left(\frac{Q_{soil} L_{crack}}{D^{crack} A_{crack}} \right) + \left(\frac{D_T^{eff} A_B}{Q_{building} L_T} \right) + \left(\frac{D_T^{eff} A_B}{Q_{soil} L_T} \right) \left[\exp\left(\frac{Q_{soil} L_{crack}}{D^{crack} A_{crack}} \right) - 1 \right] \right]} \quad (11)$$

where:

α	=	Steady-state attenuation coefficient, unitless
D_T^{eff}	=	Total overall effective diffusion coefficient, cm ² /s
A_B	=	Area of the enclosed space below grade, cm ²
$Q_{building}$	=	Building ventilation rate, cm ³ /s
L_T	=	Source-building separation, cm
Q_{soil}	=	Volumetric flow rate of soil gas into the enclosed space, cm ³ /s
L_{crack}	=	Enclosed space foundation or slab thickness, cm
A_{crack}	=	Area of total cracks, cm ²
D^{crack}	=	Effective diffusion coefficient through the cracks, cm ² /s.

The reader is referred to Section 2.5 of this Guidance for a more detailed discussion of the derivation of Equation 11 and procedures for determining values for model input parameters. Except for the calculation of the equilibrium vapor concentration at the source of emissions, NAPL-SCREEN is identical to the three-phase model SL-SCREEN and NAPL-ADV is identical to the three-phase model SL-ADV.

The NAPL-SCREEN and NAPL-ADV models explicitly solve for the time-averaged building concentration over the exposure duration using a forward finite-difference numerical approach. For each time-step δt :

$$M_i(t + \delta t) = M_i(t) - \delta t (C_{building} \times Q_{building} / MW_i) \quad (12)$$

where $M_i(t)$ is the number of moles of component i in soil at the previous time and $M_i(t+\delta t)$ is the number of moles at the new time. The time-step interval is variable as a function of the percent of mass lost over the time-step. The user may specify a minimum and maximum percent loss allowed; these values are applied to the single component of the residual phase mixture with the highest mass loss rate during each time-step interval. If the user-specified maximum percent loss is exceeded, the next time-step interval is reduced by half; likewise, if the user-specified minimum percent loss is not achieved, the next time-step interval is increased by a factor of two. The instantaneous building concentration at time = t is calculated using Equation 10 for each time-step. The time-averaged building concentration is estimated using a trapezoidal approximation of the integral.

Model Assumptions and Limitations

The NAPL-SCREEN and NAPL-ADV models operate under the assumption that sufficient time has elapsed since the time of initial soil contamination for steady-state conditions to have been achieved. This means that the subsurface vapor plume has reached the bottom of the enclosed space floor and that the vapor concentration has reached its maximum value. An estimate of the time required to reach near steady-state conditions (τ_{ss}) can be made using the following equations from API (1998):

$$\tau_{ss} \cong \frac{R_v \theta_a L_T^2}{D^{eff}} \quad (13)$$

and,

$$R_v = 1 + \frac{\theta_w}{\theta_a H'_{TS}} + \frac{\rho_b K_d}{\theta_a H'_{TS}} \quad (14)$$

and,

$$D^{eff} = D_a \frac{\theta_a^{10/3}}{n^2} + \left(\frac{D_w}{H'_{TS}} \right) \frac{\theta_w^{10/3}}{n^2} \quad (15)$$

where R_v is the unitless vapor phase retardation factor, L_T is the source-building separation (cm), D^{eff} is the effective diffusion coefficient (cm^2/s), D_a is the diffusivity in air (cm^2/s), D_w is the diffusivity in water (cm^2/s), and n is the soil total porosity (cm^3/cm^3). The NAPL-SCREEN and NAPL-ADV models are applicable only when the elapsed time since initial soil contamination meets or exceeds the value of τ_{ss} (see **Using the Models**).

Emission source depletion is calculated by estimating the rate of vapor loss as a function of time such that the mass lost at each time-step is subtracted from a finite mass of contamination at the source. This requires the model user to estimate the dimensions of the emission source, e.g., the length, width, and thickness of the contaminated zone. The model should only be used, therefore,

when the extent of soil contamination has been sufficiently determined. It should be noted that because the NAPL-SCREEN and NAPL-ADV models are one-dimensional, the areal extent of soil contamination (i.e., length \times width) can be less than but not greater than the areal extent of the building floor in contact with the soil.

Each model treats the contaminated zone directly below the building as a box containing a finite mass of each specified compound. The initial contamination contained within the box is assumed to be homogeneously distributed. After each time-step, the remaining contamination is assumed to be instantaneously redistributed within the box to homogeneous conditions. The diffusion path length from the top of contamination to the bottom of the enclosed space floor therefore remains constant with time. Use of this simplifying assumption means that the degree of NAPL soil saturation is not required in the calculation of the total overall effective diffusion coefficient (D_T^{eff}).

As time proceeds, the concentration of the mixture of compounds within the soil column may reach the soil saturation limit. Below this point, a residual phase will cease to exist and the vapor concentration of each chemical will decrease proportional to its total volume soil concentration. Theoretically, the vapor concentration will decrease asymptotically, approaching but never reaching zero. Because of the nature of the numerical solution to equilibrium vapor concentration, however, compounds with high effective diffusion coefficients (e.g., vinyl chloride) may reach zero soil concentrations while other less volatile contaminants will not. If the initial soil concentrations are significantly higher than their respective values of the soil saturation concentration, a residual phase may persist up to the user-defined exposure duration.

Model assumptions and limitations concerning vapor transport and vapor intrusion into buildings are those specified for the three-phase models.

Using the Models

Each model is constructed as a Microsoft[®] Excel workbook containing five worksheets. The DATENTER worksheet is the data entry worksheet and also provides model results. The VLOOKUP worksheet contains the “Chemical Properties Lookup Table” with listed chemicals and associated chemical and toxicological properties. It should be noted that the toxicological properties for many of these chemicals were derived by route-to-route extrapolation. In addition, the VLOOKUP worksheet includes the “Soil Properties Lookup Table” containing values for model intermediate variables used in estimating the soil vapor permeability. The CHEMPROPS worksheet provides a summary of the chemical and toxicological properties of the soil contaminants selected by the user. In addition, the CHEMPROPS worksheet provides calculated values for the soil saturation concentration (C_{sat}) and the time to reach steady-state conditions (τ_{ss}) once all required data are entered into the DATENTER worksheet. The INTERCALCS worksheet contains calculated values of intermediate model variables. Finally, the COMPUTE worksheet contains the numerical solutions for equilibrium vapor concentration and building vapor concentration as a function of time.

Both models use the Microsoft® SOLVER add-in algorithms to simultaneously solve Equations 3 and 4 for each of up to 10 chemicals specified by the user. In order to run NAPL-SCREEN or NAPL-ADV, the SOLVER add-in must be loaded into EXCEL. The user is referred to the EXCEL instructions for loading the SOLVER add-in.

On the DATENTER worksheet, the user may specify up to 10 soil contaminants by CAS number along with associated soil concentrations in units of mg/kg. The CAS number entered must match exactly one of the 93 chemicals listed in the VLOOKUP worksheet or the error message “CAS No. not found” will appear in the “Chemical” box. If the list of chemicals and concentrations entered does not constitute a residual phase, the error message in Figure 1 will appear after starting the model.

Figure 1. Residual Phase Error Message

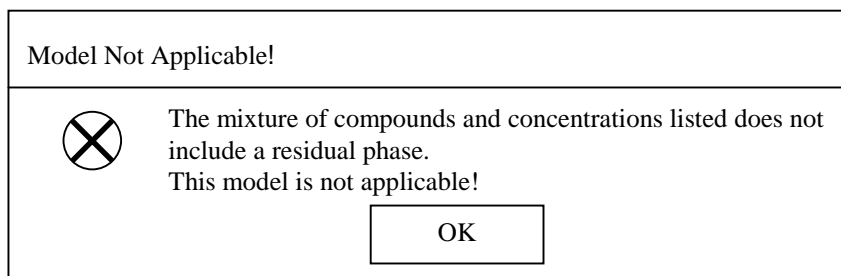

If this error message box appears, use either the SL-SCREEN or SL-ADV model to estimate subsurface vapor intrusion into the building.

After starting the model calculations, other error message boxes may appear if data entry values are missing on the DATENTER worksheet or if entered values do not conform to model assumptions. If such an error message box appears, fill-in missing data or re-enter data as appropriate. If entered data values are outside the expected range or if text values are entered where numeric values are expected, the model calculation macro will be suspended and the run-time error message in Figure 2 will appear.

Figure 2. Run-Time Error Message

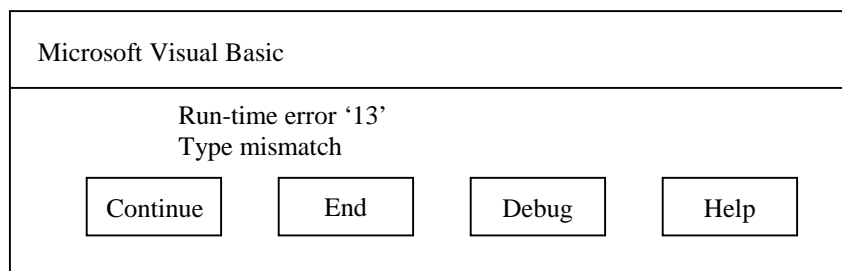

Should this error message appear, click on the “End” button to terminate the macro and return to the DATENTER worksheet. At this point, the user should review all of the entered values and make the appropriate corrections.

In addition to contaminant data, soil properties data, zone of contamination data, and exposure assumptions must also be specified in the DATENTER worksheet. Similar to the SL-SCREEN three-phase model, the NAPL-SCREEN model allows for only one soil stratum between the top of contamination and the bottom of the building floor in contact with the soil. In addition, the NAPL-SCREEN model uses built-in default values for all building variables (e.g., building dimensions, air exchange rate, total crack area, etc.). These default values are for single-family detached residences; therefore, the NAPL-SCREEN model should only be used for the residential exposure scenario.

The NAPL-ADV model, like the SL-ADV model, allows for up to three different soil strata between the top of contamination and the bottom of the building floor. In addition, the NAPL-ADV model allows the user to enter values for all model variables. This allows for the estimation of soil vapor intrusion into buildings other than single-family residences.

For each model, the user must also enter the duration of the first (initial) time-step interval. The maximum and minimum change in mass for each time-step must also be specified. The values of the initial time-step interval, and the maximum and minimum change in mass are important. If these values are too low, the model will calculate very small increments in the mass lost over time which will greatly extend the run-time of the model. In general, if the concentrations of the least volatile chemicals in the mixture are well above their respective values of the soil saturation concentration, a relatively large initial time-step interval, and maximum and minimum change in mass should be specified (e.g., 4 days, 10%, and 5%, respectively). For comparison, the value of the soil saturation concentration (C_{sat}) for each chemical specified by the user may be found in the CHEMPROPS worksheet after all data have been entered on the DATENTER worksheet. If, however, the soil concentrations of the most volatile constituents are very close to their respective saturation limits, large values of the initial time-step interval, and the maximum and minimum change in mass will result in the error message in Figure 3 after starting the model.

Figure 3. Time-Step and Change in Mass Error Message

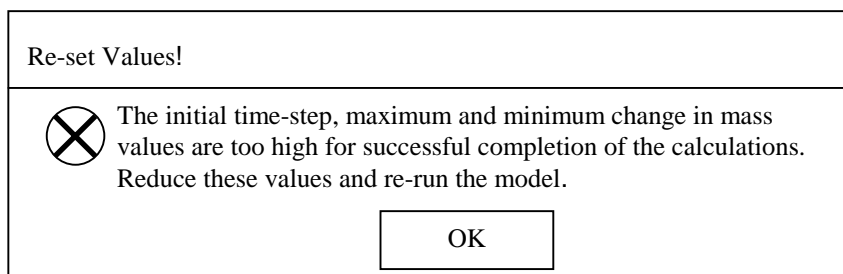

Should this error message occur, reduce the value of the initial time-step interval and the values of the maximum and minimum change in mass to smaller values and re-run the model. The error message will be repeated until the values of these variables are sufficiently small.

After all required data are entered into the DATENTER worksheet, the model is run by clicking on the “Execute Model” button which will change from reading “Execute” to “Stand by...”. In addition, the message box in Figure 4 will appear keeping a running count of the number of residual phase time-step solutions achieved by the model.

Figure 4. Progress of Calculations Message Box

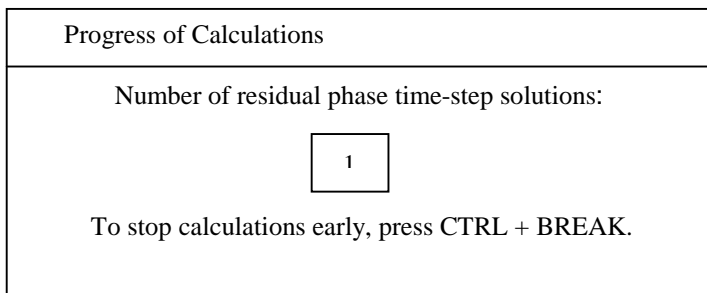

Each SOLVER trial solution can also be seen running in the status bar at the bottom of the screen. When the model is finished calculating, the “Execute Model” button will read “Done” and the Progress of Calculations message box in Figure 4 will disappear. The time-averaged building concentrations, incremental cancer risks, and/or hazard quotients will then be displayed under the “RESULTS” section of the DATENTER worksheet. In addition, an “X” will appear beside the calculated risk or hazard quotient of each contaminant for which a route-to-route extrapolation was employed. It should be noted that a route-to-route extrapolation was used for any chemical without a unit risk factor (URF) or a reference concentration (RfC). Therefore, the user should evaluate the resulting cancer risks and/or hazard quotients of such chemicals. Once a solution has been achieved and the user wishes to save the results, the file should be saved under a new file name. If the user wishes to delete all of the data previously entered on the DATENTER worksheet, this may be accomplished by clicking on the “Clear Data Entry Sheet” button.

Stopping Calculations Early

As mentioned previously, the user-defined values of the initial time-step interval, and the maximum and minimum change in mass should be chosen carefully. If the model run-time is excessive or if the user simply wishes to terminate the calculations, the model may be stopped by pressing CTRL + BREAK. If termination occurs in-between SOLVER solutions, the message box in Figure 5 will appear.

Figure 5. Code Interruption Message Box

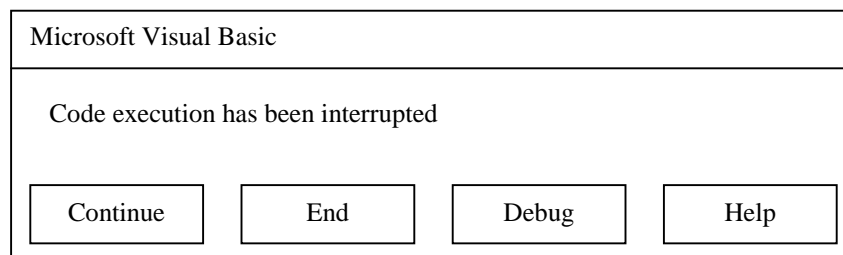

If this message box appears, click on the “End” button to terminate the macro.

If the termination occurs during a SOLVER solution, the message box in Figure 6 will appear. If this message box appears, click on the “Stop” button. This will stop the SOLVER solution but not the program macro. Depending on where in the macro code the interruption occurs, the model may continue to operate after clicking on the “Stop” button in Figure 6. If this happens, press CTRL + BREAK again. At this point, the message box in Figure 5 will appear; click on the “End” button to terminate the macro.

Figure 6. Solver Interruption Message Box

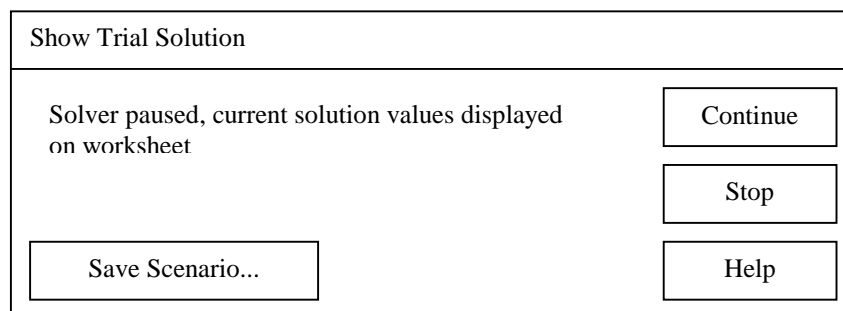

At this point, the user may examine the model results up to the point of termination on the COMPUTE worksheet. The values of the “Change in mass”, the “Time-step interval”, and the “Cumulative time” should be examined to determine if changes are necessary in the values of the initial time-step interval, and the maximum and minimum change in mass. After these or any other values are changed on the DATENTER worksheet, the model may be re-run by clicking on the “Execute Model” button.

Step-By-Step Procedures for Running the Models

The following gives the step-by-step procedures for running either the NAPL-SCREEN or the NAPL-ADV model.

1. On the DATENTER worksheet, enter the CAS number of each soil contaminant in the residual phase mixture (do not include dashes in the CAS numbers). After the CAS numbers have been entered, the respective chemical names will appear in the “Chemical” box.
2. On the DATENTER worksheet, enter the soil concentration of each contaminant in units of mg/kg as well as values for all remaining variables except the “Initial time-step”, the “Maximum change in mass”, and the “Minimum change in mass”.
3. On the CHEMPROPS worksheet, note the calculated values of the “Time to steady state” (τ_{ss}) for each contaminant. Calculated values of the time-averaged building concentration and associated risks for contaminants with values of τ_{ss} greater than the actual elapsed time since initial soil contamination will be artificially high.
4. On the CHEMPROPS worksheet, note the calculated values of the “Soil saturation concentration” (C_{sat}) for each contaminant. Use these data to help determine appropriate user-defined values for the initial time-step, and the maximum and minimum change in mass. Typical values for these variables might be 2 days, 7%, and 4%, respectively, but may be considerably higher or lower depending on the number of chemicals in the analysis and the starting soil concentrations (see the discussion on page 8).
5. Click on the “Execute Model” button to begin the model calculations. If data are missing on the DATENTER worksheet, or entered values do not conform to model assumptions, an error message box will appear after the model is started informing the user of the type of error encountered. Enter the appropriate values on the DATENTER worksheet and re-run the model. Once the model has successfully started, note the number of residual phase time-step solutions achieved by the model in the Progress of Calculations message box (Figure 4). Use this information to help establish new values for the initial time-step interval and the maximum and minimum change in mass if the number of time-steps needs to be increased or decreased.
6. When the NAPL-SCREEN model has finished calculating, check column “O” on the COMPUTE worksheet to determine how many time-steps were calculated while a residual phase was present; one time-step is equal to one row (when using the NAPL-ADV model check column “P”). A residual phase is present when the value in column “O” or “P”, as appropriate, is equal to 1.000. In general, a greater number of time-steps means a more accurate estimate of the time-averaged building concentration. If the starting soil concentrations of the most volatile contaminants are very close to their respective values of C_{sat} , a minimum of 5 to 10 time-steps should be calculated by the model. For all other cases, a reasonable number of time-steps is between 40 and 70. To increase the number of time-steps calculated by the model, decrease the values of the initial time-step interval and the maximum and minimum change in mass. The opposite is true when the number of time-steps is to be decreased.

7. If the message box in Figure 1 appears after starting the model, the mixture of compounds and concentrations specified does not include a residual phase. Use the SL-SCREEN or SL-ADV model to calculate indoor air concentrations and risks for each contaminant separately.
8. If the message box in Figure 3 appears after starting the model, reduce the input values of the initial time-step, and maximum and minimum change in mass and re-run the model.
9. If the run-time of the model is excessive, terminate the model macro by pressing CTRL + BREAK (see the discussion under **Stopping Calculations Early** on pages 9 and 10). Examine the calculated values of the “Change in mass”, the “Time-step interval”, and the “Cumulative time” on the COMPUTE worksheet. Re-enter new lower values for the initial time-step interval, and the maximum and minimum change in mass and re-run the model.
10. After successful completion of a model run, note the calculated values of the “Time-averaged building concentration”, “Incremental cancer risk”, and/or “Hazard quotient” in the “RESULTS” section of the DATENTER worksheet. Also note for which contaminants a route-to-route extrapolation was employed. If the model results are to be retained, save the file under a new file name.

Adding, Deleting or Revising Chemical Data

Additional chemicals can be listed in the “Chemical Properties Lookup Table” within the VLOOKUP worksheet. To add, delete or revise chemicals, the VLOOKUP worksheet must be unprotected using the password “ABC” in capital letters. Row number 171 is the last row that may be used to add new chemicals. If new chemicals are added or chemicals deleted, the user must sort all the data in the “Chemical Properties Lookup Table” (except the column headers) in ascending order by CAS number. After sorting is complete, the worksheet should again be protected.

APPENDIX B

CHEMICAL PROPERTIES LOOKUP TABLE AND REFERENCES

CAS No.	Chemical	Organic Carbon Partition Coefficient K _{oc} (cm ³ /g)	Diffusivity in Air D _a (cm ² /s)	Diffusivity in Water D _w (cm ² /s)	Pure Component Water Solubility S (mg/L)	Henry's Law Constant H ₁ (unitless)	Henry's Law Constant at Reference Temperature H ₁ (atm·m ³ /mol)	Henry's Law Constant Reference Temperature T _R (°C)	Normal Boiling Point T _b (K)	Critical Temperature T _c (K)	Enthalpy of Vaporization at the Normal Boiling Point ΔH _{vap} (cal/mol)	Unit Risk Factor URF (ug/m ³) ⁻¹	Reference Concentration RIC (mg/m ³)	Density, ρ _l (g/cm ³)	Physical State at soil Temp (S.L.G.)	Vapor Pressure VP (mm Hg)	Molecular Weight M _w (g/mole)	URF extrapolated (X)	Rfc extrapolated (X)
74873	Methyl chloride (chlorome	2.12E+00	2 1.26E-01	2 6.50E-06	2 5.33E+03	3 3.11E-01	3 8.80E-03	25 249.00	4 416.25	4 5.11E+03	4 1.00E-06	3 9.00E-02	3 0.9159	8 L	4.30E+03	5.05E+01	3		
74938	Hydrogen cyanide	3.80E+00	2 1.93E-01	2 2.10E-05	3 5.44E+03	3 1.93E-04	3 1.93E-04	25 299.00	4 456.70	4 6.88E+03	7 0.00E+00	3 3.00E-03	3 0.9876	4 L	7.42E+02	2.70E+01	3		
74953	Methylene bromide	2.43E+00	2 4.30E-02	2 8.44E-06	2 1.19E+04	3 3.62E-02	3 8.59E-04	25 370.00	4 583.00	6 7.87E+03	4 1.00E-00	3 3.50E-02	3 2.4969	4 L	4.44E+01	1.74E+02	3	X	
75003	Chloroethane (ethyl chlori	4.40E+00	2 2.71E-01	2 1.15E-05	2 5.68E+03	3 3.61E-01	3 8.80E-03	25 285.30	4 460.40	4 5.88E+03	4 8.29E-07	3 1.00E+01	3 0.3242	8 L	1.01E+03	6.45E+01	3	X	
75014	Vinyl chloride (chloroetha	1.86E+01	1 1.06E-01	1 1.23E-05	1 8.80E+03	3 1.10E+00	3 2.69E-02	25 2.59E+02	1 4.32E+02	1 5.25E+03	4 8.80E-06	3 1.00E+01	3 9.11E-01	4 G	2.98E+03	6.25E+01	3		
75058	Acetonitrile	4.20E+00	2 1.28E-01	2 1.66E-05	2 1.00E+06	3 1.42E+03	3 3.45E-05	25 354.60	4 545.50	4 7.11E+03	4 4.00E+00	3 6.00E-02	3 0.7857	4 L	9.11E+01	4.11E+01	3		
75070	Acetaldehyde	1.06E+00	2 1.24E-01	2 1.41E-05	2 1.00E+06	3 3.23E+03	3 7.87E-05	25 293.10	4 466.00	4 6.16E+03	4 2.20E-06	3 9.00E-03	3 0.7857	8 L	9.02E+02	4.41E+01	3		
75092	Methylene chloride	1.10E+01	1 1.01E-01	1 1.17E-05	1 1.30E+04	3 8.96E-02	3 2.18E-03	25 3.13E+02	1 5.10E+02	1 6.71E+03	1 4.70E-07	3 3.01E+00	4 L	1.33E+00	4.43E+02	8.49E+01	3		
75150	Carbon disulfide	4.57E+01	1 1.04E-01	1 1.00E-05	1 1.19E+03	3 1.24E+00	3 3.02E-02	25 3.19E+02	1 5.52E+02	1 6.39E+03	1 0.00E+00	3 7.00E-01	4 L	3.59E+02	7.61E+01	3			
75218	Ethylene oxide	1.93E+00	2 1.04E-01	2 1.45E-05	2 3.04E+05	3 2.27E-02	3 5.54E-04	25 283.80	4 469.00	4 8.10E+03	4 1.00E+04	3 0.00E+00	3 0.3146	8 L	1.25E+03	4.41E+01	3		
75252	Bromoform	8.71E+01	1 1.48E-02	1 1.03E-05	1 3.10E+03	3 2.41E-02	3 5.88E-04	25 4.22E+02	1 6.98E+02	1 9.48E+03	1 1.10E-06	3 7.00E-02	3 2.90E+00	4 L	5.51E+00	2.53E+02	3		X
75274	Bromodichloromethane	1.53E+01	1 2.98E-02	1 1.06E-05	1 6.74E+03	3 6.54E-02	3 1.60E-03	25 3.63E+02	1 5.86E+02	1 8.01E+03	1 1.77E-05	3 7.00E-02	3 1.98E+00	4 L	5.00E+01	1.64E+02	3	X	
75296	2-Chloropropane	9.14E+00	2 8.88E-02	2 1.01E-05	2 3.73E+03	3 5.93E-01	3 1.45E-02	25 308.70	4 485.00	6 6.29E+03	4 0.00E+00	3 1.02E-01	3 0.8617	4 L	5.23E+02	7.85E+01	3		
75343	1,1-Dichloroethane	3.16E+01	1 7.42E-02	1 1.05E-05	1 5.06E+03	3 2.30E-01	3 5.61E-03	25 3.31E+02	1 5.23E+02	1 6.90E+03	1 0.00E+00	3 5.00E-01	3 1.18E+00	4 L	2.27E+02	9.90E+01	3		
75354	1,1-Dichloroethylene	5.89E+01	1 9.00E-02	1 1.04E-05	1 2.25E+03	3 1.07E+00	3 2.60E-02	25 3.05E+02	1 5.76E+02	1 6.25E+03	1 0.00E+00	3 2.00E-01	3 1.21E+00	4 L	6.00E+02	9.69E+01	3		
75456	Chlorodifluoromethane	4.79E+01	2 1.01E-01	2 1.28E-05	2 2.00E+00	3 1.10E+00	3 2.70E-02	25 232.40	4 369.30	4 4.84E+03	6 0.00E+00	3 5.00E+01	3 1.209	8 L	7.48E+03	8.65E+01	3		
75694	Trichlorofluoromethane	4.97E+02	2 8.70E-02	2 9.70E-06	2 1.10E+03	3 3.97E+00	3 9.68E-02	25 296.70	4 471.00	6 6.00E+03	6 0.00E+00	3 7.00E-01	3 1.4879	8 L	8.03E+02	1.37E+02	3		
75718	Dichlorodifluoromethane	4.52E+02	2 6.85E-02	2 9.92E-06	2 2.80E+02	3 1.40E+01	3 3.42E-01	25 243.20	4 381.95	4 9.42E+03	6 0.00E+00	3 2.00E-01	3 1.33	8 L	4.85E+03	1.21E+02	3		
76131	1,1,2-Trichloro-1,1,2-triflu	1.11E+04	2 7.80E-02	2 8.20E-06	2 1.70E+02	3 1.97E-01	3 4.80E-01	25 320.70	4 487.30	4 6.48E+03	4 0.00E+00	3 3.01E+01	3 1.5635	8 L	3.32E+02	1.87E+02	3		
76448	Hexachloro	1.41E+06	1 1.12E-02	1 5.69E-06	1 1.80E-01	3 6.05E+01	3 1.48E+00	25 6.04E+02	1 8.48E+02	1 1.30E+04	1 1.30E-03	3 NA	4 S	4.00E+04	3.73E+02	3		X	
77474	Hexachlorocyclopentadiene	2.00E+05	1 1.61E-02	1 7.21E-06	1 1.80E+00	3 1.10E+00	3 2.69E-02	25 5.12E+02	1 7.48E+02	1 1.09E+04	1 0.00E+00	3 2.00E-04	3 1.70E+00	4 L	6.00E+02	2.73E+02	3		
78831	Isobutanol	2.59E+00	2 8.60E-02	2 9.30E-06	2 8.50E+04	3 4.83E-04	3 1.18E-05	25 381.04	4 547.78	4 1.09E+04	6 0.00E+00	3 1.05E+00	3 0.8018	4 L	1.05E+01	7.41E+01	3	X	X
78875	1,2-Dichloropropane	4.37E+01	1 7.82E-02	1 8.73E-06	1 2.80E+03	3 1.15E-01	3 2.79E-03	25 3.70E+02	1 5.72E+02	1 7.59E+03	1 1.94E-05	3 4.00E-03	3 1.13E+00	4 L	5.20E+01	1.13E+02	3	X	
78933	Methyl ethyl ketone (2-but	2.30E+00	2 8.08E-02	2 9.80E-06	2 2.23E+05	3 2.29E-03	3 5.58E-05	25 352.50	4 536.78	4 7.48E+03	4 0.00E+00	3 5.00E+00	3 0.8054	4 L	9.53E+01	7.21E+01	3		
79005	1,1,2-Trichloroethane	5.01E+01	1 7.80E-02	1 8.80E-06	1 4.42E+03	3 3.73E-02	3 9.11E-04	25 3.86E+02	1 6.02E+02	1 8.32E+03	1 1.60E-05	3 1.40E-02	3 1.44E+00	4 L	2.33E+01	1.31E+02	3	X	
79016	Trichloroethylene	1.66E+02	1 7.90E-02	1 9.10E-06	1 1.47E+03	3 4.21E-01	3 1.03E-02	25 3.60E+02	1 5.44E+02	1 7.51E+03	1 1.10E-04	3 4.00E-02	3 1.46E+00	4 L	7.35E+01	1.31E+02	3	X	
79209	Methyl acetate	3.26E+00	2 1.04E-01	2 1.00E-05	2 2.00E+03	3 4.84E-03	3 1.18E-04	25 329.80	4 506.70	6 7.28E+03	6 0.00E+00	3 3.50E+00	3 0.9342	4 L	2.35E+02	7.41E+01	3		
79345	1,1,2,2-Tetrachloroethane	9.93E+01	1 7.10E-02	1 7.90E-06	1 2.96E+03	3 1.41E-02	3 3.44E-04	25 4.20E+02	1 6.61E+02	1 9.00E+03	1 5.80E-05	3 2.10E-01	3 1.60E+00	4 L	4.62E+00	1.68E+02	3	X	
79469	2-Nitropropane	1.17E+01	2 9.23E-02	2 1.01E-05	2 1.70E+04	3 5.03E-03	3 1.23E-04	25 393.20	4 594.00	8 8.38E+03	8 2.69E-03	3 2.00E-02	3 0.9876	8 L	1.80E+01	8.91E+01	3		
80626	Methylmethacrylate	6.98E+00	2 7.70E-02	2 8.60E-06	2 1.50E+04	3 1.38E-02	3 3.36E-04	25 373.50	4 567.00	6 8.97E+03	6 0.00E+00	3 7.00E-01	3 0.944	4 L	3.84E+01	1.00E+02	3		
83329	Acenaphthene	7.08E+03	1 4.21E-02	1 7.69E-06	1 3.57E+00	3 6.34E-03	3 1.55E-04	25 5.51E+02	1 8.03E+02	1 1.22E+04	1 0.00E+00	3 2.10E-01	3 NA	4 S	2.50E-03	1.54E+02	3	X	
86737	Fluorene	1.86E+04	1 3.63E-02	1 7.88E-06	1 1.98E+00	3 2.60E-03	3 6.34E-05	25 5.70E+02	1 8.70E+02	1 1.27E+04	1 0.00E+00	3 1.40E-01	3 NA	4 S	6.33E-04	1.66E+02	3	X	
87883	Hexachloro-1,3-butadiene	5.37E+04	1 5.61E-02	1 6.16E-06	1 3.20E+00	3 3.33E-01	3 8.13E-03	25 4.61E+02	1 7.38E+02	1 1.02E+04	1 2.20E-05	3 7.00E-04	3 1.56E+00	4 L	2.21E-01	2.61E+02	3	X	
88722	o-Nitrotoluene	3.24E+02	2 5.87E-02	2 8.67E-06	2 6.50E+02	3 9.11E-04	3 1.25E-05	25 495.00	4 720.00	8 1.22E+04	6 0.00E+00	3 3.50E-02	3 1.163	8 L	4.50E-02	1.37E+02	3	X	
91203	Naphthalene	1.92E+03	1 5.90E-02	1 7.50E-06	1 3.10E-01	3 1.98E-02	3 4.62E-04	25 4.91E+02	1 7.48E+02	1 1.04E+04	1 0.00E+00	3 3.00E-03	3 NA	4 S	8.50E-02	1.28E+02	3		
91576	2-Methylnaphthalene	2.81E+03	2 5.22E-02	2 7.75E-06	2 2.46E+01	3 2.12E-02	3 5.17E-04	25 514.28	4 761.00	4 1.28E+04	8 0.00E+00	3 7.00E-02	3 1.0058	4 L	5.50E+02	1.42E+02	3	X	
92524	Biphenyl	4.38E+03	2 4.04E-02	2 8.15E-06	2 7.45E+00	3 1.23E-02	3 2.99E-04	25 529.10	4 789.00	4 1.09E+04	8 0.00E+00	3 1.75E-01	3 1.04	4 S	9.64E-03	1.54E+02	3	X	
95476	o-Xylene	3.63E+02	1 8.70E-02	1 1.00E-05	1 1.78E+02	3 2.12E-01	3 5.18E-03	25 4.18E+02	1 6.30E+02	1 8.66E+03	1 0.00E+00	3 1.00E-01	3 8.80E-01	4 L	6.61E+00	1.06E+02	3		
95501	1,2-Dichlorobenzene	6.17E+02	1 6.90E-02	1 7.90E-06	1 1.56E+02	3 7.77E-02	3 1.90E-03	25 4.54E+02	1 7.05E+02	1 9.70E+03	1 0.00E+00	3 2.00E-01	3 1.31E+00	4 L	1.36E+00	1.47E+02	3		
95578	2-Chlorophenol	3.88E+02	1 5.01E-02	1 9.46E-06	1 2.20E+04	3 1.60E-02	3 3.90E-04	25 4.48E+02	1 6.75E+02	1 9.57E+03	1 0.00E+00	3 1.75E-02	3 1.26E+00	4 L	2.34E+00	1.29E+02	3	X	
95636	1,2,4-Trimethylbenzene	1.53E+03	2 6.06E-02	2 7.92E-06	2 5.70E+01	3 2.52E-01	3 6.14E-03	25 442.30	4 649.17	4 9.37E+03	6 0.00E+00	3 5.95E-03	3 1.889	4 L	2.10E+00	1.20E+02	3		
96184	1,2,3-Trichloropropane	2.20E+01	2 7.10E-02	2 7.90E-06	2 1.75E+03	3 1.67E-02	3 4.08E-04	25 430.00	4 652.00	6 9.17E+03	8 5.71E-04	3 4.90E-03	3 1.3849	4 L	3.69E+00	1.47E+02	3	X	
96333	Methyl acrylate	4.53E+00	2 9.76E-02	2 1.02E-05	2 6.00E+04	3 7.68E-03	3 1.87E-04	25 353.70	4 536.70	7 7.75E+03	7 0.00E+00	3 1.05E-01	3 0.9555	4 L	8.80E+01	8.61E+01	3	X	
97832	Ethylmethacrylate	2.95E+01	2 6.53E-02	2 8.37E-06	2 3.67E+03	3 3.44E-02	3 8.40E-04	25 390.00	4 571.00	8 1.10E+04	6 0.00E+00	3 3.15E-01	3 0.9135	4 L	2.06E+01	1.14E+02	3		
98066	tert-Butylbenzene	7.71E+02	2 5.65E-02	2 8.02E-06	2 2.95E+01	3 4.87E-01	3 1.19E-02	25 442.10	4 1220.00	9 8.98E+03	8 0.00E+00	3 1.40E-01	3 0.8665	4 L	2.20E+00	1.34E+02	3	X	
98828	Cumene	4.89E+02	2 6.50E-02	2 7.10E-06	2 6.13E+01	3 4.74E+01	3 1.46E-02	25 425.56	4 631.10	4 1.03E+04	6 0.00E+00	3 4.00E-01	3 0.8618	4 L	4.50E+00	1.20E+02	3		
98862	Acetophenone	5.77E+01	2 6.00E-02	2 8.73E-06	2 6.13E+03	3 4.38E-04	3 1.07E-05	25 475.00	4 709.50	4 1.17E+04	6 0.00E+00	3 3.50E-01	3 1.0281	4 S,L	3.97E-01	1.20E+02	3	X	
98953	Nitrobenzene	6.46E+01	1 7.60E-02	1 8.60E-06	1 2.09E+03	3 9.82E-04	3 2.39E-05	25 4.84E+02	1 7.19E+02	1 1.06E+04	1 0.00E+00	3 2.00E-03	3 1.20E+00	4 L	2.45E-01	1.23E+02	3		
100414	Ethylbenzene																		

CAS No.	Chemical	Organic Carbon Partition Coefficient K _{oc} (cm ³ /g)	Diffusivity in Air D _a (cm ² /s)	Diffusivity in Water D _w (cm ² /s)	Pure Component Water Solubility S (mg/L)	Henry's Law Constant H ¹ (unitless)	Henry's Law Constant at Reference Temperature H (atm·m ³ /mol)	Henry's Law Constant Reference Temperature T _R (°C)	Normal Boiling Point T _B (°K)	Critical Temperature T _C (°K)	Enthalpy of Vaporization at the Normal Boiling Point deltaH _{v,b} (cal/mol)	Unit Risk Factor URF (ug/m ³) ⁻¹	Reference Concentration RIC (mg/m ³)	Density, r _l (g/cm ³)	Physical State at soil Temp (S,L,G)	Vapor Pressure VP (mm Hg)	Molecular Weight Mw (g/mole)	URF extrapolated (X)	Rfc extrapolated (X)												
135988	sec-Butylbenzene	9.66E+02	2	5.70E-02	2	8.12E-06	2	3.94E+00	3	5.68E-01	3	1.39E-02	25	446.50	4	679.00	9	8.87E+04	8	0.00E+00	3	1.40E-01	3	0.8621	8	L	3.10E-01	1.34E+02	3		X
141786	Ethylacetate	6.44E+00	2	7.32E-02	2	9.70E-06	2	8.03E+04	3	5.64E-03	3	1.38E-04	25	350.26	4	523.30	4	7.63E+03	4	0.00E+00	3	3.15E+00	3	0.9003	4	L	9.37E+01	8.81E+01	3		X
156592	cis-1,2-Dichloroethylene	3.55E+01	1	7.36E-02	1	1.13E-05	1	3.50E+03	3	1.67E-01	3	4.07E-03	25	3.34E+02	1	5.44E+02	1	7.19E+03	1	0.00E+00	3	3.50E-02	3	1.28E+00	4	L	2.03E+02	9.89E+01	3		X
156605	trans-1,2-Dichloroethylene	5.25E+01	1	7.07E-02	1	1.19E-05	1	6.30E+03	3	3.84E-01	3	9.36E-03	25	3.21E+02	1	5.17E+02	1	6.72E+03	1	0.00E+00	3	7.00E-02	3	1.26E+00	4	L	3.33E+02	9.89E+01	3		X
205992	Benzo(b)fluoranthene	1.23E+06	1	2.26E-02	1	5.56E-06	1	1.50E-03	3	4.54E-03	3	1.11E-04	25	7.16E+02	1	9.69E+02	1	1.70E+04	1	2.09E-04	3	0.00E+00	3	NA	4	S	5.00E-07	2.52E+02	3	X	
218019	Chrysene	3.98E+05	1	2.48E-02	1	6.21E-06	1	6.30E-03	3	3.87E-03	3	9.44E-05	25	7.14E+02	1	9.79E+02	1	1.65E+04	1	2.09E-06	3	0.00E+00	3	NA	4	S	6.23E-09	2.28E+02	3	X	
309002	Aldrin	2.45E+06	1	1.32E-02	1	4.86E-06	1	1.70E-02	3	6.95E-03	3	1.70E-04	25	6.03E+02	1	8.39E+02	1	1.50E+04	1	4.90E-03	3	1.05E-04	3	NA	4	S	6.00E-06	3.65E+02	3		X
319846	alpha-HCH (alpha-BHC)	1.23E+03	1	1.42E-02	1	7.34E-06	1	2.00E+00	3	4.34E-04	3	1.06E-05	25	5.97E+02	1	8.39E+02	1	1.50E+04	1	1.80E-03	3	0.00E+00	3	NA	4	S	4.50E-05	2.91E+02	3		
541731	1,3-Dichlorobenzene	1.98E+03	2	6.92E-02	2	7.86E-06	2	1.34E+02	3	1.27E-01	3	3.09E-03	25	446.00	4	684.00	8	9.23E+03	4	0.00E+00	3	1.05E-01	3	1.2884	4	L	2.15E+00	1.47E+02	3		X
542756	1,3-Dichloropropene	4.57E+01	1	6.26E-02	1	1.00E-05	1	2.80E+03	3	7.24E-01	3	1.77E-02	25	3.61E+02	1	5.67E+02	1	7.90E+03	1	4.00E-06	3	2.00E-02	3	1.22E+00	4	L	3.40E+01	1.11E+02	3		
630206	1,1,1,2-Tetrachloroethane	1.18E+02	2	7.10E-02	2	7.90E-06	2	1.10E+03	3	9.90E-02	3	2.41E-03	25	4.04E+02	4	6.24E+02	6	9.77E+03	6	7.40E-06	3	1.05E-01	3	1.54E+00	4	L	1.20E+01	1.68E+02	3		X
163404	MTBE	7.26E+00	2	1.02E-01	2	1.05E-05	2	5.10E+04	3	2.56E-02	3	6.23E-04	25	328.30	4	497.10	4	6.68E+03	4	0.00E+00	3	3.00E+00	3	0.7405	4	L	2.50E+02	8.82E+01	3		
7439976	Mercury (elemental)	5.20E+01	1	3.07E-02	1	6.30E-06	1	2.00E+01	3	4.40E-01	3	1.07E-02	25	6.30E+02	1	1.75E+03	1	1.41E+04	1	0.00E+00	3	3.00E-04	3	1.35E+01	4	L	2.00E-03	2.01E+02	3		

Sources:

- 1 User's Guide for the Johnson and Ettinger (1991) Model for Subsurface Vapor Intrusion Into Buildings (Revised), December, 2000
- 2 Water9 Database
- 3 VI Draft Guidance, November 2002
- 4 CRC Handbook of Chemistry and Physics, 76th Edition
- 5 The Merck Index, 10th Edition
- 6 Hazardous Substances Data Bank, February 2003
<http://toxnet.nlm.nih.gov/cgi-bin/sis/htmlgen?HSDB>
- 7 Weiss, G., Hazardous Chemicals Data Book, Second Edition. Noyes Data Corporation, 1986.
- 8 DECEMA Web Database, March 2003
<http://l-systems.dechema.de/>
- 9 Flexware Engineering Solutions for Industry, Properties of Various Gases
www.flexwareinc.com/gasprop.htm

* For enthalpy of vaporization, highlighted values are enthalpy of vaporization at value other than normal boiling point.
For density, highlighted values are taken at temperature other than 20°C.

APPENDIX C

**EXAMPLE WORKSHEETS FOR THE ADVANCED SOIL
CONTAMINATION MODEL**

DATA ENTRY SHEET

SL-ADV
Version 3.1; 02/04

CALCULATE RISK-BASED SOIL CONCENTRATION (enter "X" in "YES" box)

YES

OR

CALCULATE INCREMENTAL RISKS FROM ACTUAL SOIL CONCENTRATION (enter "X" in "YES" box and initial soil conc. below)

YES

Reset to Defaults

ENTER Chemical CAS No. (numbers only, no dashes)	ENTER Initial soil conc., C_R ($\mu\text{g}/\text{kg}$)	ENTER Chemical
71432		Benzene

MORE
↓

ENTER Average soil temperature, T_S ($^{\circ}\text{C}$)	ENTER Depth below grade to bottom of enclosed space floor, L_F (cm)	ENTER Depth below grade to top of contamination, L_t (cm)	ENTER Depth below grade to bottom of contamination, (enter value of 0 if value is unknown) L_b (cm)	ENTER Totals must add up to value of L_t (cell G28)			ENTER Soil stratum A SCS soil type (used to estimate soil vapor permeability)	ENTER User-defined stratum A soil vapor permeability, k_v (cm^2)
h_A (cm)	h_B (cm)	h_C (cm)		Thickness of soil stratum A, h_A (cm)	Thickness of soil stratum B, (Enter value or 0) h_B (cm)	Thickness of soil stratum C, (Enter value or 0) h_C (cm)	OR	
10	200	400	600	200	100	100	L	

MORE
↓

ENTER Stratum A SCS soil type Lookup Soil Parameters	ENTER Stratum A soil dry bulk density, ρ_b^A (g/cm^3)	ENTER Stratum A soil total porosity, n^A (unitless)	ENTER Stratum A soil water-filled porosity, θ_w^A (cm^3/cm^3)	ENTER Stratum A soil organic carbon fraction, f_{oc}^A (unitless)	ENTER Stratum B SCS soil type Lookup Soil Parameters	ENTER Stratum B soil dry bulk density, ρ_b^B (g/cm^3)	ENTER Stratum B soil total porosity, n^B (unitless)	ENTER Stratum B soil water-filled porosity, θ_w^B (cm^3/cm^3)	ENTER Stratum B soil organic carbon fraction, f_{oc}^B (unitless)	ENTER Stratum C SCS soil type Lookup Soil Parameters	ENTER Stratum C soil dry bulk density, ρ_b^C (g/cm^3)	ENTER Stratum C soil total porosity, n^C (unitless)	ENTER Stratum C soil water-filled porosity, θ_w^C (cm^3/cm^3)	ENTER Stratum C soil organic carbon fraction, f_{oc}^C (unitless)
L	1.59	0.399	0.148	0.002	L	1.59	0.399	0.148	0.002	S	1.66	0.375	0.054	0.002

MORE
↓

ENTER Enclosed space floor thickness, L_{crack} (cm)	ENTER Soil-bldg. pressure differential, ΔP ($\text{g}/\text{cm}\cdot\text{s}^2$)	ENTER Enclosed space floor length, L_B (cm)	ENTER Enclosed space floor width, W_B (cm)	ENTER Enclosed space height, H_B (cm)	ENTER Floor-wall seam crack width, w (cm)	ENTER Indoor air exchange rate, ER (1/h)	ENTER Average vapor flow rate into bldg. OR Leave blank to calculate Q_{soil} (L/m)
10	40	1000	1000	366	0.1	0.25	5

ENTER Averaging time for carcinogens, AT_C (yrs)	ENTER Averaging time for noncarcinogens, AT_{NC} (yrs)	ENTER Exposure duration, ED (yrs)	ENTER Exposure frequency, EF (days/yr)	ENTER Target risk for carcinogens, TR (unitless)	ENTER Target hazard quotient for noncarcinogens, THQ (unitless)
70	30	30	350	1.0E-06	1
Used to calculate risk-based soil concentration.					

END

CHEMICAL PROPERTIES SHEET

Diffusivity in air, D_a (cm^2/s)	Diffusivity in water, D_w (cm^2/s)	Henry's law constant at reference temperature, H ($\text{atm}\cdot\text{m}^3/\text{mol}$)	Henry's law constant reference temperature, T_R ($^\circ\text{C}$)	Enthalpy of vaporization at the normal boiling point, $\Delta H_{v,b}$ (cal/mol)	Normal boiling point, T_B ($^\circ\text{K}$)	Critical temperature, T_C ($^\circ\text{K}$)	Organic carbon partition coefficient, K_{oc} (cm^3/g)	Pure component water solubility, S (mg/L)	Unit risk factor, URF ($\mu\text{g}/\text{m}^3$) ⁻¹	Reference conc., RfC (mg/m^3)	Physical state at soil temperature, (S,L,G)
8.80E-02	9.80E-06	5.54E-03	25	7,342	353.24	562.16	5.89E+01	1.79E+03	7.8E-06	3.0E-02	L

END

INTERMEDIATE CALCULATIONS SHEET

Exposure duration, τ (sec)	Source-building separation, L_T (cm)	Stratum A soil air-filled porosity, θ_a^A (cm^3/cm^3)	Stratum B soil air-filled porosity, θ_a^B (cm^3/cm^3)	Stratum C soil air-filled porosity, θ_a^C (cm^3/cm^3)	Stratum A effective total fluid saturation, S_{se} (cm^3/cm^3)	Stratum A soil intrinsic permeability, k_i (cm^2)	Stratum A soil relative air permeability, k_{rg} (cm^2)	Stratum A soil effective vapor permeability, k_v (cm^2)	Floor-wall seam perimeter, X_{crack} (cm)	Initial soil concentration used, C_R ($\mu\text{g}/\text{kg}$)	Bldg. ventilation rate, $Q_{building}$ (cm^3/s)
9.46E+08	200	0.251	0.251	0.321	0.257	1.85E-09	0.854	1.58E-09	4,000	1.00E+00	2.54E+04

Area of enclosed space below grade, A_B (cm^2)	Crack-to-total area ratio, η (unitless)	Crack depth below grade, Z_{crack} (cm)	Enthalpy of vaporization at ave. soil temperature, $\Delta H_{v,TS}$ (cal/mol)	Henry's law constant at ave. soil temperature, H_{TS} (atm- m^3/mol)	Henry's law constant at ave. soil temperature, H'_{TS} (unitless)	Vapor viscosity at ave. soil temperature, μ_{TS} (g/cm-s)	Stratum A effective diffusion coefficient, D_{eff}^A (cm^2/s)	Stratum B effective diffusion coefficient, D_{eff}^B (cm^2/s)	Stratum C effective diffusion coefficient, D_{eff}^C (cm^2/s)	Total overall effective diffusion coefficient, D_{eff}^T (cm^2/s)	Diffusion path length, L_d (cm)	Convection path length, L_p (cm)
1.80E+06	2.22E-04	200	8,122	2.68E-03	1.15E-01	1.75E-04	5.54E-03	5.54E-03	1.42E-02	7.97E-03	200	200

Soil-water partition coefficient, K_d (cm^3/g)	Source vapor conc., C_{source} ($\mu\text{g}/\text{m}^3$)	Crack radius, r_{crack} (cm)	Average vapor flow rate into bldg., Q_{soil} (cm^3/s)	Crack effective diffusion coefficient, D^{crack} (cm^2/s)	Area of crack, A_{crack} (cm^2)	Exponent of equivalent foundation Peclet number, $\exp(Pe^f)$ (unitless)	Infinite source indoor attenuation coefficient, α (unitless)	Infinite source bldg. conc., $C_{building}$ ($\mu\text{g}/\text{m}^3$)	Finite source β term (unitless)	Finite source ψ term (sec^{-1})	Time for source depletion, τ_D (sec)	Exposure duration > time for source depletion (YES/NO)
1.18E-01	6.68E+02	0.10	8.33E+01	5.54E-03	4.00E+02	2.06E+163	NA	NA	1.86E+00	8.02E-08	2.94E+07	YES

Finite indoor attenuation coefficient, $\langle \alpha \rangle$ (unitless)	Mass limit bldg. conc., $C_{building}$ ($\mu\text{g}/\text{m}^3$)	Finite source bldg. conc., $C_{building}$ ($\mu\text{g}/\text{m}^3$)	Final finite source bldg. conc., $C_{building}$ ($\mu\text{g}/\text{m}^3$)	Unit risk factor, URF ($\mu\text{g}/\text{m}^3$) $^{-1}$	Reference conc., RfC (mg/m^3)
NA	2.49E-02	NA	2.49E-02	7.8E-06	3.0E-02

END

RESULTS SHEET

RISK-BASED SOIL CONCENTRATION CALCULATIONS:

Indoor exposure soil conc., carcinogen (µg/kg)	Indoor exposure soil conc., noncarcinogen (µg/kg)	Risk-based indoor exposure soil conc., (µg/kg)	Soil saturation conc., C _{sat} (µg/kg)	Final indoor exposure soil conc., (µg/kg)
1.26E+01	1.26E+03	1.26E+01	3.09E+05	1.26E+01

INCREMENTAL RISK CALCULATIONS:

Incremental risk from vapor intrusion to indoor air, carcinogen (unitless)	Hazard quotient from vapor intrusion to indoor air, noncarcinogen (unitless)
NA	NA

MESSAGE AND ERROR SUMMARY BELOW: (DO NOT USE RESULTS IF ERRORS ARE PRESENT)

MESSAGE: The values of C_{source} and C_{building} on the INTERCALCS worksheet are based on unity and do not represent actual values.

SCROLL
DOWN
TO "END"

END

VLOOKUP TABLES

SCS Soil Type	Soil Properties Lookup Table							Bulk Density			
	K _s (cm/h)	α _i (1/cm)	N (unitless)	M (unitless)	n (cm ³ /cm ³)	θ _i (cm ³ /cm ³)	Mean Grain Diameter (cm)	(g/cm ³)	θ _w (cm ³ /cm ³)	SCS Soil Name	
C	0.61	0.01496	1.253	0.2019	0.459	0.098	0.0092	1.43	0.215	Clay	
CL	0.34	0.01581	1.416	0.2938	0.442	0.079	0.016	1.48	0.168	Clay Loam	
L	0.50	0.01112	1.472	0.3207	0.399	0.061	0.020	1.59	0.148	Loam	
LS	4.38	0.03475	1.746	0.4273	0.390	0.049	0.040	1.62	0.076	Loamy Sand	
S	26.78	0.03524	3.177	0.6852	0.375	0.053	0.044	1.66	0.054	Sand	
SC	0.47	0.03342	1.208	0.1722	0.385	0.117	0.025	1.63	0.197	Sandy Clay	
SCL	0.55	0.02109	1.330	0.2481	0.384	0.063	0.029	1.63	0.146	Sandy Clay Loam	
SI	1.82	0.00658	1.679	0.4044	0.489	0.050	0.0046	1.35	0.167	Silt	
SIC	0.40	0.01622	1.321	0.2430	0.481	0.111	0.0039	1.38	0.216	Silty Clay	
SICL	0.46	0.00839	1.521	0.3425	0.482	0.090	0.0056	1.37	0.198	Silty Clay Loam	
SIL	0.76	0.00506	1.663	0.3987	0.439	0.065	0.011	1.49	0.180	Silt Loam	
SL	1.60	0.02667	1.449	0.3099	0.387	0.039	0.030	1.62	0.103	Sandy Loam	

CAS No.	Chemical	Chemical Properties Lookup Table												URF	RfC	
		Organic carbon partition coefficient, K _{oc} (cm ³ /g)	Diffusivity in air, D _a (cm ² /s)	Diffusivity in water, D _w (cm ² /s)	Pure component water solubility, S (mg/L)	Henry's law constant H' (unitless)	Henry's law constant at reference temperature, H (atm-m ³ /mol)	Henry's law constant reference temperature, T _R (°C)	Normal boiling point, T _B (°K)	Critical temperature, T _C (°K)	Enthalpy of vaporization at the normal boiling point, ΔH _{v,b} (cal/mol)	Unit risk factor, URF (μg/m ³) ⁻¹	Reference conc., RfC (mg/m ³)			Physical state at soil temperature, (S,L,G)
56235	Carbon tetrachloride	1.74E+02	7.80E-02	8.80E-06	7.93E+02	1.24E+00	3.03E-02	25	349.90	556.60	7,127	1.5E-05	0.0E+00	L		
57749	Chlordane	1.20E+05	1.18E-02	4.37E-06	5.60E-02	1.99E-03	4.85E-05	25	624.24	885.73	14,000	1.0E-04	7.0E-04	S		
58899	gamma-HCH (Lindane)	1.07E+03	1.42E-02	7.34E-06	7.30E+00	5.73E-04	1.40E-05	25	596.55	839.36	15,000	3.7E-04	1.1E-03	S	X	X
60297	Ethyl ether	5.73E+00	7.82E-02	8.61E-06	5.68E+04	1.35E+00	3.29E-02	25	307.50	466.74	6,338	0.0E+00	7.0E-01	L	X	X
60571	Dieldrin	2.14E+04	1.25E-02	4.74E-06	1.95E-04	6.18E-04	1.51E-05	25	613.32	842.25	17,000	4.6E-03	1.8E-04	S	X	X
67641	Acetone	5.75E-01	1.24E-01	1.14E-05	1.00E+06	1.59E-03	3.87E-05	25	329.20	508.10	6,955	0.3E+00	3.5E-01	L		X
67663	Chloroform	3.98E+01	1.04E-01	1.00E-05	7.92E+03	1.50E-01	3.66E-03	25	334.32	536.40	6,988	2.0E+00	0.0E+00	L		
67721	Hexachloroethane	1.78E+03	2.50E-03	6.80E-06	5.00E+01	1.59E-01	3.88E-03	25	458.00	695.00	9,510	4.0E-06	3.5E-03	S		X
71432	Benzene	5.89E+01	8.80E-02	9.80E-06	1.79E+03	2.27E-01	5.54E-03	25	353.24	562.16	7,342	7.8E-06	3.0E-02	L		
71556	1,1,1-Trichloroethane	1.10E+02	7.80E-02	8.80E-06	1.33E+03	7.03E-01	1.72E-02	25	347.24	545.00	7,136	0.0E+00	2.2E+00	L		
72435	Methoxychlor	9.77E+04	1.56E-02	4.46E-06	1.00E-01	6.46E-04	1.58E-05	25	651.02	848.49	16,000	0.0E+00	1.8E-02	S		X
72559	DDE	4.47E+06	1.44E-02	5.87E-06	1.20E-01	8.59E-04	2.09E-05	25	636.44	860.38	15,000	9.7E-05	0.0E+00	S	X	
74839	Methyl bromide	1.05E+01	7.28E-02	1.21E-05	1.52E+04	2.55E-01	6.22E-03	25	276.71	467.00	5,714	0.0E+00	5.0E-03	G		
74873	Methyl chloride (chloromethane)	2.12E+00	1.26E-01	6.50E-06	5.33E+03	3.61E-01	8.80E-03	25	249.00	416.25	5,115	1.0E-06	9.0E-02	L		
74908	Hydrogen cyanide	3.80E+00	1.93E-01	2.10E-05	1.00E+06	5.44E-03	1.33E-04	25	299.00	456.70	6,676	0.0E+00	3.0E-03	L		
74953	Methylene bromide	1.26E+01	4.30E-02	8.44E-06	1.19E+04	3.52E-02	8.59E-04	25	370.00	583.00	7,868	0.0E+00	3.5E-02	L		X
75003	Chloroethane (ethyl chloride)	4.40E+00	2.71E-01	1.15E-05	5.68E+03	3.61E-01	8.80E-03	25	285.30	460.40	5,879	8.3E-07	1.0E+01	L	X	
75014	Vinyl chloride (chloroethene)	1.86E+01	1.06E-01	1.23E-05	8.80E+03	1.10E+00	2.69E-02	25	259.25	432.00	5,250	8.8E-06	1.0E-01	G		
75058	Acetonitrile	4.20E+00	1.28E-01	1.66E-05	1.00E+06	1.42E-03	3.45E-05	25	354.60	545.50	7,110	0.0E+00	6.0E-02	L		
75070	Acetaldehyde	1.06E+00	1.24E-01	1.41E-05	1.00E+06	3.23E-03	7.87E-05	25	293.10	466.00	6,157	2.2E-06	9.0E-03	L		
75092	Methylene chloride	1.17E+01	1.01E-01	1.17E-05	1.30E+04	8.96E-02	2.18E-03	25	313.00	510.00	6,706	4.7E-07	3.0E+00	L		
75150	Carbon disulfide	4.57E+01	1.04E-01	1.00E-05	1.19E+03	1.24E+00	3.02E-02	25	319.00	552.00	6,391	0.0E+00	7.0E-01	L		
75218	Ethylene oxide	1.33E+00	1.04E-01	1.45E-05	3.04E+05	2.27E-02	5.54E-04	25	283.60	469.00	6,104	1.0E-04	0.0E+00	L		
75252	Bromoform	8.71E+01	1.49E-02	1.03E-05	3.10E+03	2.41E-02	5.88E-04	25	422.35	696.00	9,479	1.1E-06	7.0E-02	L		X
75274	Bromodichloromethane	5.50E+01	2.98E-02	1.06E-05	6.74E+03	6.54E-02	1.60E-03	25	363.15	585.85	7,800	1.8E-05	7.0E-02	L	X	X
75296	2-Chloropropane	9.14E+00	8.88E-02	1.01E-05	3.73E+03	5.93E-01	1.45E-02	25	308.70	485.00	6,286	0.0E+00	1.0E-01	L		
75343	1,1-Dichloroethane	3.16E+01	7.42E-02	1.05E-05	5.06E+03	2.30E-01	5.61E-03	25	330.55	523.00	6,895	0.0E+00	5.0E-01	L		
75354	1,1-Dichloroethylene	5.89E+01	9.00E-02	1.04E-05	2.25E+03	1.07E+00	2.60E-02	25	304.75	576.05	6,247	0.0E+00	2.0E-01	L		
75456	Chlorodifluoromethane	4.79E+01	1.01E-01	1.28E-05	2.00E+00	1.10E+00	2.70E-02	25	232.40	369.30	4,836	0.0E+00	5.0E+01	L		
75694	Trichlorofluoromethane	4.97E+02	8.70E-02	9.70E-06	1.10E+03	3.97E+00	9.68E-02	25	296.70	471.00	5,999	0.0E+00	7.0E-01	L		
75718	Dichlorodifluoromethane	4.57E+02	6.65E-02	9.92E-06	2.80E+02	1.40E+01	3.42E-01	25	243.20	384.95	9,421	0.0E+00	2.0E-01	L		
76131	1,1,2-Trichloro-1,2,2-trifluoroethane	1.11E+04	7.80E-02	8.20E-06	1.70E+02	1.97E+01	4.80E-01	25	320.70	487.30	6,463	0.0E+00	3.0E+01	L		
76448	Heptachlor	1.41E+06	1.12E-02	5.69E-06	1.80E-01	6.05E+01	1.48E+00	25	603.69	846.31	13,000	1.3E-03	1.8E-03	S		X
77474	Hexachlorocyclopentadiene	2.00E+05	1.61E-02	7.21E-06	1.80E+00	1.10E+00	2.69E-02	25	512.15	746.00	10,931	0.0E+00	2.0E-04	L		
78331	Isobutanol	2.59E+00	8.60E-02	9.30E-06	8.50E+04	4.83E-04	1.18E-05	25	381.04	547.78	10,936	0.0E+00	1.1E+00	L		X
78875	1,2-Dichloropropane	4.37E+01	7.82E-02	8.73E-06	2.80E+03	1.15E-01	2.79E-03	25	369.52	572.00	7,590	1.9E-05	4.0E-03	L	X	
78933	Methylethylketone (2-butanone)	2.30E+00	8.08E-02	9.80E-06	2.23E+05	2.29E-03	5.58E-05	25	352.50	536.78	7,481	0.0E+00	5.0E+00	L		
79005	1,1,2-Trichloroethane	5.01E+01	7.80E-02	8.80E-06	4.42E+03	3.73E-02	9.11E-04	25	386.15	602.00	8,322	1.6E-05	1.4E-02	L		X
79016	Trichloroethylene	1.66E+02	7.90E-02	9.10E-06	1.47E+03	4.21E-01	1.03E-02	25	360.36	544.20	7,505	1.1E-04	4.0E-02	L	X	
79209	Methyl acetate	3.26E+00	1.04E-01	1.00E-05	2.00E+03	4.84E-03	1.18E-04	25	329.80	506.70	7,260	0.0E+00	3.5E+00	L		X
79345	1,1,2,2-Tetrachloroethane	9.33E+01	7.10E-02	7.90E-06	2.96E+03	1.41E-02	3.44E-04	25	419.60	661.15	8,996	5.8E-05	2.1E-01	L		X
79469	2-Nitropropane	1.17E+01	9.23E-02	1.01E-05	1.70E+04	5.03E-03	1.23E-04	25	393.20	594.00	8,383	2.7E-03	2.0E-02	L		
80626	Methylmethacrylate	6.98E+00	7.70E-02	8.60E-06	1.50E+04	1.38E-02	3.36E-04	25	373.50	567.00	8,975	0.0E+00	7.0E-01	L		
83329	Acenaphthene	7.08E+03	4.21E-02	7.69E-06	3.57E+00	6.34E-03	1.55E-04	25	550.54	803.15	12,155	0.0E+00	2.1E-01	S		X
86737	Fluorene	1.38E+04	3.63E-02	7.88E-06	1.98E+00	2.60E-03	6.34E-05	25	570.44	870.00	12,666	0.0E+00	1.4E-01	S		X
87683	Hexachloro-1,3-butadiene	5.37E+04	5.61E-02	6.16E-06	3.20E+00	3.33E-01	8.13E-03	25	486.15	738.00	10,206	2.2E-05	7.0E-04	L		X
88722	o-Nitrotoluene	3.24E+02	5.87E-02	8.67E-06	6.50E+02	5.11E-04	1.25E-05	25	495.00	720.00	12,239	0.0E+00	3.5E-02	L		X
91203	Naphthalene	2.00E+03	5.90E-02	7.50E-06	3.10E+01	1.98E-02	4.82E-04	25	491.14	748.40	10,373	0.0E+00	3.0E-03	S		
91576	2-Methylnaphthalene	2.81E+03	5.22E-02	7.75E-06	2.46E+01	2.12E-02	5.17E-04	25	514.26	761.00	12,600	0.0E+00	7.0E-02	S		X
92524	Biphenyl	4.38E+03	4.04E-02	8.15E-06	7.45E+00	1.23E-02	2.99E-04	25	529.10	789.00	10,890	0.0E+00	1.8E-01	S		X
95476	o-Xylene	3.63E+02	8.70E-02	1.00E-05	1.78E+02	2.12E-01	5.18E-03	25	417.60	630.30	8,661	0.0E+00	1.0E-01	L		X
95501	1,2-Dichlorobenzene	6.17E+02	6.90E-02	7.90E-06	1.56E+02	1.77E-02	1.90E-03	25	453.57	705.00	9,700	0.0E+00	2.0E-01	L		
95578	2-Chlorophenol	3.88E+02	5.01E-02	9.46E-06	2.20E+04	1.60E-02	3.90E-04	25	447.53	675.00	9,572	0.0E+00	1.8E-02	L		X
95636	1,2,4-Trimethylbenzene	1.35E+03	6.06E-02	7.92E-06	5.70E+01	2.52E-01	6.14E-03	25	442.30	649.17	9,369	0.0E+00	6.0E-03	L		

VLOOKUP TABLES

96184	1,2,3-Trichloropropane	2.20E+01	7.10E-02	7.90E-06	1.75E+03	1.67E-02	25	430.00	652.00	9,171	5.7E-04	4.9E-03	L	X	
96333	Methyl acrylate	4.53E+00	9.76E-02	1.02E-05	6.00E+04	7.68E-03	25	353.70	536.00	7,749	0.0E+00	1.1E-01	L		X
97632	Ethylmethacrylate	2.95E+01	6.53E-02	8.37E-06	3.67E+03	3.44E-02	25	390.00	571.00	10,957	0.0E+00	3.2E-01	L		X
98066	tert-Butylbenzene	7.71E+02	5.65E-02	8.02E-06	2.95E+01	4.87E-01	25	442.10	1220.00	8,980	0.0E+00	1.4E-01	L		X
98828	Cumene	4.89E+02	6.50E-02	7.10E-06	6.13E+01	4.74E+01	25	425.56	631.10	10,335	0.0E+00	4.0E-01	L		
98862	Acetophenone	5.77E+01	6.00E-02	8.73E-06	6.13E+03	4.38E-04	25	475.00	709.50	11,732	0.0E+00	3.5E-01	S,L		X
98953	Nitrobenzene	6.46E+01	7.60E-02	8.60E-06	2.09E+03	9.82E-04	25	483.95	719.00	10,566	0.0E+00	2.0E-03	L		
100414	Ethylbenzene	3.63E+02	7.50E-02	7.80E-06	1.69E+02	3.22E-01	25	409.34	617.20	8,501	0.0E+00	1.0E+00	L		
100425	Styrene	7.76E+02	7.10E-02	8.00E-06	3.10E+02	1.12E-01	25	418.31	636.00	8,737	0.0E+00	1.0E+00	L		
100447	Benzylchloride	6.14E+01	7.50E-02	7.80E-06	5.25E+02	1.70E-02	25	452.00	685.00	8,773	4.9E-05	0.0E+00	L	X	
100527	Benzaldehyde	4.59E+01	7.21E-02	9.07E-06	3.30E+03	9.73E-04	25	452.00	695.00	11,658	0.0E+00	3.5E-01	L		X
103651	n-Propylbenzene	5.62E+02	6.01E-02	7.83E-06	6.00E+01	4.37E-01	25	432.20	630.00	9,123	0.0E+00	1.4E-01	L		X
104518	n-Butylbenzene	1.11E+03	5.70E-02	8.12E-06	2.00E+00	5.38E-01	25	456.46	660.50	9,290	0.0E+00	1.4E-01	L		X
106423	p-Xylene	3.89E+02	7.69E-02	8.44E-06	1.85E+02	3.13E-01	25	411.52	616.20	8,525	0.0E+00	1.0E-01	L		X
106467	1,4-Dichlorobenzene	6.17E+02	6.90E-02	7.90E-06	7.90E+01	9.82E-02	25	447.21	684.75	9,271	0.0E+00	8.0E-01	S		
106934	1,2-Dibromoethane (ethylene dibr	2.50E+01	2.17E-02	1.19E-05	4.18E+03	3.04E-02	25	404.60	583.00	8,310	2.2E-04	2.0E-04	L		
106990	1,3-Butadiene	1.91E+01	2.49E-01	1.08E-05	7.35E+02	3.01E+00	25	268.60	425.00	5,370	3.0E-02	2.0E-03	L		
107028	Acrolein	2.76E+00	1.05E-01	1.22E-05	2.13E+05	4.99E-03	25	325.60	506.00	6,731	0.0E+00	2.0E-05	L		
107062	1,2-Dichloroethane	1.74E+01	1.04E-01	9.90E-06	8.52E+03	4.00E-02	25	356.65	561.00	7,643	2.6E-05	0.0E+00	L		
107131	Acrylonitrile	5.90E+00	1.22E-01	1.34E-05	7.40E+04	4.21E-03	25	350.30	519.00	7,786	6.8E-05	2.0E-03	L		
108054	Vinyl acetate	5.25E+00	8.50E-02	9.20E-06	2.00E+04	2.09E-02	25	345.65	519.13	7,800	0.0E+00	2.0E-01	L		
108101	Methylisobutylketone (4-methyl-2-	9.06E+00	7.50E-02	7.80E-06	1.90E+04	5.64E-03	25	389.50	571.00	8,243	0.0E+00	3.0E+00	L		
108383	m-Xylene	4.07E+02	7.00E-02	7.80E-06	1.61E+02	3.00E-01	25	412.27	617.05	8,523	0.0E+00	1.0E-01	L		X
108678	1,3,5-Trimethylbenzene	1.35E+03	6.02E-02	8.67E-06	2.00E+00	2.41E-01	25	437.89	637.25	9,321	0.0E+00	6.0E-03	L		
108872	Methylcyclohexane	7.85E+01	7.35E-02	8.52E-06	1.40E+01	4.22E+00	25	373.90	572.20	7,474	0.0E+00	3.0E+00	L		
108883	Toluene	1.82E+02	8.70E-02	8.60E-06	5.26E+02	2.72E-01	25	383.78	591.79	7,930	0.0E+00	4.0E-01	L		
108907	Chlorobenzene	2.19E+02	7.30E-02	8.70E-06	4.72E+02	1.51E-01	25	404.87	632.40	8,410	0.0E+00	6.0E-02	L		
109693	1-Chlorobutane	1.72E+01	8.26E-02	1.00E-05	1.10E+03	6.93E-01	25	351.60	542.00	7,263	0.0E+00	1.4E+00	L		X
110009	Furan	1.86E+01	1.04E-01	1.22E-05	1.00E+04	2.21E-01	25	304.60	490.20	6,477	0.0E+00	3.5E-03	L		X
110543	Hexane	4.34E+01	2.00E-01	7.77E-06	1.24E+01	6.82E+01	25	341.70	508.00	6,895	0.0E+00	2.0E-01	L		
111444	Bis(2-chloroethyl)ether	1.55E+01	6.92E-02	7.53E-06	1.72E+04	7.36E-04	25	451.15	659.79	10,803	3.3E-04	0.0E+00	L		
115297	Endosulfan	2.14E+03	1.15E-02	4.55E-06	5.10E-01	4.58E-04	25	674.43	942.94	14,000	0.0E+00	2.1E-02	S		X
118741	Hexachlorobenzene	5.50E+04	5.42E-02	5.91E-06	5.00E-03	5.40E-02	25	582.55	825.00	14,447	4.6E-04	2.8E-03	S		X
120821	1,2,4-Trichlorobenzene	1.78E+03	3.00E-02	8.23E-06	4.88E+01	5.81E-02	25	486.15	725.00	10,471	0.0E+00	4.0E-03	L		
123739	Crotonaldehyde (2-butenal)	4.82E+00	9.56E-02	1.07E-05	3.69E+04	7.99E-04	25	375.20	568.00	9	5.4E-04	0.0E+00	L	X	
124481	Chlorodibromomethane	6.31E+01	1.96E-02	1.05E-05	2.60E+03	3.20E-02	25	416.14	678.20	5,900	2.4E-05	7.0E-02	L	X	X
126987	Methacrylonitrile	3.58E+01	1.12E-01	1.32E-05	2.54E+04	1.01E-02	25	363.30	554.00	7,600	0.0E+00	7.0E-04	L		
126998	2-Chloro-1,3-butadiene (chloropr	6.73E+01	8.58E-02	1.03E-05	2.12E+03	4.91E-01	25	332.40	525.00	8,075	0.0E+00	7.0E-03	L		
127184	Tetrachloroethylene	1.55E+02	7.20E-02	8.20E-06	2.00E+02	7.53E-01	25	394.40	620.20	8,288	5.9E-06	6.0E-01	S		
129000	Pyrene	1.05E+05	2.72E-02	7.24E-06	1.35E+00	4.50E-04	25	667.95	936	14370	0.0E+00	1.1E-01	S		X
132649	Dibenzofuran	5.15E+03	2.38E-02	6.00E-06	3.10E+00	5.15E-04	25	560	824	66400	0.0E+00	1.4E-02	S		X
135988	sec-Butylbenzene	9.66E+02	5.70E-02	8.12E-06	3.94E+00	5.68E-01	25	446.5	679	88730	0.0E+00	1.4E-01	L		X
141786	Ethylacetate	6.44E+00	7.32E-02	9.70E-06	8.03E+04	5.64E-03	25	350.26	523.3	7633.66	0.0E+00	3.2E+00	L		X
156592	cis-1,2-Dichloroethylene	3.55E+01	7.36E-02	1.13E-05	3.50E+03	1.67E-01	25	333.65	544	7192	0.0E+00	3.5E-02	L		X
156605	trans-1,2-Dichloroethylene	5.25E+01	7.07E-02	1.19E-05	6.30E+03	3.84E-01	25	320.85	516.5	6717	0.0E+00	7.0E-02	L		X
205992	Benzo(b)fluoranthene	1.23E+06	2.26E-02	5.56E-06	1.50E-03	4.54E-03	25	715.9	969.27	17000	2.1E-04	0.0E+00	S	X	
218019	Chrysene	3.98E+05	2.48E-02	6.21E-06	6.30E-03	3.87E-03	25	714.15	979	16455	2.1E-06	0.0E+00	S	X	
309002	Aldrin	2.45E+06	1.32E-02	4.86E-06	1.70E-02	6.95E-03	25	603.01	839.37	15000	4.9E-03	1.1E-04	S		X
319846	alpha-HCH (alpha-BHC)	1.23E+03	1.42E-02	7.34E-06	2.00E+00	4.34E-04	25	596.55	839.36	15000	1.8E-03	0.0E+00	S		
541731	1,3-Dichlorobenzene	1.98E+03	6.92E-02	7.86E-06	1.34E+02	1.27E-01	25	446	684	9230.18	0.0E+00	1.1E-01	L		X
542756	1,3-Dichloropropene	4.57E+01	6.26E-02	1.00E-05	2.80E+03	7.24E-01	25	381.15	587.38	7900	4.0E-06	2.0E-02	L		
630206	1,1,1,2-Tetrachloroethane	1.16E+02	7.10E-02	7.90E-06	1.10E+03	9.90E-02	25	403.5	624	9768.282525	7.4E-06	1.1E-01	L		X
1634044	MTBE	7.26E+00	1.02E-01	1.05E-05	5.10E+04	2.56E-02	25	328.3	497.1	6677.66	0.0E+00	3.0E+00	L		
7439976	Mercury (elemental)	5.20E+01	3.07E-02	6.30E-06	2.00E+01	4.40E-01	25	629.88	1750	14127	0.0E+00	3.0E-04	L		

VLOOKUP TABLES



APPENDIX D

SAMPLE DATA ENTRY SHEETS FOR EACH MODEL

DATA ENTRY SHEET

SL-SCREEN
Version 3.1; 02/04

Reset to
Defaults

CALCULATE RISK-BASED SOIL CONCENTRATION (enter "X" in "YES" box)

YES X

OR

CALCULATE INCREMENTAL RISKS FROM ACTUAL SOIL CONCENTRATION (enter "X" in "YES" box and initial soil conc. below)

YES

ENTER Chemical CAS No. (numbers only, no dashes)	ENTER Initial soil conc., C_R ($\mu\text{g}/\text{kg}$)	Chemical
71432		Benzene

MORE
↓

ENTER Depth below grade to bottom of enclosed space floor, L_F (15 or 200 cm)	ENTER Depth below grade to top of contamination, L_t (cm)	ENTER Average soil temperature, T_s ($^{\circ}\text{C}$)	ENTER Vadose zone SCS soil type (used to estimate soil vapor permeability)	OR	ENTER User-defined vadose zone soil vapor permeability, k_v (cm^2)
200	400	10	SCL		

MORE
↓

ENTER Vadose zone SCS soil type Lookup Soil Parameters	ENTER Vadose zone soil dry bulk density, ρ_b^A (g/cm^3)	ENTER Vadose zone soil total porosity, n^V (unitless)	ENTER Vadose zone soil water-filled porosity, θ_w^V (cm^3/cm^3)	ENTER Vadose zone soil organic carbon fraction, f_{oc}^V (unitless)	ENTER Average vapor flow rate into bldg. (Leave blank to calculate) Q_{soil} (L/m)
SCL	1.63	0.384	0.146	0.002	5

MORE
↓

ENTER Averaging time for carcinogens, AT_C (yrs)	ENTER Averaging time for noncarcinogens, AT_{NC} (yrs)	ENTER Exposure duration, ED (yrs)	ENTER Exposure frequency, EF (days/yr)	ENTER Target risk for carcinogens, TR (unitless)	ENTER Target hazard quotient for noncarcinogens, THQ (unitless)
70	30	30	350	1.0E-06	1

END

Used to calculate risk-based
soil concentration.

DATA ENTRY SHEET

SL-ADV
Version 3.1; 02/04

CALCULATE RISK-BASED SOIL CONCENTRATION (enter "X" in "YES" box)

YES

OR

CALCULATE INCREMENTAL RISKS FROM ACTUAL SOIL CONCENTRATION (enter "X" in "YES" box and initial soil conc. below)

YES

Reset to Defaults

ENTER Chemical CAS No. (numbers only, no dashes)	ENTER Initial soil conc., C_R ($\mu\text{g}/\text{kg}$)	Chemical
71432		Benzene

MORE
↓

ENTER Average soil temperature, T_S ($^{\circ}\text{C}$)	ENTER Depth below grade to bottom of enclosed space floor, L_F (cm)	ENTER Depth below grade to top of contamination, L_t (cm)	ENTER Depth below grade to bottom of contamination, (enter value of 0 if value is unknown) L_b (cm)	ENTER Totals must add up to value of L_t (cell G28)			ENTER Soil stratum A SCS soil type (used to estimate soil vapor permeability)	ENTER User-defined stratum A soil vapor permeability, k_v (cm^2)
h_A (cm)	h_B (cm)	h_C (cm)		Thickness of soil stratum A, h_A (cm)	Thickness of soil stratum B, (Enter value or 0) h_B (cm)	Thickness of soil stratum C, (Enter value or 0) h_C (cm)	OR	
10	200	400	600	200	100	100	L	

MORE
↓

ENTER Stratum A SCS soil type Lookup Soil Parameters	ENTER Stratum A soil dry bulk density, ρ_b^A (g/cm^3)	ENTER Stratum A soil total porosity, n^A (unitless)	ENTER Stratum A soil water-filled porosity, θ_w^A (cm^3/cm^3)	ENTER Stratum A soil organic carbon fraction, f_{oc}^A (unitless)	ENTER Stratum B SCS soil type Lookup Soil Parameters	ENTER Stratum B soil dry bulk density, ρ_b^B (g/cm^3)	ENTER Stratum B soil total porosity, n^B (unitless)	ENTER Stratum B soil water-filled porosity, θ_w^B (cm^3/cm^3)	ENTER Stratum B soil organic carbon fraction, f_{oc}^B (unitless)	ENTER Stratum C SCS soil type Lookup Soil Parameters	ENTER Stratum C soil dry bulk density, ρ_b^C (g/cm^3)	ENTER Stratum C soil total porosity, n^C (unitless)	ENTER Stratum C soil water-filled porosity, θ_w^C (cm^3/cm^3)	ENTER Stratum C soil organic carbon fraction, f_{oc}^C (unitless)
L	1.59	0.399	0.148	0.002	L	1.59	0.399	0.148	0.002	S	1.66	0.375	0.054	0.002

MORE
↓

ENTER Enclosed space floor thickness, L_{crack} (cm)	ENTER Soil-bldg. pressure differential, ΔP ($\text{g}/\text{cm}\cdot\text{s}^2$)	ENTER Enclosed space floor length, L_B (cm)	ENTER Enclosed space floor width, W_B (cm)	ENTER Enclosed space height, H_B (cm)	ENTER Floor-wall seam crack width, w (cm)	ENTER Indoor air exchange rate, ER (1/h)	ENTER Average vapor flow rate into bldg. OR Leave blank to calculate Q_{soil} (L/m)
10	40	1000	1000	366	0.1	0.25	5

ENTER Averaging time for carcinogens, AT_C (yrs)	ENTER Averaging time for noncarcinogens, AT_{NC} (yrs)	ENTER Exposure duration, ED (yrs)	ENTER Exposure frequency, EF (days/yr)	ENTER Target risk for carcinogens, TR (unitless)	ENTER Target hazard quotient for noncarcinogens, THQ (unitless)
70	30	30	350	1.0E-06	1

END

Used to calculate risk-based soil concentration.

DATA ENTRY SHEET

SG-SCREEN
Version 3.1; 02/04

Reset to Defaults

Soil Gas Concentration Data

ENTER Chemical CAS No. (numbers only, no dashes)	ENTER Soil gas conc., C_g ($\mu\text{g}/\text{m}^3$)	OR	ENTER Soil gas conc., C_g (ppmv)	Chemical
71432			2.00E+01	Benzene

MORE
↓

ENTER Depth below grade to bottom of enclosed space floor, L_f (15 or 200 cm)	ENTER Soil gas sampling depth below grade, L_s (cm)	ENTER Average soil temperature, T_s ($^{\circ}\text{C}$)	ENTER Vadose zone SCS soil type (used to estimate soil vapor permeability)	OR	ENTER User-defined vadose zone soil vapor permeability, k_v (cm^2)
200	400	10	L		

MORE
↓

ENTER Vadose zone SCS soil type Lookup Soil Parameters	ENTER Vadose zone soil dry bulk density, ρ_b^A (g/cm^3)	ENTER Vadose zone soil total porosity, n^V (unitless)	ENTER Vadose zone soil water-filled porosity, θ_w^V (cm^3/cm^3)	ENTER Average vapor flow rate into bldg. (Leave blank to calculate) Q_{soil} (L/m)
L	1.59	0.399	0.148	5

MORE
↓

ENTER Averaging time for carcinogens, AT_C (yrs)	ENTER Averaging time for noncarcinogens, AT_{NC} (yrs)	ENTER Exposure duration, ED (yrs)	ENTER Exposure frequency, EF (days/yr)
70	30	30	350

END

DATA ENTRY SHEET

SG-ADV
Version 3.1; 02/04

Reset to
Defaults

Soil Gas Concentration Data

ENTER Chemical CAS No. (numbers only, no dashes)	ENTER Soil gas conc., C _g (µg/m ³)	OR	ENTER Soil gas conc., C _g (ppmv)	Chemical
71432				Benzene

Enter soil gas concentration above.

MORE
↓

ENTER Depth below grade to bottom of enclosed space floor, L _F (cm)	ENTER Soil gas sampling depth below grade, L _S (cm)	ENTER Average soil temperature, T _S (°C)	ENTER ENTER ENTER Totals must add up to value of Ls (cell F24)			ENTER Soil stratum A SCS soil type (used to estimate soil vapor permeability)	OR	ENTER User-defined stratum A soil vapor permeability, k _v (cm ²)
200	400	10	200	100	100	L		

MORE
↓

ENTER Stratum A SCS soil type Lookup Soil Parameters	ENTER Stratum A soil dry bulk density, ρ _b ^A (g/cm ³)	ENTER Stratum A soil total porosity, n ^A (unitless)	ENTER Stratum A soil water-filled porosity, θ _w ^A (cm ³ /cm ³)	ENTER Stratum B SCS soil type Lookup Soil Parameters	ENTER Stratum B soil dry bulk density, ρ _b ^B (g/cm ³)	ENTER Stratum B soil total porosity, n ^B (unitless)	ENTER Stratum B soil water-filled porosity, θ _w ^B (cm ³ /cm ³)	ENTER Stratum C SCS soil type Lookup Soil Parameters	ENTER Stratum C soil dry bulk density, ρ _b ^C (g/cm ³)	ENTER Stratum C soil total porosity, n ^C (unitless)	ENTER Stratum C soil water-filled porosity, θ _w ^C (cm ³ /cm ³)
L	1.59	0.399	0.148	L	1.59	0.399	0.148	S	1.66	0.375	0.054

MORE
↓

ENTER Enclosed space floor thickness, L _{crack} (cm)	ENTER Soil-bldg. pressure differential, ΔP (g/cm-s ²)	ENTER Enclosed space floor length, L _B (cm)	ENTER Enclosed space floor width, W _B (cm)	ENTER Enclosed space height, H _B (cm)	ENTER Floor-wall seam crack width, w (cm)	ENTER Indoor air exchange rate, ER (1/h)	ENTER Average vapor flow rate into bldg. OR Leave blank to calculate Q _{soil} (L/m)
10	40	1000	1000	366	0.1	0.25	5

ENTER Averaging time for carcinogens, AT _C (yrs)	ENTER Averaging time for noncarcinogens, AT _{NC} (yrs)	ENTER Exposure duration, ED (yrs)	ENTER Exposure frequency, EF (days/yr)
70	30	30	350

END

DATA ENTRY SHEET

GW-SCREEN
Version 3.1; 02/04

CALCULATE RISK-BASED GROUNDWATER CONCENTRATION (enter "X" in "YES" box)

YES

OR

CALCULATE INCREMENTAL RISKS FROM ACTUAL GROUNDWATER CONCENTRATION
(enter "X" in "YES" box and initial groundwater conc. below)

YES

Reset to
Defaults

ENTER Chemical CAS No. (numbers only, no dashes)	ENTER Initial groundwater conc., C_w ($\mu\text{g/L}$)	Chemical
71432		Benzene

MORE
↓

ENTER Depth below grade to bottom of enclosed space floor, L_F (cm)	ENTER Depth below grade to water table, L_{WT} (cm)	ENTER SCS soil type directly above water table	ENTER Average soil/ groundwater temperature, T_s ($^{\circ}\text{C}$)	ENTER Average vapor flow rate into bldg. (Leave blank to calculate) Q_{soil} (L/m)
200	400	SC	10	5

MORE
↓

ENTER Vadose zone SCS soil type (used to estimate soil vapor permeability)	OR	ENTER User-defined vadose zone soil vapor permeability, k_v (cm^2)	ENTER Vadose zone SCS soil type Lookup Soil Parameters	ENTER Vadose zone soil dry bulk density, ρ_b^v (g/cm^3)	ENTER Vadose zone soil total porosity, n^v (unitless)	ENTER Vadose zone soil water-filled porosity, θ_w^v (cm^3/cm^3)
SCL			SCL	1.63	0.384	0.146

MORE
↓

ENTER Target risk for carcinogens, TR (unitless)	ENTER Target hazard quotient for noncarcinogens, THQ (unitless)	ENTER Averaging time for carcinogens, AT_C (yrs)	ENTER Averaging time for noncarcinogens, AT_{NC} (yrs)	ENTER Exposure duration, ED (yrs)	ENTER Exposure frequency, EF (days/yr)
1.0E-06	1	70	30	30	350

Used to calculate risk-based groundwater concentration.

DATA ENTRY SHEET

GW-ADV
Version 3.1; 02/04

CALCULATE RISK-BASED GROUNDWATER CONCENTRATION (enter "X" in "YES" box)

YES

Reset to Defaults

CALCULATE INCREMENTAL RISKS FROM ACTUAL GROUNDWATER CONCENTRATION (enter "X" in "YES" box and initial groundwater conc. below)

YES

ENTER
Chemical CAS No. (numbers only, no dashes)

ENTER
Initial groundwater conc., C_w ($\mu\text{g/L}$)

71432

Chemical

Benzene

MORE
↓

ENTER
Average soil/groundwater temperature, T_s ($^{\circ}\text{C}$)

ENTER
Depth below grade to bottom of enclosed space floor, L_f (cm)

ENTER
Depth below grade to water table, L_{WT} (cm)

ENTER
Thickness of soil stratum A, h_A (cm)

ENTER
Thickness of soil stratum B, h_B (cm)

ENTER
Thickness of soil stratum C, h_C (cm)

Totals must add up to value of L_{WT} (cell G28)

ENTER
Soil stratum directly above water table, (Enter A, B, or C)

ENTER
SCS soil type directly above water table

ENTER
Soil stratum A SCS soil type (used to estimate soil vapor permeability)

OR

ENTER
User-defined stratum A soil vapor permeability, k_v (cm^2)

10

200

400

300

50

50

C

SC

L

MORE
↓

ENTER
Stratum A SCS soil type
Lookup Soil Parameters

ENTER
Stratum A soil dry bulk density, ρ_b^A (g/cm^3)

ENTER
Stratum A soil total porosity, n^A (unitless)

ENTER
Stratum A soil water-filled porosity, θ_w^A (cm^3/cm^3)

ENTER
Stratum B SCS soil type
Lookup Soil Parameters

ENTER
Stratum B soil dry bulk density, ρ_b^B (g/cm^3)

ENTER
Stratum B soil total porosity, n^B (unitless)

ENTER
Stratum B soil water-filled porosity, θ_w^B (cm^3/cm^3)

ENTER
Stratum C SCS soil type
Lookup Soil Parameters

ENTER
Stratum C soil dry bulk density, ρ_b^C (g/cm^3)

ENTER
Stratum C soil total porosity, n^C (unitless)

ENTER
Stratum C soil water-filled porosity, θ_w^C (cm^3/cm^3)

L

1.59

0.399

0.148

L

1.59

0.399

0.148

SC

1.63

0.385

0.197

MORE
↓

ENTER
Enclosed space floor thickness, L_{crack} (cm)

ENTER
Soil-bldg. pressure differential, ΔP (g/cm-s^2)

ENTER
Enclosed space floor length, L_B (cm)

ENTER
Enclosed space floor width, W_B (cm)

ENTER
Enclosed space height, H_B (cm)

ENTER
Floor-wall seam crack width, w (cm)

ENTER
Indoor air exchange rate, ER (1/h)

ENTER
Average vapor flow rate into bldg. OR Leave blank to calculate Q_{soil} (L/m)

10

40

1000

1000

366

0.1

0.25

5

MORE
↓

ENTER
Averaging time for carcinogens, AT_C (yrs)

ENTER
Averaging time for noncarcinogens, AT_{NC} (yrs)

ENTER
Exposure duration, ED (yrs)

ENTER
Exposure frequency, EF (days/yr)

ENTER
Target risk for carcinogens, TR (unitless)

ENTER
Target hazard quotient for noncarcinogens, THQ (unitless)

70

30

30

350

1.0E-06

1

END

Used to calculate risk-based groundwater concentration.

APPENDIX E
BIBLIOGRAPHY AND REFERENCE LIST

- American Petroleum Institute (API). 1998. Assessing the Significance of Subsurface Contaminant Vapor Migration to Enclosed Spaces, Site-Specific Alternatives to Generic Estimates. API Publication No. 4674. Washington, D.C.
- American Petroleum Institute. 2002. Practical Guidance for Assessing the "Groundwater to Indoor Air" Vapor Migration Pathway at Petroleum Hydrocarbon Sites..
- Bonazountas, M., and J. M. Wagner. 1984. "SESOIL,". A Seasonal Soil Compartment Model. Prepared by Arthur D. Little for U.S. EPA, Office of Toxic Substances.
- Brooks, R. H., and A. T. Corey. 1966. Properties of porous media affecting fluid flow. J. Irrig. Drainage Div., ASCE Proc. 72 (IR2), 61-88.
- Burkhard, L. P., D. E. Armstrong, and A. W. Andren. 1985. Henry's law constants for the polychlorinated biphenyls. Environ. Sci. Technology, 19:590-596.
- Carsel, R. F., and R. S. Parrish. 1988. Developing joint probability distributions of soil water retention characteristics. Water Resources Research, 24(5):755-769.
- Clapp, P. B. and G. Homberger. 1978. Empirical Equations for Some Soil Hydraulic Properties. Water Resources Research, Vol. 14 (4) 601-604.
- Cody, R. J. 2002. Groundwater to Indoor Air: Introductory Comments. Technical Support Project, General Meeting. Denver, Colorado.
- Dawson, H. 2002. Groundwater to Indoor Air Vapor Intrusion Issues. TSP General Meeting. Denver, CO.
- Dawson, H. E. 2002. Reliability of screening level approaches for evaluating the vapor intrusion to indoor air pathway. Presented at the 2002 RCRA National Meeting Washington, D.C.
- DiPersio, T., and J. Fitzgerald. 1995. Guidelines for the Design, Installation, and Operation of Sub-Slab Depressurization Systems. Prepared for Massachusetts Department of Environmental Protection, Northeast Regional Office.
- Dunn, I. S., L. R. Anderson, and F. W. Keifer. 1980. Fundamentals of Geotechnical Analysis. John Wiley & Sons, New York, New York.
- Eagleson, P. S. 1978. Climate, Soil, and Vegetation 3. A Simplified Model of Soil Moisture Movement in the Liquid Phase. Water Resources Research, Vol. 14(5):722-730.
- Eaton, R. S., and A. G. Scott. 1984. Understanding radon transport into houses. Radiation Protection Dosimetry, 7:251-253.

Environmental Quality Management, Inc. 2000. User's Guide for the NAPL-SCREEN and NAPL-ADV Models for Subsurface Vapor Intrusion into Building. Prepared for U.S. EPA.

Environmental Quality Management, Inc., User's Guide for the Johnson and Ettinger (1991) Model for Subsurface Vapor Intrusion into Buildings. Prepared for U.S. EPA Office of Emergency and Remedial Response. Washington, DC. U.S. EPA, 2000,

Environmental Quality Management, Inc., Supplemental Guidance for Evaluating the Vapor Intrusion to Indoor Air Pathways. Prepared for the USEPA Superfund Program Office of Emergency Response and Remediation. Washington, DC. December 2001

Ettinger, R. 2002. Vapor Intrusion Modeling: Theory and Implications. Indoor Air Session, Technical Support Project Meeting. Denver, CO.

Fetter, C. W. 1994. Applied Hydrogeology, 3rd Ed., Prentice-Hall, Inc. Englewood Cliffs, New Jersey.

Fitzpatrick, N. A., and J. J. Fitzgerald. 1996. An evaluation of vapor intrusion into buildings through a study of field data. Presented at the 11th Annual Conference on Contaminated Soils. University of Massachusetts, Amherst.

Fitzpatrick, N. A., and J. J. Fitzgerald. 1997. An evaluation of vapor intrusion into buildings through a study of field data. In: Soil Vapor Transport to Indoor Air Workshop, February 6-7, 1997, Brea, California.

Fischer, M. L., A. J. Bentley, K. A. Dunkin, A. T. Hodgson, W. W. Nazaroff, R. G. Sexto, and J. M. Daisey. 1996. Factors affecting indoor air concentrations of volatile organic compounds at a site of subsurface gasoline contamination. Environ. Sci. Technol., 30(10):2948-2957.

Freeze, R. A., and J. A. Cherry. 1979. Groundwater. Prentice-Hall Inc. : Englewood Cliffs, New Jersey.

Freijer, J. I. 1994. Calibration of jointed tube model for the gas diffusion coefficient in soils. Soil Sci. Soc. Am. J., 58:1067-1076.

Gillham, R. W. 1984. The capillary fringe and its effect on water table response. Journal of Hydrology, 67:307-324.

Grimsrud, D. T., M. H. Sherman, and R. C. Sonderegger. 1983. Calculating infiltration: implications for a construction quality standard. In: Proceedings of the American Society of Heating, Refrigerating and Air-conditioning Engineers Conference, Thermal Performance of Exterior Envelopes of Buildings II., ASHRAE. SP38, pp. 422-452, Atlanta, Georgia.

Hartman, B. 2002. Reevaluating the Upward Vapor Migration Risk Pathway. LUSTLine Bulletin 41.

Hartman, B. 2002. The Upward Migration of Vapors. LUSTLine Bulletin 27.

Hasset, J. J., W. L. Banwart, and R. A. Griffin. 1983. Correlation of Compound Properties with Sorption Characteristics of Non-polar Compounds in Soils and Sediments: Concepts and Limitations in Environment and Solid Wastes: Characterization, Treatment, and Disposal. Butterworth Publishers: London. pp 161-178.

Hawker, D. W., and D. W. Connell. 1988. Octanol-water partition coefficients of polychlorinated biphenyl congeners. Environ. Sci. Technology, 22:382-387.

Hers, I. 2002. Subsurface Vapor Intrusion to Indoor Air Pathway: Model Predictions and Comparisons to Field Data. U.S. EPA RCRA National Meeting.

Hers, I. June 3, 2002 Technical Memorandum to Debbie Newberry, USEPA OSW. Input Parameters for OSWER Wide Guidance for Vapor Intrusion Pathway.

Hofelt, C. Addressing the Vapor Intrusion Pathway in Texas. Texas Natural Resource Conservation Commission, Toxicology and Risk Assessment Section.

Howard, P. H., R. S. Boethling, W. F. Jarvis, W. M. Meylan, and E. M. Michalenko. 1991. Handbook of Environmental Degradation Rates. Lewis Publishers, Chelsea, Michigan. 725 pp.

Hubbard, J. 1999. Region III Soil-to-Groundwater SSLs. Letter to RBC Table Users.

Johnson, P. C. May 2002. Identification of Critical Parameters for the Johnson and Ettinger (1991) Vapor Intrusion Model. American Petroleum Institute Bulletin No. 17, Washington, DC.

Johnson, P. C., R. A. Ettinger, J. Kurtz, R. Bryan, and J. E. Kester. 2002. Migration of Soil Gas Vapors to Indoor Air: Determining Vapor Attenuation Factors Using a Screening-Level Model and Field Data from the CDOT-MTL Denver, Colorado. Technical Task Force Bulletin No. 16, American Petroleum Institute. April.

Johnson, P. C., and R. A. Ettinger. 1991. Heuristic model for predicting the intrusion rate of contaminant vapors in buildings. Environ. Sci. Technol. 25: 1445-1452.

Johnson, P. C., M. B. Hertz, and D. L. Beyers. 1990. Estimates for hydrocarbon vapor emissions resulting from service station remediations and buried gasoline-contaminated soils. In: Petroleum Contaminated Soils, Vol. 3., Lewis Publishers, Chelsea, Michigan

- Jury, W. A. undated. A Users Manual for the Environmental Fate Screening Model Programs. Submitted to California Department of Health Services.
- Jury, W. A., R. Grover, W. F. Spencer, and W. J. Farmer. 1980. Modeling Vapor Losses of Soil Incorporated Triallate. *Soil Sci. Soc. Am. J.*,44:445-450.
- Jury, W. A., W. F. Spencer, and W. J. Farmer. 1983. Behavior Assessment Model for Trace Organics in Soil: I. Model Description. *J. Environ. Qual.*, 12(4):558-564.
- Jury, W. A., W. J. Farmer, and W. F. Spencer. 1984. Behavior Assessment Model for Trace Organics in Soil: II. Chemical Classification and Parameter Sensitivity. *J. Environ. Qual.*,(13):567-572.
- Jury, W. A., W. F. Spencer, and W. J. Farmer. 1984. Behavior Assessment Model for Trace Organics in Soil: III. Application of Screening Model. *J. Environ. Qual.*,13(4):573-579.
- Jury, W. A., W. F. Spencer, and W. J. Farmer. 1984. Behavior Assessment Model for Trace Organics in Soil: IV. Review of Experimental Evidence. *J. Environ. Qual.*, 13(4):580-586.
- Jury, W. A., D. Russo, G. Streile, and H. El Abd. 1990. Evaluation of Volatilization by Organic Chemicals Residing Below the Soil Surface. *Water Resources Res.* 26(1):13-20.
- Kemblowski, M. and P. C. Johnson. 2000. Environmental Monitoring, Modeling, and Management and Bayesian Belief Networks. Envirosoft 2000. Bilbao, Spain.
- Koontz, M. D., and H. E. Rector. 1995. Estimation of Distributions for Residential Air Exchange Rates. EPA Contract 68-D9-0166, Work Assignment 3-19. U.S. EPA, Office of Pollution Prevention and Toxics. Washington, DC.
- Kremesec, V. 2002. API Case Examples of the Evaluation of the EI Vapor Pathway Guidance. American Petroleum Institute.
- Kurz, D. W. 2000. Estimating residential indoor air impacts due to groundwater contamination. Proceedings of the 2000 Conference on Hazardous Waste Research.
- Larsen, K. 2002. Applying the Hazard Ranking System (HRS) to Vapor Intrusion Sites. 2002 National Site Assessment Conference. Austin, Texas.
- Last, G., and M. Fayer. 1999. Vandose Zone Conceptual Model Technical Approach for SAC Rev. 0. System Assessment Capability Workshop. Richland, Washington.
- Ley, T.W., Stevens, R. G., Topielec, R and Neibling, W. H. Soil Water Monitoring and Measurement. Pacific Northwest Extension Publication 0475, 1994.

Little, J. C., J. M. Daisy, and W. W. Nazaroff. 1992. Transport of subsurface contaminants into buildings: an exposure pathway for volatile organics. *Environ. Sci. Technol.* 26: 2058-2066.

Lohman, S. W. 1972. *Ground-Water Hydraulics*. Geological Survey Professional Paper 708, U.S. Department of the Interior, Washington, DC.

Loureiro, C. O., L. M. Abriola, J. E. Martin, and R. G. Sextro. 1990. Three-dimensional simulation of radon transport into houses with basements under constant negative pressure. *Environ. Sci. Technology*, 24:1338-1348.

Lyman, W. J., W. F. Reehl, and D. H. Rosenblatt. 1990. *Handbook of Chemical Property Estimation Methods*. McGraw Hill: New York, New York.

Ma, Y., M. Kemblowski, and G. E. Urroz. Kinematic Mixing and Chemical Reactions in Heterogeneous Aquifers. Department of Civil and Environmental Engineering, Utah Water Research Laboratory, Utah State University.

Mayer, R., J. Letey, and W. J. Farmer. 1974. Models for Predicting Volatilization of Soil Incorporated Pesticides. *Soil Sci. Soc. America Proc.* (38):563-568.

McCarthy, K. A., and R. L. Johnson. 1993. Transport of volatile organic compounds across the capillary fringe. *Water Resources Research*, 29(6):1675-1683.

McHugh, T. E. 2002. Evaluation of the Groundwater-to-Indoor Air Exposure Pathway. Presentation Materials

Michigan Environmental Science Board. 2001. Evaluation of the Michigan Department of Environmental Quality's Generic Groundwater and Soil Volatilization to Indoor Air Inhalation Criteria.

Millington, R. J., and J. M. Quirk. 1961. Permeability of porous solids. *Trans. Faraday Soc.*, 57:1200-1207.

Nazaroff, W. W. 1988. Predicting the rate of ²²²Rn entry from soil into the basement of a dwelling due to pressure-driven air flow. *Radiation Protection Dosimetry*, 24:199-202.

Nazaroff, W. W., H. Feustel, A. V. Nero, K. L. Revan, D. T. Grimsrud, M. A. Essling, and R. E. Toohey. 1985. Radon transport into a detached one-story house with a basement. *Atmospheric Environment*, 19(1):31-46.

Nazaroff, W. W., S. R. Lewis, S. M. Doyle, B. A. Moed, and A. V. Nero. 1987. Experiments on pollutant transport from soil into residential basements by pressure-driven airflow. *Environ. Sci. Technology*, 21(5):459-466.

Nelson, D. W., and L. E. Sommers. 1982. Total carbon, organic carbon, and organic matter. In: A. L. Page (ed), *Methods of Soil Analysis. Part 2. Chemical and Microbiological Properties*. 2nd Ed., 9(2):539-579, American Society of Agronomy, Madison, Wisconsin.

New Jersey Department of Environmental Protection. 1999. *Indoor Air Sampling Guide for Volatile Organic Contaminants*.

Nielson, K. K., and V. C. Rogers. 1990. Radon transport properties of soil classes for estimating indoor radon entry. In: F. T. Cross (ed), *Proceedings of the 29th Hanford Symposium of Health and the Environment. Indoor Radon and Lung Cancer: Reality or Myth? Part 1*. Battelle Press, Richland, Washington.

Nudelman, N. S., S. M. Rios, and O. Katusich. 2002. Fate of the Oil Residuals in Patagonian Soils Effects of the Environmental Exposure Time. *Contaminated Soil Sediment & Water Magazine* <http://www.aehsmag.com/issues/2002/april_may/patagonian.htm>.

O'Grady, M. 2002. Indoor Air Pathway-Implications for Site Assessments. EPA 2000 National Site Assessment Conference Homepage. <http://www.epa.gov/superfund/programs/siteasmt/sa_conf/ogrady/ogrady.htm>.

Park, H. S. 1999. A Method for Assessing Soil Vapor Intrusion from Petroleum Release Sites: Multi-phase/Multi-fraction Partitioning.

Parker, J. C., R. J. Lenhard, and T. Kuppusamy. 1987. A parametric model for constitutive properties governing multiphase flow in porous media. *Water Resources Research*, 23(4):618-624.

Parker, G. B., M. McSorley, and J. Harris. 1990. The northwest residential infiltration survey: A field study of ventilation in new houses in the Pacific northwest. In: *Air Change Rate and Air Tightness in Buildings*, ASTM STP 1067, pp:93-103. American Society for Testing and Materials, Philadelphia, Pennsylvania.

Parsons Engineering Science, Inc. 2000. Methyl Tertiary-Butyl Ether (MTBE) Its Movement and Fate in the Environment and Potential for Natural Attenuation. Presented to The Air Force Center for Environmental Excellence.

Pennsylvania Department of Environmental Protection. March 2002. Science Advisory Board Meeting Minutes. <<http://www.dep.state.pa.us/dep/subject/advcoun/cleanup/mar2min.htm>>.

Perry's Chemical Engineers' Handbook, 7th Ed. 1977. McGraw-Hill, New York, New York.

Radian Corporation. 1989. Short-Term Fate and Persistence of Motor Fuels in Soils. American Petroleum Institute Report DCN 89-204-145-04.

Radian International. 2000. Guide to Optimal Groundwater Monitoring: Interim Final prepared for Naval Facilities Engineering Service Center, Port Hueneme, California.

Roggemans, S., C. L. Bruce, P. C. Johnson, and R. L. Johnson. 2001. Vadose Zone Natural Attenuation of Hydrocarbon Vapors: An Empirical Assessment of Soil Gas Vertical Profile Data. API Soil and Groundwater Technical Task Force Bulletin Number 15. Washington, DC.

Rong, Y. 2002. Laboratory Detection Limits. Contaminated Soil Sediment & Water Magazine April-May <http://www.aehsmag.com/issues/2002/april_may/laboratory_detection.htm>.

Sager, S. L., L. D. Braddy, and C. H. Day. 2002. The Crack Factor in Vapor Intrusion Calculations. Society for Risk Analysis 1997 Annual Meeting Homepage. <<http://www.riskworld.com/Abstract?1997/SRAam97/ab7ab357.htm>>.

San Diego County Department of Environmental Health, Land and Water Quality Division. 1999. User's Guide to the Vapor Risk 2000.

Sariyev, A., et al. 2002. Mathematical Modeling of Soil Hydraulic Properties and Numerical Analyses of Moisture Dynamic. <http://www.toprak.org.tr/isd/can_53.htm>.

Schaap, M. G., F. J. Leij, and M. Th. van Genuchten. 1997. Neural network analysis for hierarchical prediction of soil water retention and saturated hydraulic conductivity. Submitted to Soil Sci. Soc. Am. J. Personal communication from M. Th. van Genuchten, June 23, 1997.

Schroeder, P. R., R. L. Peyton, B. M. McEnroe, and J. W. Sjostrom. 1989. The Hydrologic Evaluation of Landfill Performance (HELP) Model. Prepared for the U.S. Environmental Protection Agency, Hazardous Waste Engineering Research Laboratory, Cincinnati, Ohio.

Shan, C., and D. B. Stephens. 1995. An Analytical Solution for Vertical Transport of Volatile Chemicals in the Vadose Zone. J. of Contaminant Hydrology, Vol. 18, pp. 259-277.

Sorini, S. S., J. F. Schabron, and J. F. Rovani, Jr. 2002. Evaluation of VOC Loss from Soil Samples: Extrusion into Empty VOA Vials, Refrigerated Storage, and Methanol Injection in Preparation for Volatile Organic Analysis. Contaminated Soil Sediment & Water Magazine April-May <http://www.aehsmag.com/issues/2002/april_may/vocloss.htm>.

Spencer, W. F., M. M. Cliath, W. A. Jury, and L. Z. Zhang. 1988. Volatilization of Organic Chemicals from Soil as Related to Their Henry's Law Constants. J. Environ. Qual., 17(3):504-509.

Thibodeaux, L. J. 1981. Estimating the Air Emissions of Chemicals from Hazardous Waste Landfills. J. of Haz. Mat. 4:235-244.

- Toy, T. J., A. J. Kuhaida, Jr., and B. E. Munson. 1978. The predictions of mean monthly soil temperature from mean monthly air temperature, *Soil Science*, 126:181-189.
- Truesdale, R. S., M. L. Lowry, and S. N. Wolf. 2002. Draft Procedure and Issues Report: Vapor Intrusion Pathway. Prepared for the Indiana Department of Environmental Management.
- U.S. Department of Energy. 1995 Housing Characteristics, Report No. DOE/EIA-0314(93). Energy Information Administration, Washington, DC.
- U.S. Department of the Navy. Regulatory Basis for Conducting Ecological Risk Assessments. Navy Guidance for Conducting Ecological Risk Assessments.
- U.S. EPA. 2003. Prediction of Chemical Reactivity Parameters and Physical Properties of Organic Compounds from Molecular Substitute Using SPARC.
- U.S. EPA. 2002. EMSOFT Users Guide Office of Research and Development National Center for Environmental Assessment. NCEA –W-0073 R
- U.S. EPA. Office of Solid Waste and Emergency Response (OSWER)
Draft of the Guidance For Evaluating The Vapor Intrusion to Indoor Air Pathway From Groundwater Soils (Subsurface Vapor Intrusion Guidance) November 29, 2002.
- U.S. EPA OAQPS. 2002. Landfill Air Emissions Estimation Model. EPA-OAQPS Landfill Air Emissions Estimation Model Homepage. <<http://www.epa.gov/oar/oaqps/landfill.html>>.
- U.S. EPA. 2002. Region 6. Human Health Medium-Specific Screening Levels. EPA Region 6 - RCRA Human Health Medium Specific Screening Levels.
<http://www.epa.gov/earth1r6/6pd/rcra_c/pd-n/screen.htm>.
- U.S. EPA. 2000. Institutional Controls: A Site Manager's Guide to Identifying, Evaluating and Selecting Institutional Controls at Superfund and RCRA Corrective Action Cleanups. Office of Solid Waste and Emergency Response. EPA 540-F-00-005.
- U.S. EPA. 1998. BIOPLUME III: Natural Attenuation Decision Support System User's Manual Version 1.0. Office of Research and Development. EPA/600/R-98/010.
- U.S. EPA 1996, Soil Screening Guidance: User's Guide. EPA/540/R-96/018. Office of Solid Waste and Emergency Response. Washington, DC.
- U.S. EPA 1996. Soil Screening Guidance: Technical Background Document. EPA/540/R-95/128. Office of Solid Waste and Emergency Response. Washington, DC.
- U.S. EPA 1995, Review of Mathematical Modeling for Evaluating Soil Vapor Extraction Systems. EPA/540/R-95-513. Office of Research and Development, Washington, DC.

U.S. EPA 1992, Assessing Potential Indoor Air Impacts for Superfund Sites. National Technical Guidance Study Series. Office of Air Quality Planning and Standards, Research Triangle Park, North Carolina. EPA-451/R-92-002.

U.S. EPA, 1988. Superfund Exposure Assessment Manual. Office of Solid Waste and Emergency Response, Washington, DC. EPA/540/1-88/001.

Van Genuchten, M. Th. 1980. A closed-form equation for predicting the hydraulic conductivity of unsaturated soils, *Soil Science Society Am. Journal*, 44:892-898.

Vereecken, H., J. Maes, J. Feyen, and P. Darius. 1989. Estimating the soil moisture retention characteristic from texture, bulk density, and carbon content. *Soil Sci.*, 148:389-403.

Vereecken, H., J. Maes, and J. Feyen. 1990. Estimating unsaturated hydraulic conductivity from easily measured soil properties. *Soil Sci.*, 149:1-12.

Vogel, T., K. Huang, R. Zhang, and M. Th. van Genuchten. 1996. The HYDRUS Code for Simulating One-Dimensional Water Flow, Solute Transport, and Heat Movement in Variably - Saturated Media, Version 5.0. U.S. Salinity Laboratory, Agricultural Research Service, U.S. Department of Agriculture, Riverside, California. Research Report No. 140.

Waitz, M. F., J. Freijer, P. Kruele, and F. Swartjes. 1996. The VOLASOIL Risk Assessment Model Based on CSOIL for Soils Contaminated with Volatile Compounds. Report No. 715810014. National Institute for Public Health and the Environment. Bilthoven, The Netherlands.

Wenning, R. J. 2002. Focus on Sediments: USEPA Principles for Managing Contaminated Sediment Risks at Hazardous Waste Sites. *Contaminated Soil Sediment & Water Magazine* <http://www.aehsmag.com/issues/2002/april_may/USEPA.htm>.

Evaluation of the Johnson and Ettinger Model for Prediction of Indoor Air Quality

by Ian Hers, Reidar Zapf-Gilje, Paul C. Johnson, and Loretta Li

Abstract

Screening level models are now commonly used to estimate vapor intrusion for subsurface volatile organic compounds (VOCs). Significant uncertainty is associated with processes and models and, to date, there has been only limited field-based evaluation of models for this pathway. To address these limitations, a comprehensive evaluation of the Johnson and Ettinger (J&E) model is provided through sensitivity analysis, comparisons of model-predicted to measured vapor intrusion for 11 petroleum hydrocarbon and chlorinated solvent sites, and review of radon and flux chamber studies. Significant intrusion was measured at five of 12 sites with measured vapor attenuation ratios (α_m 's) (indoor air/source vapor) ranging from $\sim 1 \times 10^{-6}$ to 1×10^{-4} . Higher attenuation ratios were measured for studies using radon, inert tracers, and flux chambers; however, these ratios are conservative owing to boundary conditions and tracer properties that are different than those at most VOC-contaminated sites. Reasonable predictions were obtained using the J&E model with comparisons indicating that model-predicted vapor attenuation ratios (α_p 's) were on the same order, or less than the α_m 's. For several sites, the α_m were approximately two orders of magnitude less than the α_p 's indicating that the J&E model is conservative in these cases. The model comparisons highlight the importance in using appropriate input parameters for the J&E model. The regulatory implications associated with use of the J&E model to derive screening criteria are also discussed.

Introduction

The use of models to predict indoor air quality associated with volatile organic compound (VOC) contamination in soil and ground water is now commonplace (ASTM 1995; Johnson et al. 1998, Hers et al. 2002). Screening models typically used for this pathway are the Johnson and Ettinger (1991) model (henceforth referred to as the J&E model), or variants thereof. Processes controlling the intrusion of VOC vapors into buildings are not well understood, the accuracy of the J&E model is uncertain, and there have been only limited comparisons of model predictions to field data. There are also substantial differences in the way in which the J&E model is used for regulatory purposes.

To address these limitations, this paper presents a comprehensive evaluation of the J&E model based on theoretical considerations and field data from petroleum hydrocarbon and chlorinated solvent sites, and radon and flux chamber studies. Data sources are published studies, consultant or agency reports, and a field-based research program conducted by the authors. Included in the data sets analyzed are several recent groundbreaking investigations at chlorinated solvent sites.

The paper begins with an analysis of methods for estimating input parameters for the J&E model and their effect on model sensitivity and uncertainty. This analysis provides the needed context for the methods employed to interpret the field data used for this study. It is also important because it is

essential that model attributes and potential limitations be understood before using field data to evaluate the predictive capabilities of a model. Field-based methods for the evaluation of vapor attenuation ratio (α), defined as the indoor air concentration divided by the source vapor concentration, are evaluated next. The primary focus is measured vapor attenuation ratios (α_m) from 11 sites with petroleum hydrocarbon and chlorinated solvent contamination. Information from tracer studies using radon or an injected tracer such as sulphur hexafluoride (SF_6), and flux chamber studies are also reviewed. The measured α_m from field studies are compared to model-predicted vapor attenuation ratios (α_p) using the J&E model. Trends in the data are qualitatively evaluated and possible factors affecting vapor intrusion are considered. The paper also comments on the use of the J&E model to derive regulatory screening criteria.

J&E Model Input Parameters, Sensitivity, and Uncertainty

The basic form of the J&E model couples one-dimensional steady-state diffusion through soil, and diffusion and advection through a building envelope (i.e., foundation). A simple "box" model, which assumes uniform and instantaneous mixing of chemicals within the building enclosure, is used to estimate the indoor air concentration. Model sensitivity and uncertainty analysis and input needed for comparisons of

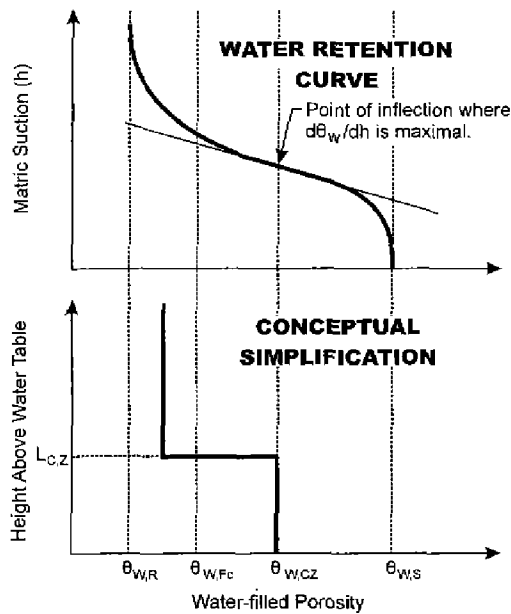

Figure 1. Conceptual simplification of water retention curve for purposes of estimating moisture contents and capillary rise ($\theta_{w,R}$, $\theta_{w,FC}$, $\theta_{w,CZ}$, $\theta_{w,S}$ are the residual, field capacity, capillary zone, and saturated water contents).

model predictions to field data all require estimation of effective diffusion coefficient and soil gas advection rate. Because the available data varied, different methods were used to estimate these input parameters and interpret field data. The estimation methods subsequently used in this paper are discussed in the following sections.

Estimation of Effective Diffusion Coefficient (Air-Filled and Total Porosity)

The J&E model uses the Millington and Quirk (1961) relationship to estimate the effective diffusion coefficient (D_T^{eff}), as follows:

$$D_T^{eff} = (\theta_a^{10/3} / \theta^2) * D_{air} + 1/H' * (\theta_w^{10/3} / \theta^2) * D_{water}$$

where θ_a , θ_w , and θ are the air-filled, water-filled, and total porosity; D_{air} and D_{water} are free-air and free-water diffusion coefficients (L^2T^{-1}); and H' is the dimensionless Henry's law constant.

A common method for estimating air-filled and total porosity directly uses the measured soil moisture content and bulk density. A potential disadvantage is that soil disturbance during sampling can lead to inaccurate moisture, density, and hence, porosity estimates. Samples obtained adjacent to buildings may not be representative of conditions below buildings owing to the drying of soil that can occur.

A second method involves the use of the van Genuchten (VG) model (van Genuchten 1980) to predict the water retention parameters for U.S. Soil Conservation Service (SCS) soil types, based on VG model curve-fit parameters computed by Schaap and Leij (1998) (Simplified VG method). This method, developed by Environmental Quality Management Inc. (EQM 2000), is incorporated in U.S. EPA guidance for this

pathway. The VG model parameters are, in turn, used to develop a simplified step function for water-filled porosity (Figure 1). The capillary zone ($\theta_{w,CZ}$) water-filled porosity is equal to the moisture content at the inflection point in the water retention curve where $d\theta_w/dh$ is maximal, as suggested by Waitz et al. (1996) (where θ_w and h equal the water-filled porosity and matric suction, respectively). Vapor-phase diffusion becomes negligible once the water-filled porosity exceeds the $\theta_{w,CZ}$. The height of the capillary zone is estimated using an equation for capillary rise in a tube (Fetter 1994), and mean particle size for the SCS soil textural classifications (Nielson and Rogers 1990). The water-filled porosity above the capillary zone is user defined; we suggest a practical range below a building is between the residual water content and field capacity.

The simplified VG model likely predicts lower than actual water-filled porosity in soil, for the capillary transition zone (Figure 1). Because diffusion rates are much higher in air than water, this simplification likely results in conservative (high) diffusion estimates through the capillary transition zone. However, this conservatism may be counterbalanced by nonrepresentative assumptions for the ground water contamination source. The common paradigm for prediction of cross-media VOC transport is that dissolved chemicals are present below a static water table, and that transport through the capillary transition zone is limited to vapor- and aqueous-phase diffusion. In reality, there will be some lateral ground water flow and dispersive mixing of chemicals in the tension-saturated zone, and vertical movement of chemicals as a result of water-table fluctuations. There is limited information on VOC migration in the capillary transition zone. One study, involving a large chamber, showed that the pore-water concentrations in the tension-saturated zone were similar to those below the water table, and showed a sharp decline in concentrations near the top of the tension-saturated zone (McCarthy and Johnson 1993). The implication is that a more representative top boundary for dissolved ground water contaminants may be some distance above the water table.

Estimation of Soil Gas Advection Rate (Q_{soil})

The method often used with the J&E model for estimating the soil gas advection rate (Q_{soil}) through the building envelope is an analytical solution for two-dimensional soil gas flow to a small horizontal drain (Nazaroff 1992). This model is used to simulate gas flow to an edge crack located at the perimeter of a building (perimeter crack model). The Q_{soil} (L^3T^{-1}) is estimated as follows:

$$Q_{soil} = \frac{2 \pi k_a \Delta P X_{crack}}{\mu \ln \left(\frac{2 z_{crack}}{r_{crack}} \right)} \quad (2)$$

where k_a is the soil-air permeability (L^2), ΔP is the pressure difference between the building and ambient air, X_{crack} is the perimeter crack length (L), μ is the gas viscosity ($ML^{-1}T^{-1}$), z_{crack} is the depth to edge crack (L), and r_{crack} is the crack radius (L). The ratio of cracks to total subsurface foundation area (i.e., base and walls) (η) can be expressed as

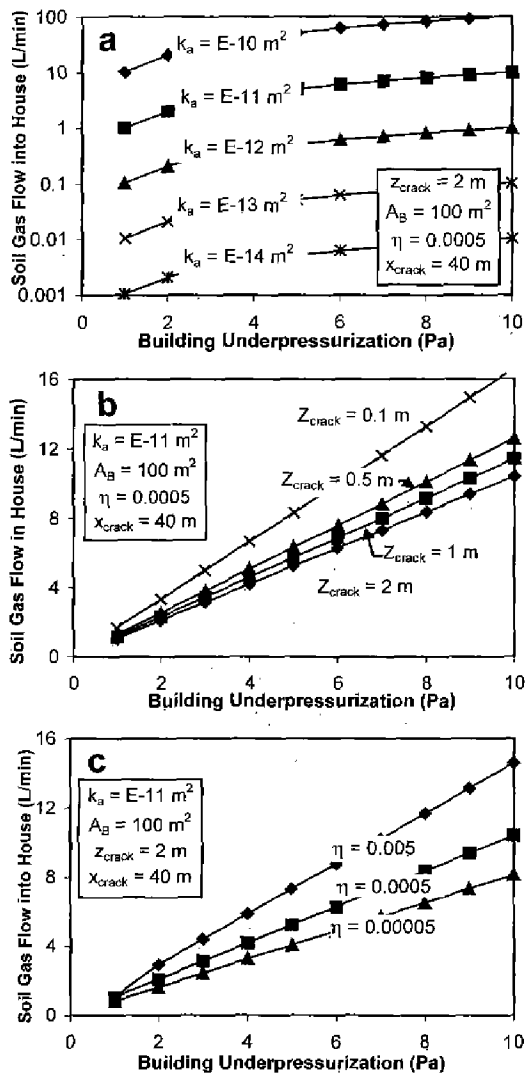

Figure 2. Sensitivity of soil gas flow to perimeter crack model (used in J&E model) to (a) soil-air permeability (k_a), (b) depth to perimeter crack (z_{crack}), and (c) crack ratio (η). X_{crack} = perimeter crack length, A_B = subsurface foundation area.

$$\eta = \frac{r_{crack} X_{crack}}{A_B} \quad (3)$$

where A_B is the subsurface foundation area (L^2). The perimeter crack model accounts for both soil gas flow through soil and the foundation, but is most sensitive to the soil-air permeability based on the analysis presented in Figure 2. For the range of values chosen for k_a , η , ΔP , and z_{crack} , by far the greatest variation is obtained for k_a with the predicted Q_{soil} ranging between ~0.001 and 100 L/min.

One method of estimating soil-air permeability is to use published values for saturated hydraulic conductivity and water retention parameters for a particular soil type (EQM 2000). This method involves the following steps: (1) obtain saturated hydraulic conductivity for soil texture type (Schaap and Leij 1998); (2) estimate intrinsic permeability from saturated hydraulic conductivity; (3) estimate effective total fluid saturation at field capacity;

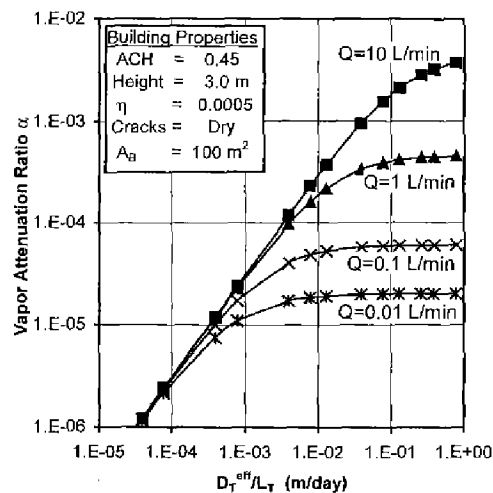

Figure 3. Sensitivity of vapor attenuation ratio (benzene) to soil-gas flow rate (Q) into building using perimeter crack model with dry dust-filled concrete cracks with total porosity = 0.3 Height = building height, $Q = Q_{soil}$ ACH = air exchanges per hour (other symbols previously defined).

(4) estimate relative air permeability using the relationship proposed by Parker et al. (1987); and (5) calculate effective soil-air permeability (relative air permeability multiplied by intrinsic permeability). The soil-air permeability can also be measured in the field (Garbesi and Sextro 1995; Hers and Zapf-Gilje 1998); however, this type of testing is rarely performed.

The Q_{soil} can also be estimated from a tracer test mass balance. When soil-gas advection is the primary mechanism for tracer intrusion into a building, the Q_{soil} can be estimated by measuring the concentrations of a chemical tracer in indoor air, outdoor air, and in soil vapor below a building, and measuring the building ventilation rate (Hers et al. 2002; Fischer et al. 1996; Garbesi et al. 1993; Rezvan et al. 1991; Garbesi and Sextro, 1989). The Q_{soil} values measured using this technique are compared to predicted rates using the perimeter crack model, for sites with coarse-grained soils (Table 1). The perimeter crack model predictions are both higher and lower than the measured values, but overall are within one order of magnitude of the measured values. Although the Q_{soil} predicted by models and measured using field tracer tests are uncertain, the results suggest that a "typical" range for houses on coarse-grained soils is on the order of 1 to 10 L/min.

J&E Model Sensitivity for Key Input Parameters

The sensitivity of the benzene α_p predicted by the J&E model is evaluated as a function of soil gas flow (Q_{soil}), the effective diffusion coefficient (D_T^{eff}), and contamination depth (L_T) (Figure 3). The D_T^{eff}/L_T ratio captures the influence of soil properties and depth to contamination source on α_p . For BTEX and most chlorinated solvent compounds, chemical-specific variation in the D_T^{eff}/L_T ratio is not significant because the free-air diffusion coefficients vary by only a factor of two, and the Henry's law constants vary by a factor of 10 (D_T^{eff}/L_T is less sensitive to H' than D_{air}). Because the effective diffusion coefficient is calculated using the Millington and Quirk (1961) relationship, the soil properties of relevance are the air-filled and total porosity. A high D_T^{eff}/L_T ratio is asso-

Table 1
Comparison of Measured and Model-Predicted Soil Gas Flow Rates Into Buildings

Site	Foundation Type	ΔP (Pa)	Subsurface Foundation Area (m ²)	Crack Ratio η	Depth to Perimeter Crack (m)	$k_{soil-air}$ (Darcy)	Soil Gas Flow Rates	
							Measured Tracer (L/min)	Predicted PCM (L/min)
Chatterton Site (Hers et al. 2000)	Slab-on-grade	30	57	0.00033	0.3	10	2.7	29
	Slab-on-grade	10	57	0.00033	0.3	10	4.2	9.6
	Slab-on-grade	10	57	0.0001	0.3	10	2.9	8.2
Alameda Site Fischer et al. (1996)	Slab-on-grade	3	50	0.0001	0.2	10	1.4	2.4
Central California Site Garbese & Sextro (1989)	Filled hollow block basement w/coating	30	128	0.0001	2.5	3	67	8.3
Ben Lomond Garbesi et al. (1993)	Experimental basement	10	26	0.00075	1.8	6	9.7	2.3
Spokane Valley Houses Revzan et al. (1991)	Poured concrete basements	5	220	0.0001	2	200	102	110

Notes: Bold print values assumed, all other values measured, ΔP = building underpressurization, PCM = Perimeter Crack model.

Table 2
Qualitative Summary of Sensitive Parameters for the J&E Model

	Building Depressurized (Advection and Diffusion)	Building Not Depressurized (Diffusion Only)
High D_T^{eff}/L_T (shallow and/or dry soil)	Q_{soil} (advection controlled)	Building foundation cracks
Moderate D_T^{eff}/L_T	Q_{soil} and moisture content (MC)	Building foundation cracks and MC
Low D_T^{eff}/L_T (deep and/or wet soil)	Moisture content (diffusion controlled)	Moisture content (MC)

Note: Indoor air concentrations are directly proportional to source concentrations, building mixing height and ventilation rate.

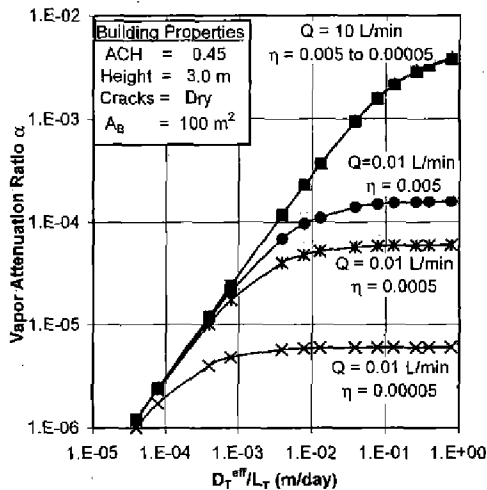

Figure 4. Sensitivity of vapor attenuation ratio (benzene) to soil-gas flow rate (Q) using perimeter crack model and foundation crack ratio (η) (other symbols previously defined).

ciated with dry soils and/or shallow contamination, whereas a low D_T^{eff}/L_T ratio is associated with wet soils and/or deep contamination. Based on the analysis in the sections that follow, sensitive parameters for the J&E model are also qualitatively summarized in Table 2.

Sensitivity of α_p to Q_{soil}

For sensitivity analysis purposes, a Q_{soil} range of 0.01 to 10 L/min was chosen because it is considered representative of most houses or small buildings. The results indicate that Q_{soil} begins to have a significant influence on α_p when D_T^{eff}/L_T values are moderate to relatively large ($> \sim 0.001$ m/day) (Figure 3). The J&E model is described to be advection controlled for this scenario. When D_T^{eff}/L_T is relatively small ($< \sim 0.001$ m/day), α_p is not sensitive to Q_{soil} . The J&E model is described to be diffusion controlled for this scenario. The D_T^{eff}/L_T for case studies subsequently evaluated in this paper ranged from ~ 0.002 to 0.1 m/day. For these D_T^{eff}/L_T values, the maximum error in prediction caused by a four order of magnitude variation in Q_{soil} ranges from 3X to 100X.

Sensitivity of α_p to Crack Ratio

The influence of crack ratio (η) on α_p was evaluated for two different Q_{soil} values (Figure 4). For $Q_{soil} = 10$ L/min, α_p is not sensitive to η . When $Q_{soil} = 0.01$ L/min, a two order of magnitude change in η causes up to 25X change in α_p . The sensitivity of α_p to η increases as Q_{soil} decreases, with sensitivity highest for the diffusion-only case (i.e., $Q_{soil} = 0$). The crack ratio is of little importance for smaller D_T^{eff}/L_T or $Q_{soil} > \sim 1$ L/min, which means that for the majority of sites crack ratio will not be important.

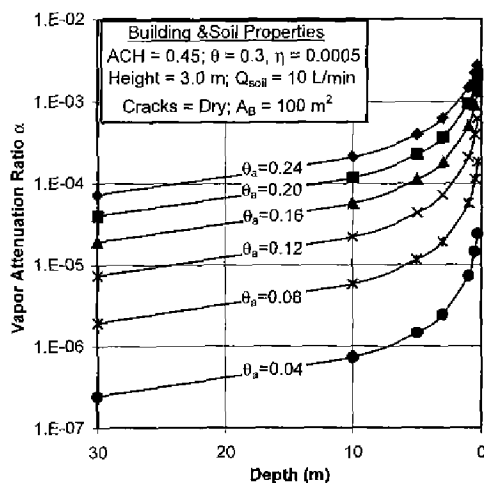

Figure 5. Sensitivity of vapor attenuation ratio (benzene) to water-filled porosity (θ_a). Other symbols previously defined.

Sensitivity of α_p to Air-Filled Porosity (Moisture Content)

The effect of air-filled porosity and depth to contamination was evaluated for a soil with moisture contents ranging from 3.6% to 15.6% (dry weight) and a constant total porosity of 0.3 (Figure 5). This variation in moisture content is potentially representative of the difference between a dry soil below a building compared to a wet soil within the capillary transition zone. The corresponding air-filled porosities are between 0.04 and 0.26. A Q_{soil} value of 10 L/min was assumed. For a constant depth to contamination, a 4X change in moisture content causes approximately or more than two orders of magnitude change in α_p . For a constant moisture content, α_p becomes sensitive to depth to contamination, at shallow depths. It is clear that soil layers with high moisture content will have a significant effect on the diffusive flux and vapor intrusion.

J&E Model Uncertainty for Range of Values

Vapor attenuation ratios predicted by the J&E model are provided for a range of soil gas advection rates and building properties, as a function of D_T^{eff}/L_T (Figure 6). For illustrative purposes, upper and lower soil-gas advection rates were estimated for four U.S. SCS soil textures (sand, loamy sand, sandy loam, and silt) using published values for saturated hydraulic conductivity and the perimeter crack model. The soil type only applies to soil immediately adjacent to the building, because the radius-of-influence for soil-gas advection is relatively limited. The estimated Q_{soil} values are highly uncertain; however, we note that the predicted values for sand (1 to 10 L/min) are consistent with the results of tracer tests for coarse-grained soils. The uncertainty in Q_{soil} increases for finer-grained soils because the influence of permeable soil layers and preferential pathways (e.g., utility backfill) becomes more important. It is suggested that the Q_{soil} for sand be used when near the foundation soil is not well characterized.

The building properties input to the model are the crack ratio, dust-filled crack moisture content, building height, building air exchanges, and building foundation size. The upper and lower building properties given are subjectively considered to represent the range of values that would be encountered at most

sites, based on available information and the author's experience (Hers and Zapf-Gilje 1998; Hers et al. 2001). The subsurface foundation area is for a house with a shallow basement or slab-on-grade foundation. Slightly lower α_p 's would be predicted for a deep basement with larger foundation area.

The graphs in Figure 6 illustrate the effect of variation in Q_{soil} and building properties on vapor attenuation ratio, but do not address uncertainty in D_T^{eff}/L_T , which is primarily caused by soil moisture content. To gain insight into uncertainty in model predictions owing to moisture content, a possible range in D_T^{eff}/L_T was evaluated for two hypothetical scenarios. The first scenario (Site 1) assumes a shallow soil vapor source (1.5 m depth) situated well above the water table. The second scenario (Site 2) assumes a relatively deep water table (6 m depth) and contamination that is limited to a dissolved ground water plume. Both sites were assumed to have uniform SCS loamy sand soil. The approach taken was to first obtain a plausible best estimate, and upper and lower range for D_T^{eff}/L_T . For Site 1, a constant air-filled porosity halfway between the residual water content and field capacity was assumed. For Site 2, the simplified VG method was used to estimate the air-filled and total porosity for the capillary zone. As shown in Table 3, the resulting porosities are expressed as relative water saturation values where $S = \theta_w/\theta$ and $\theta_a = \theta(1-S)$. The reason for using relative saturation values in the uncertainty analysis is that the air-filled and total porosity are expected to be strongly correlated. Therefore, uncertainty would be overestimated if these parameters are allowed to vary independently. This is prevented through the use of the relative saturation values. The uncertainty ranges given for total porosity and relative saturation are considered reasonable values for a well-characterized site.

Using the best estimate values and uncertainty ranges, the best estimate, lower and upper ranges are provided for the normalized effective diffusion coefficient (D_T^{eff}/L_T) (Table 3 and Figure 6). For Site 1, the upper and lower D_T^{eff}/L_T values vary by a factor of 2.4. For Site 2, the uncertainty is greater (factor of 23) because the sensitivity of D_T^{eff}/L_T to air-filled porosity within the capillary zone is high because moisture content is also high.

The overall uncertainty in the vapor attenuation ratio will be dependent on the available data. If there is information only on the contamination depth, the range in α_p can vary three to four orders of magnitude. When information on soil properties is also available, the uncertainty in D_T^{eff}/L_T and Q_{soil} is reduced resulting in α_p that vary over two orders of magnitude (Figure 6). When good quality site-specific data is available for both soil properties (e.g., moisture content) and building properties (e.g., ventilation rate, mixing height), it may be possible to reduce the uncertainty in α_p to approximately one order of magnitude.

Field-Based Methods for Evaluation of Vapor Intrusion

Three field-based approaches or methods are used to evaluate vapor intrusion: the indoor VOC method, the tracer method, and the flux chamber method. The indoor VOC method involves measurement of VOC concentrations in indoor air and at the contamination source. The α_m will vary depending on the contamination scenario. For sites with dissolved ground water plumes, the α_m is calculated using a

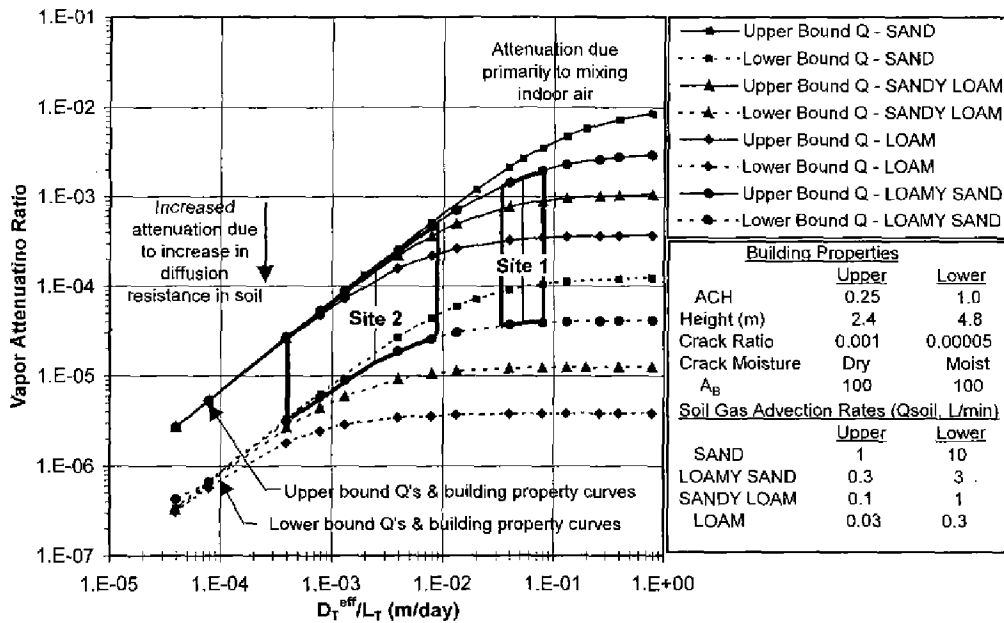

Figure 6. Predicted vapor attenuation ratio (benzene) for vapor concentrations at source and indoor air using Johnson and Ettinger (1991) model. Figure adapted from Johnson et al. (1998). Dry dust-filled cracks: Total porosity = 0.3; moist dust-filled cracks: water-filled porosity = 0.1, and total porosity = 0.3.

Parameters	Best Estimate Values		Uncertainty
	Site 1	Site 2	
Input Parameters			
Contamination	Above WT	Dissolved in Gdw	N/A
Contamination depth (m)	1.5	6.0	constant
U.S. SCS soil classification	Sandy Loam	Sandy Loam	N/A
Total porosity (θ)	0.390	0.390	+/- 10%
$S_R (\theta_v/\theta)$ above CZ (S)	0.265	0.265	+/- 25%
Height of CZ (L_{cz}) (m)	N/A	0.250	+/- 25%
$S_R (\theta_v/\theta)$ in CZ (S_{cz})	N/A	0.821	+12/-10%
Calculated Values			
D_T^{eff}/L_T lower est. (m/day)	0.0325	0.00038	
D_T^{eff}/L_T best est. (m/day)	0.0512	0.00248	
D_T^{eff}/L_T lowest est. (m/day)	0.0775	0.00861	
D_T^{eff}/L_T upper/lower range	2.4	23	

Notes: CZ = capillary zone, S_R = relative saturation, Gdw = Ground water, WT = water table.

predicted source vapor concentration (i.e., directly above the water table) estimated using the Henry's law constant assuming equilibrium partitioning between the dissolved and vapor phases. When measured source vapor concentrations are available, the α can be directly calculated. Because some deviation from equilibrium conditions would be expected, the α_m estimated using ground water and soil vapor data are not directly comparable. A key challenge for this approach is that there are numerous other "background" sources of VOCs in indoor and outdoor air for most chemicals of concern at contaminated

sites (Hers et al. 2001). The intrusion of soil vapor into buildings is also highly dependent on site-specific conditions and may vary over time. These factors complicate the interpretation of indoor air measurements when the goal is to deduce the subsurface-derived component.

The *tracer method* involves measurement of the indoor air concentration of a tracer injected below ground (SE_g), or a natural tracer such as radon (Fisher et al. 1996; Garbesi et al. 1993). The measured vapor intrusion for the tracer is, in turn, used to infer intrusion for the VOC of interest. Key factors affecting this approach are that boundary conditions for a tracer injected below a building may be different than those for the VOC of interest (e.g., if contamination is relatively deep) and that typically, an essentially inert tracer is used. When compared to the tracer, the mass loss or attenuation through sorption and/or biodegradation will be greater for most VOCs of interest. For these reasons, the tracer method will typically provide a conservative estimate of intrusion.

The *flux chamber* method involves measurement of soil-gas flow and/or VOC flux through cracks or openings in a building foundation. There are only a few published reports documenting the use of flux chambers to measure VOC flux into buildings (Figley and Snodgrass 1992; Hers and Zapf-Gilje 1998). Challenges for this approach are that these tests are difficult and costly to perform, and the uncertainty associated with "scaling up" the results for a small crack to an entire building.

Results and Discussion of Field Studies and Model Predictions

Indoor VOC Method

Vapor attenuation ratios are evaluated for 11 sites. The sites represent studies available to the authors with reasonable quality field data, and are for residential houses, ground-floor

Table 4
Measured and Model-Predicted Vapour Attenuation Ratios

Site & Reference	Contaminant or Tracer	Building and Foundation Type	Soil Conditions	Depth (m)	Chemical	Source Concentration (ug/L)	N Indoor Air ²	α_m Stat	Measured α_m	J&E model α_p^3	Comments
Indoor VOC Method											
"Virginia (Motiva) Site", Fan and Quinn (2000)	petroleum HC, NAPL above water	SFR, basements, attached garages, cement block foundations	claystone saprolite k ~ 0.01 darcy	0.5	benzene	V: 410	13	50th	<8.3E-6	3.70E-06	
"Chatterton Site" Delta, B.C. Canada	BTX petro-chemical	research greenhouse slab-on-grade	surface silt to f. sand, underlain by	1.4	benzene toluene	V: 15,000 V: 20,000	3-4	Avg	< 5.3E-7 4.0E-07	1.3E-05 5.9E-05	C1: $\Delta P=0$ Pa, $\eta = 3.3E-4$ C1: $\Delta P=0$ Pa, $\eta = 3.3E-4$
Hers et al. (1998)	plant	poured concrete	m.sand with		toluene	V: 20,000	3-4	Avg	5.9E-07	5.9E-05	C2: $\Delta P=2.5$ Pa, $\eta = 1E-4$
Hers et al.(2000a)	NAPL above water table	2 mm edge crack	k ~ 10 darcies		benzene	V: 15,000	3-4	Avg	9.9E-05	7.8E-05	C3: $\Delta P=10$ Pa, $\eta = 1E-4$
					toluene	V: 20,000	3-4	Avg	1.3E-04	7.8E-05	C3: $\Delta P=10$ Pa, $\eta = 1E-4$
					benzene	V: 15,000	3-4	Avg	7.2E-06	8.0E-05	C4: $\Delta P=10$ Pa, $\eta = 3.3E-4$
					toluene	V: 20,000	3-4	Avg	3.4E-05	8.0E-05	C4: $\Delta P=10$ Pa, $\eta = 3.3E-4$
					benzene	V: 15,000	3-4	Avg	5.8E-06	2.9E-05	C5: $\Delta P=30$ Pa, $\eta = 3.3E-4$
					toluene	V: 20,000	3-4	Avg	2.2E-05	2.9E-05	C5: $\Delta P=30$ Pa, $\eta = 3.3E-4$
"Paulsboro Site", NJ USA, Laubacher et al. (1997)	gasoline NAPL above water table	SFR basement	sand, some silt	2.74	benzene	V: 576	15	Avg	<1.6E-6	4.3E-04	
"Alameda (Air Station) Site", CA, USA	gasoline NAPL above water table	small commercial building, slab-on-grade	sand k ~ 1 to 3 darcy	0.7 0.7	benzene iso-pentane	V: 200 V: 28,000	1 1	N/A	<9E-6 < 9E-7	2.45E-04 2.46E-04	
Fischer et al.(1996)	petroleum hydrocarbon	N/A (3 sites)	N/A	N/A	benzene	N/A	-	N/A	1E-5 to 4E-5	INS	
"Mass. DEP Sites" USA, Fitzpatrick & Fitzgerald (1996)	petroleum HC NAPL above water table	Built 50's, at-grade construction, crawl-space, large paved area	sand & gravel, discontinuous clay lenses	- 3	benzene total HC	N/A	N/A	N/A	HC-like odours -- 1E-4	INS	crawlspace conc.: benzene - 8.3 mg/m ³ , Total HC - 500 mg/m ³
"Midwest School Site" USA, Moseley and Meyer (1992)	chlorinated solvents, dissolved plume	mostly apartments, few SFRs, mostly slab-on-grade, few crawl-spaces & basements, AC mostly window units, heating natural gas, baseboard, and/or fireplaces	weathered & fractured claystone above water table	4.6	1,1 DCE 1,1 DCE TCE 1,1,1 TCA 1,1,1 TCA above 3 CS	G: 10-10,000 G: 10-10,000 G: 3-3,000 G: 10-1,000 G: 10-1,000 above 3 CS	115- 150 115- 150 115- 150	Geom 90th Geom 90th Geom 90th Geom 90th	4.8E-06 2.0E-05 1.4E-05 7.0E-05 1.7E-05 6.6E-05 1.2E-05 5.2E-05	8.6E-05 2.4E-04 ⁴	average for 3 chlorinated solvents (CS)
"CDOT HDQ Site" Colorado, USA Johnson et al. (2000)	solvents, dissolved plume	SFRs, mostly slab-on-grade, few crawl-spaces & basements, AC mostly window units, heating natural gas, baseboard, and/or fireplaces	fractured claystone above water table	4.6	1,1 DCE TCE 1,1,1 TCA 1,1,1 TCA above 3 CS	G: 10-10,000 G: 3-3,000 G: 10-1,000 G: 10-1,000 above 3 CS	115- 150 115- 150	Geom 90th Geom 90th	4.8E-06 7.0E-05 1.7E-05 6.6E-05 1.2E-05 5.2E-05	8.6E-05 2.4E-04 ⁴	average for 3 chlorinated solvents (CS)
"Redfields Site" Colorado, USA Envirogroup (1999)	chlorinated solvents, dissolved plume	SFRs, built 50's and 60's, mostly basements or crawlspaces, no combustion air intakes	clay & silt, some sand layers, mostly sand or silt near WT	6.1 to 7.3	1,1 DCE 1,1 DCE 1,1 DCE	G: 10-1,000 G: 10-1,000 G: 10-1,000	65 65 65	50th Avg 90th	1.50E-05 7.60E-05 1.20E-04	INS	α_m values for houses above plume with DCE groundwater concentration > 10 ug/L
Hamilton Site Colorado, USA (2001), unpublished	chlorinated solvents, dissolved plume	SFRs, built 50's mostly basements	primarily sand & gravel, some clay & silt layers	9.7 to 11	1,1 DCE	G: 15-30 G: 15-30	32 32	50th 90th	6.80E-05 1.40E-04	INS	Gravel at water table
"Lowry (Air Force Base) Site" Colorado, USA Versar (2000)	chlorinated solvents, dissolved	SFR: mostly basements, some crawlspaces	silty sand to silt, generally silty sand near water table	6.1 to 7	1,1 DCE TCE 1,1 DCE TCE	G: 1.4-1.9 G: 120-170 V: > 29 V: > 1,000	>50 >50 >50 >50	50th 50th 50th 50th	2.20E-05 2.20E-05 6.50E-04 7.70E-04	INS	max $G \alpha_m = 6.2E-04$ max $G \alpha_m = 1.2E-03$ max $V_{SS} \alpha_m = 8.3E-03$ max $V_{SS} \alpha_m = 1.4E-02$
"Mountain View Site" California, USA Wu (2000)	chlorinated solvents, leach-field & dissolved ⁵	SFRs, built 1998, at-grade construction with moisture vapor barrier	mostly silty/ clayey sand & gravel, some sand or silt lenses	1.5 10.7	TCE TCE	V: 84 V: 84 G: 735 G: 735	14 14 14 14	Max 2nd ⁶ Max	2.80E-04 <1.3E-5 7.80E-05 <3.6E-5	INS	α_m shallow vapour α_m groundwater, depth to groundwater = 10.7 m
"Mass. DEP Sites" USA, Fitzpatrick & Fitzgerald (1996)	chlorinated solvents	N/A (19 sites)	N/A	N/A	CS	N/A	N/A	N/A	2E-6 to 1E-1	INS	high α_m associated with highly permeable building envelopes (earthen floor, block walls & sumps)
Tracer and Flux Chamber Tests											
"Central California Site", Garbesi & Sextro (1989)	SF ₆	SFR, basement poured slab, block walls coated with asphalt	sandy loam to loamy sand, k = 0.1 to 10 darcies	sub-slab	SF ₆	N/A	N/A	N/A	- 1E-3	N/A	$\Delta P = 30$ Pa
"Alameda Site" Fischer et al. (1996)	SF ₆	small commercial, slab on-grade, concrete	sand, k = 1 to 3 darcy	sub-slab	SF ₆	N/A	N/A	N/A	2E-4 to 4E-4	N/A	$\Delta P = 3$ (estimate based on wind loading)
U.S. Sites Little et al.(1992)	radon	SFRs	N/A	sub-slab	radon	N/A	N/A	N/A	1.6E-3 ⁷	N/A	
"Spokane River Valley Sites", WA, USA, Rezvan et al. (1992)	radon	SFRs (14), 8 houses slab-on-grade, 6 basement	highly permeable sand & gravel, k ~ 200 darcies	sub-slab	radon	N/A	N/A	N/A	~ 7.9E-3 to 4.5E-2	N/A	winter conditions, mean house volume = 500 m ³ , ACH = 0.5/hr

Notes: ¹Depth to contamination from underside of foundation slab; ²N = Number of indoor air samples tested; ³Best estimate unless otherwise noted; ⁴Upper range; ⁵Contamination likely in unsaturated zone; ⁶2nd highest α_m value; ⁷Alpha (α) estimated using mean radon content of soil combined with appropriate constant divided by radon concentration in U.S. homes (55 Bq m⁻³); ⁸N/A = not available or applicable, SFR = single family residence, SF₆ = sulphur hexafluoride; V = vapor, V_{SS} = sub-slab, G = ground water, bgs = below ground surface, HC = hydrocarbon, AC = air-conditioning, INS = insufficient data, ACH = air exchanges per hour, WT = water table, CS = chlorinated solvents.

Table 5
Input Parameter Values Used for Johnson and Ettinger (1991) Model¹

Parameter	Virginia Site	Chatterton Site	Paulsboro Site	Alameda Site	Midwest Site	CDOT HDQ Site	Redfields Site	Hamilton Site	Lowry Site	Mountain West Site
US SCS soil type used for D_T^{eff}/L_T	N/A	N/A	N/A	N/A	N/A	N/A	Loamy Sand	Sand	Loamy Sand	N/A
Depth to contamination (L_T) (m)	0.5	1.4	2.74	0.7	3.0	4.8	6.1	10.3	0.25 ¹	1.5 ²
Total porosity unsaturated zone (θ)	0.43	0.36	0.39	0.36	0.4	0.4	0.39	0.375	0.39	6.1 ³ 10.7 ³
Air-filled θ unsaturated zone (θ_a)	0.28	0.21	0.23	0.22	0.25	0.26	0.287	0.319	0.287	0.2
Height of capillary zone (L_c) (m)	N/A	N/A	N/A	N/A	N/A	0.2	0.25	0.375	0.17	0.25
Total θ capillary zone (θ_c)	N/A	N/A	N/A	N/A	N/A	0.4	0.39	0.375	0.39	0.41
Air-filled θ capillary zone ($\theta_{a,c}$)	N/A	N/A	N/A	N/A	N/A	0.08	0.07	0.12	0.07	0.1
D_T^{eff}/L_T (m/day)	0.12 ⁴	0.023 ⁴	0.014 ⁴	0.054 ⁴	0.016 ⁴	3.4E-3 ⁶	2.4E-3 ⁷	8.4E-3 ⁷	0.49 ⁸	0.013 ¹⁰
Soil-air permeability k_a (10^{-12} m ²)	0.01	10	10	3	—	N/A ¹²	—	—	—	2.4E-3 ⁹ 1.5E-3 ¹¹
Building underpressurization (Pa)	1	0, 2.5, 10, 30	5	3	—	N/A ¹²	—	—	—	—
Foundation crack ratio (η)	1.5E-03	3.3E-4 to 1E-4	1.E-04	1.E-04	—	1.E-04	—	—	—	—
x_{crack} (m)	55.9	26.8	27.6	26.8	—	N/A ¹²	—	—	—	—
z_{crack} (m)	2.0	0.3	2.13	0.2	—	N/A ¹²	—	—	—	—
Q_{soil} (L/min)	0.0016	8.2 to 29	2.8	2.2	—	10	—	—	—	—
Total θ dust-filled cracks (θ_{crack})	0.43	0.25	0.25	0.25	—	0.4	—	—	—	—
Air-filled θ dust-filled cracks ($\theta_{a,crack}$)	0.28	0.25	0.25	0.25	—	0.26	—	—	—	—
Air exchange per hour (ACH)	0.76	0.42 to 14.3	0.42	2.1	—	0.45	—	—	—	—
Building mixing height (m)	2.0	2.19	2.74	2.4	—	3.0	—	—	—	—
Subsurface building area (A_B) (m ²)	186	57	39	50	—	89	—	—	—	—

Notes: ¹Depth to sub-slab soil gas probes; ²Depth to shallow gas probes; ³Depth to ground water; ⁴Benzene; ⁵Iso-pentene; ⁶Average 1, 1 DCE, TCE and 1,1,1 TCA; ⁷1,1 DCE; ⁸DCE for sub-slab vapor source (TCE value is 0.43); ⁹DCE for ground water source (value for TCE is 2.2E-03); ¹⁰TCE for shallow vapor source; ¹¹TCE for ground water source; ¹² Q_{soil} is estimated directly; therefore x_{crack} , z_{crack} , ΔP and k_a not needed; ¹³Building foundation thickness not included since has negligible effect.

apartments, or small commercial buildings. Site characteristics and estimated input parameters are summarized, and measured and J&E model-predicted vapor attenuation ratios (α_m and α_p) are compared (Tables 4 and 5, Figure 7). In most cases, the vapor attenuation ratios are estimated by the authors using site data; in a few cases, the ratios given in references cited in Table 4 are reported. This has led to differences in the statistical estimators used to characterize the variability in α_m and α_p . For completeness, the vapor attenuation ratios reported for several Massachusetts sites are also included in Table 4; these sites are not included in the 11 case study sites discussed later.

The quality and quantity of site characterization data, and ability to distinguish measured indoor air concentrations from background VOC sources varies from site to site. For three sites, the VOC concentrations in a relatively large number of houses above the contaminant plume were significantly greater than house concentrations in background areas, resulting in fairly reliable α_m estimates. For the remaining sites, either the vapor-derived VOC concentrations in indoor air were significant in only a small subset of houses above the contaminant plume, or there was no significant difference between above plume and background indoor air concentrations. The vapor attenuation ratio is not measurable when there is no significant vapor-derived component; however, the indoor air concentrations can be used to calculate upper bound α_m values, represented as "less than" values in Table 4, and dashed lines in Figure 7.

For each site (except Chatterton), a predictive "envelope" for

α_p was generated. A best estimate D_T^{eff}/L_T was directly calculated when reasonably good quality moisture content data was available. When good quality data was not available, the U.S. SCS soil texture class was inferred based on soil descriptions and the simplified VG method was used to calculate D_T^{eff}/L_T . We recognize that inference of soil texture is approximate and subjective. The upper and lower bound D_T^{eff}/L_T values were approximated using the same variability calculated for the two hypothetical sites discussed earlier (Table 3). The upper and lower bounds for Q_{soil} and building properties are the curves presented in Figure 6. A Q_{soil} range of 1 to 10 L/min (i.e., representative of sand) was assumed for all sites (except Virginia) because either coarse soils were present below building foundations, or there was no information on soil type (in these cases, sand was assumed to be present below foundations). Based on the fine-grained near-foundation soils at the Virginia site, a Q_{soil} range of 0.03 to 0.3 L/min (i.e., representative of loam) was assumed. When there was sufficient information on building properties and soil gas advection potential, the J&E model-predicted α_p was also estimated (represented as symbols in Figure 7). For the Chatterton site, only the best estimate α_p were plotted because testing at this site involved an experimental building and test cases not representative of generalized predictive envelopes in Figure 6.

Measured Vapor Attenuation Ratios at Petroleum Hydrocarbon Sites

Case study sites with petroleum hydrocarbon contamination have coarse-grained soils (except for the Virginia site) and

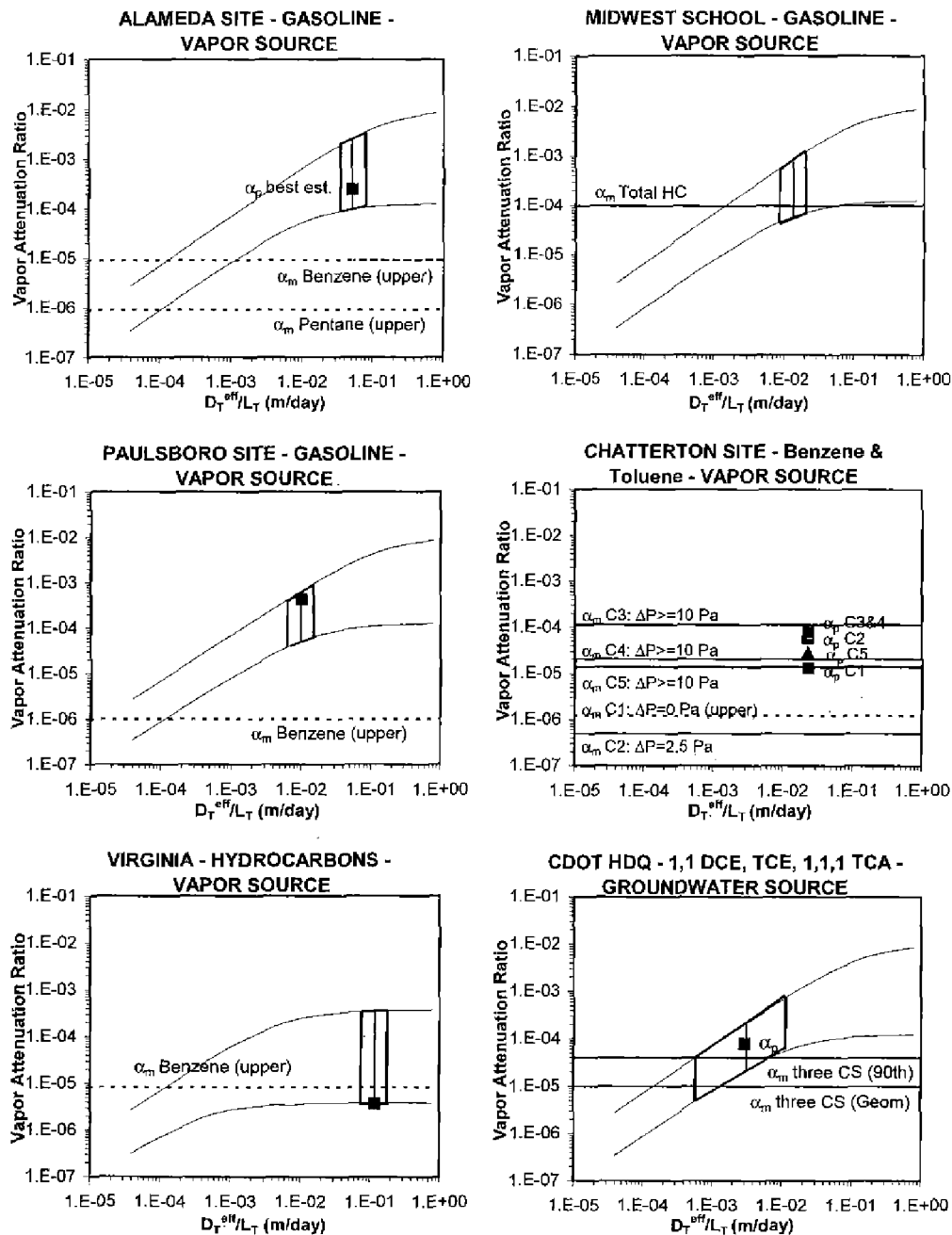

Figure 7a. Comparison between measured and J&E model-predicted vapor attenuation ratio (benzene). Upper and lower bound curves from Figure 6 are included. Dashed lines indicate that α_m is upper bound value. Symbols are best estimate α_p values.

shallow to moderate depths to contamination (0.5 to 3 m). Extensive residual nonaqueous phase liquid (NAPL) is present above the water table at the Chatterton site. There is evidence for some residual NAPL above the water table at the Alameda, Paulsboro, Virginia, and Midwest School sites. Indoor air testing was limited to a single or small number of buildings at each case study site. For petroleum sites, near-source vapor concentrations are available and therefore the α_m is directly calculated (vapor α_m).

At the Virginia, Chatterton (depressurization (ΔP) = 0 Pa case), Paulsboro, and Alameda sites, there was no difference between indoor air concentrations measured in building(s)

above the plume and in background areas, indicating that the α_m are unknown. For these sites, the α_m calculated using the measured indoor air concentrations are upper-bound values and range from $< 4.0 \times 10^{-7}$ to $< 9.0 \times 10^{-6}$. For the Chatterton $\Delta P = 2.5$ Pa case, there was a statistically significant difference in indoor and background indoor air concentrations; however, the α_m remained low (4.0×10^{-7} to 5.9×10^{-7}). For the Chatterton $\Delta P = 10$ and 30 Pa cases, there was a significant increase in indoor air concentrations and α_m .

At the Midwest School site, hydrocarbon-like odors were noted indoors during a period of relatively heavy rains and high water table in September 1992. Subsequent analysis of indoor

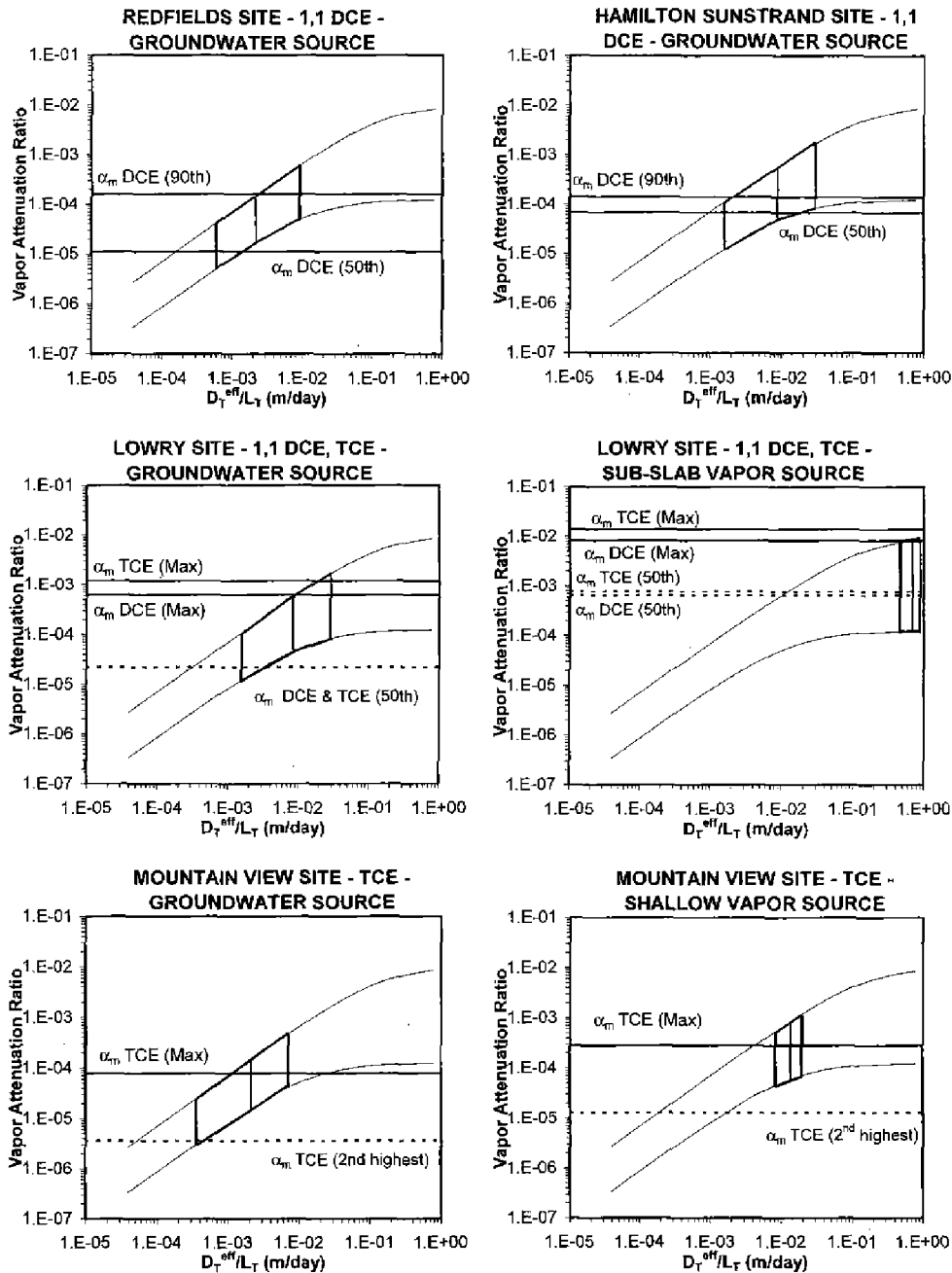

Figure 7b. Comparison between measured and J&E model-predicted vapor attenuation ratio (benzene). Upper and lower bound curves from Figure 6 are included. Dashed lines indicate that α_m is upper bound.

air during October 1992 indicated that hydrocarbon concentrations in indoor air were elevated but could not be conclusively distinguished from background sources at this time. However, the benzene (8 mg/m^3) and total hydrocarbon concentrations (500 mg/m^3) in an unventilated crawlspace below the ground floor were well above background levels. Based on a rough estimate of the source vapor concentrations and odor thresholds for hydrocarbons, the α_m may have been on the order of 1×10^{-4} .

Field data, including soil vapor profiles, indicate there was significant bioattenuation of hydrocarbon vapors for the Alameda and Chatterton ($\Delta P = 0$ and 2.5 Pa cases) sites. This

is consistent with other studies indicating that biodegradation can result in significant vadose zone attenuation of hydrocarbon vapors, provided sufficient O_2 is present (Ostendorf and Kampbell 1991; Ririe and Sweeney 1995). For higher underpressurizations (10 and 30 Pa), at the Chatterton site hydrocarbon vapor concentrations were elevated because of increased vapor flux from deeper soil, and reduced travel times (Hers et al. 2002). The relatively high α_m at the Chatterton site are from the combined effect of shallow contamination, relatively permeable soils, and high building underpressurizations.

The Paulsboro and Midwest School sites had elevated

hydrocarbon vapor levels directly below the building slab. For the Midwest School site, we speculate that elevated indoor hydrocarbon concentrations may have been a result of limited biodegradation owing to a large building and paved area, which reduced oxygen recharge, combined with factors that contributed to vapor intrusion into the building. These factors include building construction (i.e., crawlspace) and/or a sanitary sewer that was located near the water table within the hydrocarbon plume, which may have acted as a preferential pathway. At the Virginia site, contamination was shallow but no significant vapor intrusion was measured possibly because of the presence of fine-grained soils and/or building construction (i.e., tight foundations).

Comparison to Model Predictions for Petroleum Hydrocarbon Sites

Comparisons for the Chatterton ($\Delta P = 0$ and 2.5 Pa cases), Paulsboro, and Alameda sites indicate that the best estimate α_p are one to two orders of magnitude higher than the measured or upper bound α_m indicating the J&E model results in conservative predictions for these sites. Comparisons for the Chatterton ($\Delta P = 10$ and 30 Pa cases) and Virginia sites indicate the best estimate α_p are similar to the α_m . The high soil-gas advection rates for the Chatterton site resulted in significant vapor intrusion rates and hence similar α_p and α_m . For the Virginia site, the α_p is lower than at other sites owing to the influence of the fine-grained soils. For the Midwest site, the predictive envelope for α_p also intersects the α_m ; however, the α_m is highly uncertain.

Measured Vapor Attenuation Ratios at Chlorinated Solvent Sites

At four case study sites with chlorinated solvent contamination (CDOT, Redfields, Hamilton, and Lowry), dissolved plumes have migrated below houses (Table 4). The depth to the water table at these sites ranged from ~4.8 to 10.7 m below ground surface. The ground water plumes at these sites are relatively long and narrow, resulting in significant spatial variability in dissolved ground water concentrations. At the fifth site (Mountain View), houses were constructed on top of a former leach field where chlorinated solvents had been disposed of. Therefore, in addition to ground water, shallow soil is likely contaminated at this site. Soil grain size at the sites is variable (Table 4). For all sites, the α_m are estimated using vapor concentrations predicted from ground water data (ground water α_m). For the Lowry and Mountain View sites, soil vapor data were also available; therefore, the α_m is also directly calculated using vapor data (unless otherwise noted, the α_m given below are for the ground water source scenario).

For the CDOT site, the differences in three chlorinated solvent concentrations (1,1 DCE, TCE, and 1,1,1 TCA) in houses above the plume and at background locations are statistically significant. However, the ground water and indoor air data were found to be unreliable at the periphery of the plume and therefore low ground water and indoor air concentrations were removed from the database prior to calculating the α_m . The resulting database comprises several hundred tests from apartments and houses. The methodology used to estimate α_m is further described in Johnson et al. (2000). The geometric mean and 90th percentile α_m for the CDOT site are 1.0×10^{-5} and 5.2×10^{-5} . Analysis of the intrusion database for the site indi-

cated no strong correlation between seasons and α_m , or difference between basement and slab-on-grade construction (personal communication, Dr. Jeff Kurtz, EMSI Inc.).

For the Redfields site, the difference in 1,1 DCE concentrations in houses above the plume and at background locations are statistically significant. A data screening procedure similar to that used for the CDOT site resulted in α_m only being estimated in areas where the 1,1 DCE concentrations in ground water exceeded 10 $\mu\text{g/L}$. A visual interpolation method was used to estimate ground water concentrations below houses. The resulting database comprises 65 houses nearest to the Redfields site. The 50th and 90th percentile α_m for the Redfields site are 1.1×10^{-5} and 1.2×10^{-4} . Synoptic data for the Redfields site indicated a slight correlation between indoor 1,1 DCE concentrations and season, for some houses, with winter-time values that were two to three times higher than summer-time values (personal communication, Dr. David Folkes 2000).

For the Hamilton site, the difference in 1,1 DCE concentrations in houses above the plume and at background locations are statistically significant. Because ground water data was limited, the attenuation ratio analysis is for a strip of 32 houses parallel and closest to the long axis of the plume (and wells) in the area with 1,1 DCE concentrations above ~10 $\mu\text{g/L}$. The 50th and 90th percentile α_m for the Hamilton site are 6.8×10^{-5} and 1.4×10^{-4} .

At the Lowry site, the database evaluated consists of more than a year of quarterly testing at 13 houses above and near the periphery of the plume. Concurrent testing of indoor air, and subslab vapor concentrations for houses with slab-on-grade or basement construction, and crawlspace air for houses with crawlspaces was conducted. At one house, the maximum TCE and 1,1 DCE concentrations in indoor air were 51 $\mu\text{g/m}^3$ and 0.91 $\mu\text{g/m}^3$, suggesting significant vapor intrusion. At three other houses, the TCE concentrations in indoor air were mostly between 5 and 15 $\mu\text{g/m}^3$. Compared to published background data for TCE (Hers et al. 2001) and data for houses along the periphery of the plume, it is possible that concentrations at these three houses included a soil vapor-derived component. The indoor air concentrations were at background levels in remaining houses.

Measured vapor attenuation ratios are estimated for a subset of four Lowry houses with nearby ground water data. For this data subset, the maximum indoor air TCE concentration was 51 $\mu\text{g/m}^3$, but exceeded 5 $\mu\text{g/m}^3$ in only one house. Therefore, most α_m are upper bound values. When all data are used, the 50th percentile and maximum ground water α_m are 2.2×10^{-5} and 1.2×10^{-3} for TCE, and 2.2×10^{-5} and 6.2×10^{-4} for 1,1 DCE. The maximum, as opposed to 90th percentile α_m , was calculated owing to the relatively limited number of tests for this site. The Lowry subslab vapor concentrations were highly variable and elevated below certain houses (e.g., TCE up to 10,000 $\mu\text{g/m}^3$), but near background levels below other houses above the plume. An analysis of the house data subset where indoor air TCE concentrations exceeded 5 $\mu\text{g/m}^3$ and/or subslab TCE concentrations exceeded 1000 $\mu\text{g/m}^3$ indicated that the 50th percentile and maximum subslab vapor α_m are 7.7×10^{-4} and 1.4×10^{-2} . Available synoptic data for the Lowry site indicated no significant seasonal variation in subslab or indoor air concentrations.

At the Mountain View site, indoor air in seven houses

above the contaminated area and two "background" houses in a noncontaminated area was tested on two occasions. The indoor TCE concentration in one house was 12 and 25 $\mu\text{g}/\text{m}^3$, whereas the TCE concentrations in remaining houses were at background levels (0.26 to 1.1 $\mu\text{g}/\text{m}^3$) (Wu 2000). The maximum ground water α_m is 7.8×10^{-5} while the shallow vapor maximum α_m is 2.8×10^{-4} .

When all five sites are evaluated, the results can be summarized as follows. The 50th percentile (or geometric mean) and 90th percentile (or maximum) α_m values for the ground water to indoor air pathway were remarkably similar for all sites (approximately 1×10^{-5} and 1×10^{-4} , respectively). For individual sites, there is significant house-to-house variability in α_m (e.g., two order of magnitude difference for Redfields site); however, based on the available data there appear to be only slight, if any, seasonally induced variations in vapor intrusion, and similar intrusion rates for houses with basement and slab-on-grade construction. Potential sources of variability in α_m include inaccurate estimation of water table ground water concentrations below houses, geological heterogeneity, differences in house construction and depressurization, and differences in ventilation rates and house activities during indoor air testing. At the Lowry and Mountain View sites, no significant vapor intrusion could be measured for most houses. One likely reason for the generally nonsignificant intrusion is that ground water concentrations are lower at these sites, compared to the CDOT, Redfields, and Hamilton sites. Another possible factor for the Mountain View site is the building construction, which consists of at-grade foundation slab with (moisture) vapor barrier. Overall, the results suggest that geologic conditions and diffusion rates have the greatest influence on vapor intrusion rates at the chlorinated solvent sites, and that building factors are less important.

Comparison to Model Predictions for Chlorinated Solvent Sites

Comparisons for sites with the most reliable data (CDOT, Redfields, and Hamilton) indicates that the predictive envelope for the α_p intersects the α_m . The centroid of the predictive envelope is in all cases higher than the 50th percentile α_m suggesting, on average, the J&E model would result in conservative predictions. For the CDOT site, the best estimate α_p is approximately eight times higher than the 50th percentile α_m . For the Lowry site, the predictive envelope is below the α_m for one house with significant vapor intrusion, indicating a non-conservative prediction in this case. For the Mountain View site, the predictive envelope for α_p intersects the maximum α_m . Overall, the J&E model in most cases results in conservative predictions (i.e., α_p is higher than α_m). However, the comparisons highlight the potential for nonconservative predictions if a combination of low Q_{soil} and low D_T^{eff}/L_T are used.

Tracer Method

There are several sites where tracer tests can be used to estimate α , which range from $\sim 2 \times 10^{-4}$ at the Alameda site to 4.5×10^{-2} at the Spokane River (Valley) sites (Table 4). The Spokane River sites were calculated using an assumed average house volume (500 m^3) and building ventilation rate (air changes per hour (ACH) = 0.5 hour^{-1}) and therefore are approximate. Soils at the Spokane River site are very permeable, and α is based on winter conditions (i.e., highest expected

seasonal building depressurization); therefore, the α for this site is considered an upper range value. It should be remembered that tracer studies represent α values for near-field boundary conditions and, therefore, are not representative of intrusion at many sites contaminated with VOCs. The tracer test α values are, however, consistent with the upper range of the J&E model predictions (Figure 6).

Flux Chamber Method

A method that has been used for radon assessments is the equivalent leakage area (ELA) method (Grimsrud et al. 1982; CSGB 1986). The ELA is obtained by developing an empirical relationship between the soil-gas flow into a building and building depressurization. Soil-gas flows are measured using flux chambers and mass flow meters. In one study involving multiple measurements of soil-gas flow through various building foundation cracks at 10 houses in Saskatchewan, Canada, the total house foundation ELA for the foundation edge cracks and utility penetrations ranged from 0.15 to 16.4 cm^2 (Figley and Snodgrass 1992). The contribution to total ELA from untrapped floor drains, present at a few houses, was excluded from this analysis since untrapped drains are uncommon in newer construction. For example, the National Building Code of Canada (1995) requires sealing of floor drainage systems that have the potential to allow soil-gas entry (Section 9.13.8.3).

The measured total ELA can be used to estimate soil-gas intrusion rates using the method in Figley (1997). A building depressurization representative of severe winter conditions (10 Pa), as proposed by Figley (1997), and possible values for the house volume (500 m^3) and building ventilation rate (0.3 ACH) produces α values between 3.6×10^{-4} and 3.8×10^{-2} . The α obtained in this manner is conservative because it assumes an unlimited and uniform soil-vapor source directly below the foundation slab (i.e., contaminants in vapor are replenished as fast as they are swept into the building).

Flux chamber tests have also been used to measure VOC flux rates through concrete cracks (Schmidt and Zdeb 1997; Hers and Zapf-Gilje 1998). Both studies indicated detectable VOCs were measured in soil gas transmitted through cracks, and the study by Hers and Zapf-Gilje (1998) indicated that the scaled-up flux for the entire building was of the same order as flux measured by the indoor VOC method.

Regulatory Implications

The J&E model is widely used for regulatory and guidance purposes in North America. Several agencies have developed generic screening criteria for the vapor intrusion pathway (Massachusetts 1993; Michigan 1998; Connecticut 1998). Semigenic soil standards have been developed in Canada, based on two soil types (fine- and coarse-grained) and two building types (CCME 2000). Guidance recently developed by the U.S. EPA consists of a multitiered framework to evaluate the soil vapor intrusion pathway (U.S. EPA 2002). A primary (initial) screening step is used to identify sites with significant potential for vapor intrusion (e.g., odors, product in sumps or directly below foundation), and where indoor air monitoring and/or engineering controls is warranted. A secondary screening step involves the use of semigenic curves for α , based

on soil type and depth, and target breathing concentrations in indoor air to back-calculate acceptable source ground water and soil vapor concentrations. Depending on the results of the secondary screening, there is the option to conduct a site-specific pathway assessment.

Derivation of regulatory criteria requires the prediction of cross-media transfer of contaminants, and vapor transport and intrusion into buildings. For the regulatory agencies cited previously (excluding Massachusetts), cross-media transfer between VOCs in ground water and soil vapor is predicted using the Henry's law constant assuming equilibrium partitioning. Under the Massachusetts guidance, the Henry's law constant is divided by 10 to account for source vapor concentrations that are typically lower than those predicted assuming equilibrium partitioning. The vapor attenuation ratios incorporated into regulatory criteria depend on whether the assumed contamination scenario is a dissolved ground water plume or an unsaturated zone contamination source. For a ground water source, the α incorporates vapor transport through both the capillary transition zone and unsaturated zone. For an unsaturated zone source, the α incorporates transport through just the unsaturated zone. For the agencies cited previously, the ground water source α ranges from 4.6×10^{-6} to 1.5×10^{-3} whereas the vapor source α ranges from 3.9×10^{-7} to 6.2×10^{-3} . An analysis of the previous regulatory criteria indicates that the key factor affecting the α is the Q_{soil} value chosen or estimated for predictive purposes. Of lesser importance is the assumed generic or semigenic soil type.

When vapor attenuation ratios incorporated in regulatory criteria are compared to measured ratios for field studies presented in this paper, it is apparent that the low end of the regulatory range may not be conservative for some sites. Of greatest concern would be sites with nonbiodegradable chemicals, shallow to moderate depth contamination, and high advection potential (i.e., coarse soil, high building under-pressurization).

Conclusions and Recommendations

A comprehensive evaluation of the J&E model characteristics and sensitivity, and comparisons of measured to model-predicted vapor attenuation ratios (α_m and α_p), have been provided for residential houses, ground-floor apartments, and small commercial buildings. Based on this analysis, the following conclusions can be drawn:

1. The J&E model is moderately too highly sensitive to soil-gas advection rate into the building (Q_{soil}), at D_T^{eff}/L_T values above $\sim 1 \times 10^{-3}$. Except when Q_{soil} is low, the J&E model is relatively insensitive to building foundation properties. At best, the range or uncertainty in J&E model predictions is about one order of magnitude when relatively good quality site-specific data is available.
2. Estimation of effective diffusion coefficient is subject to considerable uncertainty. Some of this uncertainty can be reduced through better site characterization, including careful lithological descriptions, testing of moisture content, grain size distribution and water retention, and appropriate consideration of the effect of surface barriers on soil moisture content.
3. Several radon and VOC tracer studies indicate that measured Q_{soil} values at coarse-grained soil sites, for single fam-

ily residences, ranged from ~ 1 to 10 L/min. Depending on the input values chosen, much lower Q_{soil} values can be predicted using the soil-gas advection model typically used in conjunction with the J&E model.

4. There are only a limited number of high quality and comprehensive field studies that can be used to help validate models for the vapor intrusion pathway.
5. For petroleum hydrocarbon sites, the vapor α_m for the Chatterton site (high ΔP cases) and Midwest site were on the order of 1×10^{-5} to 1×10^{-4} (the Midwest value is uncertain). For the remaining cases and sites, the possible upper bound vapor α_m ranged from $\sim 5 \times 10^{-7}$ to 1×10^{-5} .
6. For chlorinated solvent sites, the ground water α_m were on the order of 1×10^{-6} to 1×10^{-4} for the three sites with the most reliable data sets (CDOT, Redfields, and Hamilton). For one site with a smaller and somewhat less reliable data set (Lowry), the maximum ground water α_m was $\sim 1 \times 10^{-3}$ while the maximum subslab vapor α_m was $\sim 1 \times 10^{-2}$.
7. For the tracer and flux chamber studies, the α_m was on the order of 1×10^{-4} to 1×10^{-2} . In the context of VOC intrusion, these α_m represent conservative upper bounds owing to boundary conditions and tracer properties that are generally different than those at VOC-contaminated sites.
8. For almost all case studies, the best estimate J&E model-predicted α_p were one to two orders of magnitude less than the 50th percentile or median α_m , indicating that when best estimate and average conditions are evaluated, the J&E model predictions are conservative. There were a few cases studies where the best estimate α_p was less than the 90th percentile or maximum α_m , indicating the J&E model predictions are nonconservative for a small subset of houses or apartments. The comparisons also highlight the potential for non-conservative model predictions if a combination of low Q_{soil} and low D_T^{eff}/L_T are used.

The observed variability in α_m between different field sites, and individual houses at some sites, highlights the complexity of processes affecting vapor intrusion. Numerous factors potentially affect the vapor intrusion pathway including biodegradation, chemical transformation, sorption, contaminant source depletion, geologic heterogeneity, soil properties (moisture content, permeability, organic carbon content), building properties, meteorological conditions, and building ventilation rates. In light of this complexity, it is important to recognize the vapor intrusion modeling paradigm typically followed is a compartmental model for steady-state one-dimensional diffusion through soil, and diffusion and advection through a building foundation having an idealized edge or perimeter crack (J&E model). Often, a homogeneous soil is assumed, although it is relatively easy to model diffusion for multiple soil layers assuming site information is available (Johnson et al. 1998). Simulation of vapor transport through the building foundation and mixing of VOCs within the building airspace is highly simplified. Although not used for this study, it is noted that the J&E model has been modified to include first-order biodegradation for a dominant soil layer (Johnson et al. 1998) and oxygen-limited first-order biodegradation (Johnson et al. 2001).

Notwithstanding the above, the question remains: Can the

J&E model (or other similar screening models) be reliably used for the vapor intrusion pathway? Our answer is a qualified yes, provided that appropriate input values are used and the model sensitivity, uncertainty, and limitations are recognized. The answer may also depend on what the model is used for. For example, the use of the J&E model to set generic criteria is problematic owing to model sensitivity and uncertainty, and the wide range in possible site conditions. In our opinion, a semigenetic approach that incorporates site-specific information on critical factors affecting vapor intrusion (e.g., Q_{soil} and soil properties) improves on a single criteria approach. The technically preferred approach is to use the J&E model on a fully site-specific basis, and to calibrate model predictions using soil vapor profiles, and when possible, indoor air data. In all cases, an appropriate framework for model use and understanding of model characteristics is essential when using models for regulatory purposes.

Several data gaps and sources of uncertainty remain. Additional field-based studies should be conducted to evaluate the vapor intrusion pathway for different site conditions, and to more fully assess specific factors affecting vapor intrusion. Data that would contribute to a more in-depth pathway analysis include soil properties such as moisture content and porosity, soil vapor concentration profiles below buildings, building properties such as depressurization, and meteorological data. Further evaluation of biodegradation kinetics for hydrocarbon vapors, effect of surface barriers (e.g., buildings) on biodegradation, and chlorinated solvent transformation processes are also needed.

Acknowledgments

The authors thank those persons that contributed data to this study, and acknowledge the constructive comments by the reviewers of this paper.

References

- American Society for Testing and Materials (ASTM). 1995. Standard guide for risk-based corrective action applied at petroleum release sites. E-1739-95.
- Canadian General Standards Board. 1986. Determination of the airtightness of building envelopes by the fan depressurization method. CAN/CSGB-149.10-M86.
- Canadian Council for Ministers of the Environment. 2000. Canada wide standards for petroleum hydrocarbon compounds in soil. June.
- Connecticut Department of Environmental Protection. 1998. Residential volatilization criterion. RCSA 22a-133k, Appendix E.
- EnviroGroup Limited. 1999. Indoor air assessment report—Redfield Rifle Scope Site. April.
- Environmental Quality Management Inc. 2000. User's guide for the Johnson and Ettinger (1991) model for subsurface vapor intrusion into buildings (revised). Prepared for E.H. Pechan and Associates Inc. Submitted to U.S. EPA.
- Fan, A., and E.A. Quinn. 2000. Case study: Residential indoor air assessment above a hydrocarbon plume. Presentation to U.S. EPA EI Forum, RCRA National Conference, Washington, D.C., August 15.
- Fetter, C.W. 1994. *Applied Hydrogeology*, 3rd ed. Englewood Cliffs, New Jersey: Prentice-Hall.
- Figley, D.A., and L.J. Snodgrass. 1992. Comparative foundation air leakage performance of ten residential concrete basements. In *Proceedings of the 85th Annual Meeting of Air and Waste Management Association*, June 21-26.
- Figley, D.A. 1997. A guide for estimating indoor concentrations of soil gas pollutants in houses. Report prepared for CMHC.
- Fischer, M.L., A.J. Bentley, K.A. Dunkin, A.T. Hodgson, W.W. Nazaroff, R.G. Sextro, and J.M. Daisey. 1996. Factors affecting indoor air concentrations of volatile organic compounds at a site of subsurface gasoline contamination. *Environmental Science and Technology* 30, no. 10: 2948-2957.
- Folkes, D. 2000. Envirogroup Inc., personal communication.
- Garbesi, K., and R.G. Sextro. 1989. Modeling and field evidence of pressure-driven entry of soil gas into a house through permeable below-grade walls. *Environmental Science and Technology* 23, no. 12: 1481-1487.
- Garbesi, K., R.G. Sextro, W.J. Fisk, M.P. Modera, and K.L. Revzan. 1993. Soil-gas entry into an experimental basement: Model measurement comparisons and seasonal effects. *Environmental Science and Technology* 27, no. 3: 466-473.
- Grimsrud, D.T., M.H. Sherman, and R.C. Sonderegger. 1982. Calculating infiltration: Implications for a construction quality standard. In *Proceedings of the American Society of Heating, Refrigeration, and Air-Conditioning Engineers and the U.S. Department of Energy Conference: Thermal Performance of the Exterior Envelopes of Buildings II*. Las Vegas, Nevada, December.
- Hers, I., and R. Zapf-Gilje. 1998. Canadian consortium research project: Field validation of soil gas transport to indoor air pathway. In *Proceedings of the 1998 Petroleum Hydrocarbon and Organic Chemicals in Ground Water Conference*. American Petroleum Institute/National Ground Water Association, Houston, Texas; 251-266. Westerville, Ohio: NGWA.
- Hers, I., R. Zapf-Gilje, D. Evans, and L. Li. 2002. Comparison, validation and use of models for predicting indoor air quality from soil and groundwater contamination. *Soil and Sediment Contamination* 11, no. 4: 491-527.
- Hers, I., J. Atwater, L. Li, and R. Zapf-Gilje. 2000. Evaluation of vadose zone biodegradation of BTX vapors. *Journal of Contaminant Hydrology* 46, 233-264.
- Hers, I., R. Zapf-Gilje, L. Li, and J. Atwater. 2001. The use of indoor air measurements to evaluate exposure and risk from subsurface VOCs. *Journal of the Air and Waste Management Association* 51, 174-185.
- Johnson, P.C., and R. Bittinger. 1991. Heuristic model for predicting the intrusion rate of contaminant vapors into buildings. *Environmental Science and Technology* 25, no. 8: 1445-1452.
- Johnson, P.C., W. Kembrowski, and R.L. Johnson. 1998. Assessing the significance of subsurface contaminant vapor migration to enclosed spaces: Site specific alternatives to generic estimates. API Publication 4674. Washington, D.C.: American Petroleum Institute.
- Johnson, P.C., J. Kurtz, R. Bryan, and R. Ettinger. 2000. In-depth review of Colorado (CDOT facility) data. Presentation at U.S. EPA RCRA EI Forum, August 15-16. Washington, D.C.: U.S. EPA.
- Johnson, P.C., V.A. Hermes, and S. Roggemans. 2001. An oxygen-limited hydrocarbon vapor migration attenuation screening model. Submitted to *Environmental Science and Technology*.
- Kurtz, J. 2001. EMSI Inc., personal communication, Denver, Colorado.
- Laubacher, R.C., P. Bartholomae, P. Velasco, and H.J. Reisinger. 1997. An evaluation of the vapor profile in the vadose zone above a gasoline plume. In *Proceedings of the 1997 Petroleum Hydrocarbon and Organic Chemicals in Ground Water Conference*. American Petroleum Institute/National Ground Water Association; 396-409. Westerville, Ohio: NGWA.
- Massachusetts Department of Environmental Protection. 1993. Massachusetts contingency plan (GW-2 Standards), 310 CMR 40.0000, 1993 and as amended.
- McCarthy, K.L., and R.L. Johnson. 1993. Transport of volatile organic compounds across the capillary fringe. *Water Resources Research* 29, no. 6: 1675-1683.

Michigan Department of Environment Quality (DEQ) 1998. Part 201 generic groundwater and soil volatilization to indoor air inhalation criteria: Technical support document.

Millington, R.J., and J.M. Quirk. 1961. Permeability of porous solids. *Trans. Faraday Society*, 1200-1207.

Moseley, C.L., and M.R. Meyer. Petroleum contamination of an elementary school: A case history involving air, soil-gas and groundwater monitoring. *Environmental Science and Technology* 26, no. 2: 185-192.

Nazaroff, W.W. 1992. Radon transport from soil to air. *Review of Geophysics* 30, no. 2: 137-160.

Neilson, K.K., and V.C. Rogers. 1990. Radon transport properties of soil classes for estimating indoor radon entry. In *Proceedings of 29th Hanford Symposium of Health and the Environment. Indoor Radon and Lung Cancer: Reality or Myth? Part 1*; F.T. Cross, ed. Columbus, Ohio: Battelle Press.

Ostendorf, D.W., and D.H. Kampbell. 1991. Biodegradation of hydrocarbon vapors in the unsaturated zone. *Water Resources Research* 27, no. 4: 453-462.

Parker, J.C., R.J. Lenhard, and T. Kuppusamy. 1987. A parametric model for constitutive properties governing multiphase flow in porous media. *Water Resources Research* 23, no. 4: 618-624.

Revzan, K.L., W.J. Fisk, and A.J. Gadgil. 1991. Modeling radon entry into houses with basements: Model description and verification. *Indoor Air* 2, 173-189.

Ririe, T., and R. Sweeney. 1995. Fate and transport of volatile hydrocarbons in the vadose zone. In *Proceedings of the Petroleum Hydrocarbon and Organic Chemicals in Ground Water Conference*. American Petroleum Institute/National Ground Water Association; Houston, Nov. 29-Dec. 1, 529-542. Westerville, Ohio: NGWA.

Schaap, M.G., and F.J. Leij. 1988. Database related accuracy and uncertainty of pedotransfer functions. *Soil Science* 163, 765-779.

Schmidt, C.E., and T.F. Zdeb. 1998. Direct measurement of indoor infiltration through a concrete slab using the U.S. EPA flux cham-

ber. In *Proceedings of the 1998 Air and Waste Management Association*. Paper #98, TA9C.01.

U.S. Environmental Protection Agency. 2001. Draft supplemental guidance for evaluating the vapor intrusion to indoor air pathway. OSWER. Washington, D.C.: U.S. EPA.

Van Genuchten, M.Th. 1980. A closed-form equation for predicting the hydraulic conductivity of unsaturated soils. *Soil Science Society of America Journal* 44, 892.

Versar Inc. 2000. Draft final operable unit 5-Groundwater. Ground-to-indoor air VOC migration pathway investigation report.

Waitz, M.F.W., J.I. Freijer, P. Keule, and F.A. Swartjes. 1996. The VOLASOIL risk assessment model based on CSOIL for soils contaminated with volatile compounds. Bilthoven, The Netherlands: National Institute of Public Health and the Environment.

Wu, J. 2000. Feasibility of indoor air testing (former GTB property) Mountain View, California: Case example. Presentation at U.S. EPA RCRA EI Forum, August 15-16, Washington, D.C.

Biographical Sketches

Ian Hers is completing Ph.D. studies at the University of British Columbia and is a senior consultant with Golder Associates Ltd. (ihers@golder.com) in Vancouver, British Columbia.

Loretta Y. Li is an associate professor in the Department of Civil Engineering at The University of British Columbia, with degrees from McGill University and Queen's University.

Paul C. Johnson is an associate professor and the assistant chair in the Department of Civil and Environmental Engineering at Arizona State University. His degrees are in chemical engineering, a B.S. from the University of California, Davis, and a Ph.D. from Princeton University.

Reidar Zapf-Gilje is an adjunct professor at the University of British Columbia (rzapf-gilje@shaw.ca) where he teaches graduate courses in the Department of Civil Engineering.



Order these new National Ground Water publications today!

The Hidden Sea: Ground Water, Springs, and Wells, 2nd Edition

by Francis H. Chapelle
NGWA, (2000)

The Hidden Sea tells the story of human interaction with ground water throughout history. Chapelle divides the book into three sections: the folklore of ground water, the geology of aquifers, and the environmental problems occurring as the result of ground water contamination. The 238-page book also includes tables and illustrations. Written for the general reader, *The Hidden Sea* offers an entertaining examination of the ground water resource that will be meaningful to anyone who has ever drilled a well, soaked in a mineral spring, or just wondered why the tap water smelled funny.

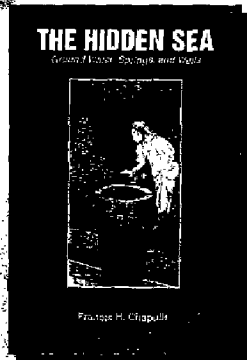

238 pages/ 2000
Reference/ #1852
Member price/ \$20.00
Prospective Member price/ \$25.00

The Compendium of Hydrogeology

by Robert Porges and Matthew Hammer



Written by practicing hydrogeologists, this inclusive handbook provides a concise, easy-to-use reference for hydrologic terms, equations, pertinent physical parameters, and acronyms.

303 pages/ 2001
Reference/ #1947
Member price/ \$25.00
Prospective Member price/ \$31.25

For additional information on these titles, or any of the other titles offered through the NGWA Bookstore, call our Customer Service Department at 1 800 551.7379, or visit us on the web at www.NGWA.org.

APPENDIX 4

EXAMPLE PRINTOUTS OF VAPOR INTRUSION MODELS

1. Soil to indoor air, residential exposure scenario.
2. Soil to indoor air, commercial/industrial exposure scenario.
3. Groundwater to indoor air, residential exposure scenario.
4. Groundwater to indoor air, commercial/industrial exposure scenario.

CALCULATE RISK-BASED SOIL CONCENTRATION (enter "X" in "YES" box)

SL-ADV
Version 2.3; 03/01

YES

OR

CALCULATE INCREMENTAL RISKS FROM ACTUAL SOIL CONCENTRATION (enter "X" in "YES" box and initial soil conc. below)

YES

	Input	Res.	C/I
IA ER:	2	1	2
EF	250	350	250
ED	25	30	25
ATnc:	25	30	25

ENTER **ENTER**
Initial
Chemical soil
CAS No. conc.,
(numbers only, C_R
no dashes) ($\mu\text{g}/\text{kg}$)

Exposure Scenario: Residential
High Permeability Soils

108383

Chemical name input not used.

MORE
↓

ENTER	ENTER	ENTER	ENTER	ENTER Totals must add up to value of L_t (cell D28)			ENTER	ENTER
Average soil temperature, T_s ($^{\circ}\text{C}$)	Depth below grade to bottom of enclosed space floor, L_f (cm)	Depth below grade to top of contamination, L_t (cm)	Depth below grade to bottom of contamination, (enter value of 0 if value is unknown) L_b (cm)	Thickness of soil stratum A, h_A (cm)	Thickness of soil stratum B, (Enter value or 0) h_B (cm)	Thickness of soil stratum C, (Enter value or 0) h_C (cm)	Soil stratum A SCS soil type (used to estimate soil vapor permeability) OR	User-defined stratum A soil vapor permeability, k_v (cm^2)
20	15	15	215	15			S	

MORE
↓

ENTER	ENTER	ENTER	ENTER	ENTER	ENTER	ENTER	ENTER	ENTER	ENTER	ENTER	ENTER
Stratum A soil dry bulk density, ρ_b^A (g/cm^3)	Stratum A soil total porosity, n^A (unitless)	Stratum A soil water-filled porosity, θ_w^A (cm^3/cm^3)	Stratum A soil organic carbon fraction, f_{oc}^A (unitless)	Stratum B soil dry bulk density, ρ_b^B (g/cm^3)	Stratum B soil total porosity, n^B (unitless)	Stratum B soil water-filled porosity, θ_w^B (cm^3/cm^3)	Stratum B soil organic carbon fraction, f_{oc}^B (unitless)	Stratum C soil dry bulk density, ρ_b^C (g/cm^3)	Stratum C soil total porosity, n^C (unitless)	Stratum C soil water-filled porosity, θ_w^C (cm^3/cm^3)	Stratum C soil organic carbon fraction, f_{oc}^C (unitless)
1.5	0.43	0.15	0.006								

MORE
↓

ENTER	ENTER	ENTER	ENTER	ENTER	ENTER	ENTER
Enclosed space floor thickness, L_{crack} (cm)	Soil-bldg. pressure differential, ΔP (g/cm^2)	Enclosed space floor length, L_B (cm)	Enclosed space floor width, W_B (cm)	Enclosed space height, H_B (cm)	Floor-wall seam crack width, w (cm)	Indoor air exchange rate, ER (1/h)
15	20	961	961	244	0.1	1

ENTER	ENTER	ENTER	ENTER	ENTER	ENTER
Averaging time for carcinogens, AT_C (yrs)	Averaging time for noncarcinogens, AT_{NC} (yrs)	Exposure duration, ED (yrs)	Exposure frequency, EF (days/yr)	Target risk for carcinogens, TR (unitless)	Target hazard quotient for noncarcinogens, THQ (unitless)
70	30	30	350	chemical specific	chemical specific

END

Used to calculate risk-based soil concentration.

CALCULATE RISK-BASED SOIL CONCENTRATION (enter "X" in "YES" box)

SL-ADV
Version 2.3; 03/01

YES

OR

CALCULATE INCREMENTAL RISKS FROM ACTUAL SOIL CONCENTRATION (enter "X" in "YES" box and initial soil conc. below)

YES

	Res.	C/I
IA ER:	1	2
EF	350	250
ED	30	25
ATnc:	30	25

ENTER **ENTER**
Initial
Chemical soil
CAS No. conc.,
(numbers only, C_R
no dashes) ($\mu\text{g}/\text{kg}$)

Exposure Scenario: Commercial
High Permeability Soils

108383
Chemical ID input not used.

MORE
↓

ENTER	ENTER	ENTER	ENTER	ENTER Totals must add up to value of L_i (cell D28)			ENTER	ENTER
Average soil temperature, T_S ($^{\circ}\text{C}$)	Depth below grade to bottom of enclosed space floor, L_F (cm)	Depth below grade to top of contamination, L_i (cm)	Depth below grade to bottom of contamination, (enter value of 0 if value is unknown) L_b (cm)	Thickness of soil stratum A, h_A (cm)	Thickness of soil stratum B, (Enter value or 0) h_B (cm)	Thickness of soil stratum C, (Enter value or 0) h_C (cm)	Soil stratum A SCS soil type (used to estimate soil vapor permeability)	OR User-defined stratum A soil vapor permeability, k_v (cm^2)
20	15	15	215	15			S	

MORE
↓

ENTER	ENTER	ENTER	ENTER	ENTER	ENTER	ENTER	ENTER	ENTER	ENTER	ENTER	ENTER
Stratum A soil dry bulk density, P_b^A (g/cm^3)	Stratum A soil total porosity, n^A (unitless)	Stratum A soil water-filled porosity, θ_w^A (cm^3/cm^3)	Stratum A soil organic carbon fraction, f_{oc}^A (unitless)	Stratum B soil dry bulk density, P_b^B (g/cm^3)	Stratum B soil total porosity, n^B (unitless)	Stratum B soil water-filled porosity, θ_w^B (cm^3/cm^3)	Stratum B soil organic carbon fraction, f_{oc}^B (unitless)	Stratum C soil dry bulk density, P_b^C (g/cm^3)	Stratum C soil total porosity, n^C (unitless)	Stratum C soil water-filled porosity, θ_w^C (cm^3/cm^3)	Stratum C soil organic carbon fraction, f_{oc}^C (unitless)
1.5	0.43	0.15	0.006								

MORE
↓

ENTER	ENTER	ENTER	ENTER	ENTER	ENTER	ENTER
Enclosed space floor thickness, L_{crack} (cm)	Soil-bldg. pressure differential, ΔP ($\text{g}/\text{cm-s}^2$)	Enclosed space floor length, L_B (cm)	Enclosed space floor width, W_B (cm)	Enclosed space height, H_B (cm)	Floor-wall seam crack width, w (cm)	Indoor air exchange rate, ER (1/h)
15	20	961	961	244	0.1	2

ENTER	ENTER	ENTER	ENTER	ENTER	ENTER
Averaging time for carcinogens, AT_C (yrs)	Averaging time for noncarcinogens, AT_{NC} (yrs)	Exposure duration, ED (yrs)	Exposure frequency, EF (days/yr)	Target risk for carcinogens, TR (unitless)	Target hazard quotient for noncarcinogens, THQ (unitless)
70	25	25	250	Chemical Specific	Chemical Specific

END

Used to calculate risk-based soil concentration.

CALCULATE RISK-BASED GROUNDWATER CONCENTRATION (enter "X" in "YES" box)

GW-ADV
Version 2.3; 03/01

YES

OR

CALCULATE INCREMENTAL RISKS FROM ACTUAL GROUNDWATER CONCENTRATION (enter "X" in "YES" box and initial groundwater conc. below)

YES

	Res.	C/I
IA ER:	1	2
EF	350	250
ED	30	25
ATnc:	30	25

Exposure Scenario: Residential
High Permeability Soils

ENTER **ENTER**
Initial
Chemical groundwater
CAS No. conc.,
(numbers only, C_w
no dashes) ($\mu\text{g/L}$)

1634044

Chemical
Xylene (m)

Chemical ID input not used

ENTER	ENTER	ENTER	ENTER	ENTER	ENTER	ENTER	ENTER	ENTER	ENTER
Average soil/ groundwater temperature, T_s ($^{\circ}\text{C}$)	Depth below grade to bottom of enclosed space floor, L_f (cm)	Depth below grade to water table, L_{WT} (cm)	Thickness of soil stratum A, h_A (cm)	Thickness of soil stratum B, (Enter value or 0) h_B (cm)	Thickness of soil stratum C, (Enter value or 0) h_C (cm)	Soil stratum directly above water table, (Enter A, B, or C)	SCS soil type directly above water table	Soil stratum A SCS soil type (used to estimate soil vapor permeability)	User-defined stratum A soil vapor permeability, k_v (cm^2)
15	15	300	100	200		B	CL	S	

ENTER	ENTER	ENTER	ENTER	ENTER	ENTER	ENTER	ENTER	ENTER
Stratum A soil dry bulk density, ρ_b^A (g/cm^3)	Stratum A soil total porosity, n^A (unitless)	Stratum A soil water-filled porosity, θ_w^A (cm^3/cm^3)	Stratum B soil dry bulk density, ρ_b^B (g/cm^3)	Stratum B soil total porosity, n^B (unitless)	Stratum B soil water-filled porosity, θ_w^B (cm^3/cm^3)	Stratum C soil dry bulk density, ρ_b^C (g/cm^3)	Stratum C soil total porosity, n^C (unitless)	Stratum C soil water-filled porosity, θ_w^C (cm^3/cm^3)
1.5	0.43	0.15	1.5	0.43	0.3			

ENTER	ENTER	ENTER	ENTER	ENTER	ENTER	ENTER
Enclosed space floor thickness, L_{crack} (cm)	Soil-bldg. pressure differential, ΔP (g/cm-s^2)	Enclosed space floor length, L_B (cm)	Enclosed space floor width, W_B (cm)	Enclosed space height, H_B (cm)	Floor-wall seam crack width, w (cm)	Indoor air exchange rate, ER (1/h)
15	20	961	961	244	0.1	1

ENTER	ENTER	ENTER	ENTER	ENTER	ENTER
Averaging time for carcinogens, AT_c (yrs)	Averaging time for noncarcinogens, AT_{NC} (yrs)	Exposure duration, ED (yrs)	Exposure frequency, EF (days/yr)	Target risk for carcinogens, TR (unitless)	Target hazard quotient for noncarcinogens, THQ (unitless)
70	30	30	350	Chemical Specific	Chemical Specific

Used to calculate risk-based groundwater concentration.

CALCULATE RISK-BASED GROUNDWATER CONCENTRATION (enter "X" in "YES" box)

GW-ADV
Version 2.3; 03/01

YES

OR

CALCULATE INCREMENTAL RISKS FROM ACTUAL GROUNDWATER CONCENTRATION (enter "X" in "YES" box and initial groundwater conc. below)

YES

	Res.	C/I
IA ER:	1	2
EF	350	250
ED	30	25
ATnc:	30	25

Exposure Scenario: Commercial
High Permeability Soils

ENTER **ENTER**
Initial
Chemical groundwater
CAS No. conc.,
(numbers only, C_w
no dashes) ($\mu\text{g/L}$)

Chemical

1634044

Xylene (m)

Chemical ID input not used.

ENTER	ENTER	ENTER	ENTER ENTER ENTER Totals must add up to value of L_{WT} (cell D28)			ENTER	ENTER	ENTER	ENTER
Average soil/ groundwater temperature, T_s ($^{\circ}\text{C}$)	Depth below grade of enclosed space floor, L_F (cm)	Depth below grade to water table, L_{WT} (cm)	Thickness of soil stratum A, h_A (cm)	Thickness of soil stratum B, (Enter value or 0) h_B (cm)	Thickness of soil stratum C, (Enter value or 0) h_C (cm)	Soil stratum directly above water table, (Enter A, B, or C)	SCS soil type directly above water table	Soil stratum A SCS soil type (used to estimate soil vapor permeability)	User-defined stratum A soil vapor permeability, k_v (cm^2)
15	15	300	100	200		B	CL	S	

ENTER	ENTER	ENTER	ENTER	ENTER	ENTER	ENTER	ENTER	ENTER
Stratum A soil dry bulk density, ρ_b^A (g/cm^3)	Stratum A soil total porosity, n^A (unitless)	Stratum A soil water-filled porosity, θ_w^A (cm^3/cm^3)	Stratum B soil dry bulk density, ρ_b^B (g/cm^3)	Stratum B soil total porosity, n^B (unitless)	Stratum B soil water-filled porosity, θ_w^B (cm^3/cm^3)	Stratum C soil dry bulk density, ρ_b^C (g/cm^3)	Stratum C soil total porosity, n^C (unitless)	Stratum C soil water-filled porosity, θ_w^C (cm^3/cm^3)
1.5	0.43	0.15	1.5	0.43	0.3			

ENTER	ENTER	ENTER	ENTER	ENTER	ENTER	ENTER
Enclosed space floor thickness, L_{crack} (cm)	Soil-bldg. floor pressure differential, ΔP (g/cm-s^2)	Enclosed space floor length, L_B (cm)	Enclosed space floor width, W_B (cm)	Enclosed space height, H_B (cm)	Floor-wall seam crack width, w (cm)	Indoor air exchange rate, ER (1/h)
15	20	961	961	244	0.1	2

ENTER	ENTER	ENTER	ENTER	ENTER	ENTER
Averaging time for carcinogens, AT_C (yrs)	Averaging time for noncarcinogens, AT_{NC} (yrs)	Exposure duration, ED (yrs)	Exposure frequency, EF (days/yr)	Target risk for carcinogens, TR (unitless)	Target hazard quotient for noncarcinogens, THQ (unitless)
70	25	25	250		

	Chemical Specific	Chemical Specific
	Used to calculate risk-based groundwater concentration.	

ND

APPENDIX 5

DEVELOPMENT OF SOIL LEACHING SCREENING LEVELS

- Massachusetts Department of Environment Protection (MADEP 1994)
- USEPA Soil Screening Level Guidance (USEPA 2002)
- Hawai'i Department of Health (HDOH 1995)

APPENDIX 6 (SEPARATE PDF FILE)

DEVELOPMENT OF CARBON RANGE AND TOTAL PETROLEUM HYDROCARBON RISK-BASED ACTION LEVELS

- Chemistry and Toxicity of Petroleum Fuels
- Chemistry and Toxicity of Petroleum Vapors (Brewer et al (2013))
- Common TPH questions (HDOH 2012)
- 2002 Massachusetts VPH-EPH Guidance
- Overview of gasoline composition (NEIWPC, 2003)
- Use of TPH Action Levels (HDOH 2024)

APPENDIX 7

DETERMINATION OF GROUNDWATER UTILITY

BENJAMIN J. CAYETANO
GOVERNOR OF HAWAII

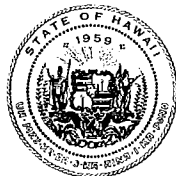

LAWRENCE MIIKE
DIRECTOR OF HEALTH

STATE OF HAWAII
DEPARTMENT OF HEALTH
ENVIRONMENTAL MANAGEMENT DIVISION
SOLID AND HAZARDOUS WASTE BRANCH
919 ALA MOANA BLVD., #212
HONOLULU, HAWAII 96814

in reply, please refer to:
EMD / SHW

September 19, 1995

POLICY UPDATE
Technical Guidance Manual
for Underground Storage Tank Closure and Release Response

Determination of Groundwater Utility
at Leaking Underground Storage Tank Sites

TO ALL INTERESTED PARTIES:

The Hawai'i Department of Health's Solid and Hazardous Waste Branch, Underground Storage Tank Section, is issuing a policy update to its *Technical Guidance Manual for Underground Storage Tank Closure and Release Response* (August 1992). **This policy update is effective September 13, 1995.**

Recommended cleanup criteria at leaking underground storage tank (LUST) sites depend on, among other things, whether the ground water underlying the site is used or intended for use as a drinking water source. This policy directs owners and operators of USTs to use the aquifer system classification reports developed by the University of Hawai'i at Mānoa's Water Resources Research Center in determining the use of the ground water underlying the site.

This new policy allows for more efficient allocation of limited cleanup resources by ensuring that cleanup requirements applied to a site are appropriate for the use of the site and the surrounding area, while at the same time maintaining effective protection of human health and the environment.

Please bring this policy update to the attention of anyone you know who may have an interest in this matter. Should you have any questions regarding this policy update, please contact the Underground Storage Tank Section at (808) 586-4226.

Sincerely,

STEVEN Y.K. CHANG, P.E., MANAGER
Solid and Hazardous Waste Branch

Attachment

**DETERMINATION OF GROUNDWATER UTILITY
AT LEAKING UNDERGROUND STORAGE TANK SITES**

Background

Soil and groundwater cleanup criteria for remedial activities pursuant to 40 CFR Part 280 Subpart F (RCRA I) and Hawai'i Revised Statutes, Chapters 342L and 128D, are based in part on the utility of the groundwater impacted or potentially impacted by the release. Cleanup criteria for release that threaten sources of drinking water are based primarily on human health concerns. Cleanup criteria for releases that threaten non-drinking water sources are based primarily on ecological/aquatic-life concerns. In general, cleanup criteria for releases that threaten drinking water are much more stringent than for those that do not.

As a useful first approximation, and in order to help maintain consistency in groundwater protection policies within the Department of Health (DOH), the SHWB informally adopted the Underground Injection Control (UIC) line as an initial demarcation between aquifer systems that serve or could potentially serve as sources of drinking water (generally beneath the inland areas of the islands) and those that could not (generally beneath the coastal areas of the islands). The UIC line was established by the DOH Safe Drinking Water Branch (working in cooperation with the Honolulu City & County Board of Water Supply, the U.S. Geological Survey, and the Water Resources Research Center of the University of Hawai'i - Mānoa, among others) for purposes of regulating the location of underground injection wells. Reference to the use of the UIC line for SHWB purposes is made in the document "Technical Guidance Manual for Underground Storage Tank (UST) Closure and Release Response (TGM, August, 1992)," prepared by the UST Section of the SHWB.

In accordance with UIC guidelines, aquifer systems mauka (inland) of the UIC line are by default considered to be current or potential sources of drinking water. Aquifer systems makai (oceanward) of the UIC line are considered by default to not be current or potential sources of drinking water. Correspondingly, cleanup criteria for release sites located mauka of the UIC line are initially set to be protective to drinking water standards. Cleanup criteria for release sites located makai of the UIC line are initially set to be protective to generally less stringent non-drinking water (surface water) standards.

Statement of Problem

The UST section of the SHWB deals with hundreds of facilities with leaking underground storage tank (LUST) sites that are required by federal and state law to report UST-related releases to DOH. Most, if not all, LUST sites are too small to technically or economically warrant a full-scale investigation of the utility of the groundwater that has been or could potentially be impacted by the release. This necessitates the use of approximated, regional groundwater-utility "zones", defined by use of such tools as the UIC line.

Numerous LUST facilities located mauka of the UIC line, however, have requested variance from use of the UIC line to approximate groundwater utility beneath their sites. The requests have been based on the known geology of the site and a position that the release does not threaten an aquifer system that currently or could potentially serve as a source of drinking water. Indeed, many of the subject sites overlie clay-rich, "caprock" coastal plain sediments that are not suitable as sources of drinking water. An extensive, subsurface investigation of the local groundwater system would likely support this at many of the sites if such an investigation was technically and economically feasible. Fortunately, recent research on aquifer systems throughout the islands addresses the bulk of these problem areas.

Aquifer Identification and Classification Technical Report Series

Since establishment of the UIC line, DOH has sponsored additional research regarding the identification, classification, and protection of groundwater resources in Hawai'i. The most important outcome of this research to date has been the "Aquifer Identification and Classification" technical report series published for each island by the Water Resources Research Center (WRRC) at the University of Hawai'i - Mānoa (see references). The reports have been incorporated into the draft Water Resources Protection Plan (March, 1992), prepared by the Department of Land and Natural Resources as part of the Hawai'i Water Plan under provisions set in Chapter 174C of the Hawai'i Revised Statutes. The DOH Office of Hazard Evaluation and Emergency Response currently uses the WRRC aquifer identification and classification reports to screen sites for prioritization.

The WRRC reports systematically review aquifer systems throughout each island and, as one element, indicate whether the aquifer system as a whole can or cannot be utilized as a source of drinking water (aquifer system "utility," second digit in aquifer system status code). Because division of the aquifer systems is based largely on geology, the WRRC aquifer classification system reports address many of the problem areas brought about by reliance on only the UIC line to approximate groundwater utility.

One of the shortcomings of the aquifer system classification reports, recognized by the authors (Mink; personal communication - Attachment A), is a lack of sufficient data to subdivide geologically-defined aquifer "types" into more narrowly-defined "units" based on the variability of groundwater quality within the aquifer system. This can be especially important in coastal areas where groundwater quality within an otherwise "drinking water" aquifer system degrades to below drinking water standards as the freshwater lens pinches out and mixes with saline water within the same geological formation. Examples include much of the basaltic coastal areas of the islands of Kaua'i, Maui, Moloka'i, and Hawai'i.

In these areas, the groundwater specialists consulted generally agreed that the UIC line can serve as a useful and valid tool for approximating the inland boundary of coastal-zone, aquifer system "units" that are not current or potential sources of drinking water (see Attachment A). Over time, continued investigation of Hawai'i's groundwater resources will naturally lead to a refinement of the boundaries between regional aquifer systems and a better breakdown of distinctive units within individual systems.

Policy Statement

Facilities with releases from USTs regulated by the UST Section of the DOH Solid and Hazardous Waste Branch must determine the utility of groundwater (generally drinking water or non-drinking water) that has been or may potentially be impacted by the release. In support of the determination of groundwater utility, the following information should be submitted to the DOH:

1. a review of the known surface and subsurface geology and hydrogeology of the site, including information gained during investigation of the release and information provided in published or unpublished reports that include the subject area (refer to TGM, August 1992 edition for information required in site investigations)
2. a description of all aquifer systems (classification, status, etc.) that have been impacted and/or could potentially be impacted by the release in accordance with the referenced aquifer system classification reports published by the WRRRC, and
3. a map showing the location of the release site with respect to the boundaries of impacted or potentially impacted aquifer systems.

In addition, if the UIC line is used to approximate the inland boundaries of coastal-zone, non-drinking water aquifer system units, then the location of the UIC line with respect to the corresponding aquifer system(s) should be included on the map and discussed in the text of the report.

DOH may request additional site-specific geologic, hydrogeologic, and other pertinent information as necessary on a site-by-site basis to make final groundwater utility determinations. In particular, facilities situated near aquifer system boundaries should evaluate the geological accuracy and applicability of the aquifer system maps to their site.

DOH reserves the right to make final decisions of groundwater utility on a site-specific basis, regardless of the location of the site with respect to regional characterizations of aquifer systems. This may become especially important in areas of extensive soil and groundwater contamination, at sites located near important aquifer system boundaries where detailed subsurface data is not available, or in ecologically sensitive areas (e.g., near bodies of surface water).

The review of an aquifer systems status as a source or potential source of drinking water will be for UST section purposes only and the results of the review should not be construed as an official confirmation or refinement of the UIC line in the area of the release site. Injection well applications, if any, will be processed according to UIC regulations, Chapter 23, by the UIC program of the Safe Drinking Water Branch (SDWB) and such applications will not be excluded from UIC restrictions due to designations of what is or is not a source of drinking water that have not been approved by the SDWB.

APPROVED/~~DISAPPROVED~~

Bruce Anderson, Ph.D., Deputy Director, Environmental Health,
Department of Health

7/13/95
Date

References:

- Environmental Response Law, Hawai'i Revised Statutes, Chapter 128D.
- Mink, J. F. and Lau, S. L., 1990, Aquifer Identification and Classification for the Island of Maui: Groundwater Protection Strategy for Hawai'i (February 1990): Water Resources Research Center, University of Hawai'i at Mānoa, Technical Report No. 185.
- Mink, J. F. and Lau, S. L., 1990, Aquifer Identification and Classification for the Island of O'ahu: Groundwater Protection Strategy for Hawai'i (February 1990): Water Resources Research Center, University of Hawai'i at Mānoa, Technical Report No. 179.
- Mink, J. F. and Lau, S. L., 1992, Aquifer Identification and Classification for the Island of Kaua'i: Groundwater Protection Strategy for Hawai'i (September 1992): Water Resources Research Center, University of Hawai'i at Mānoa, Technical Report No. 186.
- Mink, J. F. and Lau, S. L., 1992, Aquifer Identification and Classification for the Island of Moloka'i: Groundwater Protection Strategy for Hawai'i (October 1992): Water Resources Research Center, University of Hawai'i at Mānoa, Technical Report No. 187.
- Mink, J. F. and Lau, S. L., 1993, Aquifer Identification and Classification for the Island of Lanā'i: Groundwater Protection Strategy for Hawai'i (April 1993): Water Resources Research Center, University of Hawai'i at Mānoa, Technical Report No. 190.
- Mink, J. F. and Lau, S. L., 1993, Aquifer Identification and Classification for the Island of Hawai'i: Groundwater Protection Strategy for Hawai'i (May 1993): Water Resources Research Center, University of Hawai'i at Mānoa, Technical Report No. 191.
- State Water Code, Hawai'i Revised Statutes, Chapter 174C.
- Technical Guidance Manual for Underground Storage Tank Closure and Release Response (August, 1992): Hawai'i Department of Health, Solid and Hazardous Waste Branch.
- Underground Injection Control, Hawai'i Administrative Rules, Title 11, Chapter 23.
- Underground Storage Tanks, Hawai'i Revised Statutes, Chapter 342L.

APPENDIX 8

OTHER SUPPLEMENTAL REFERENCE DOCUMENTS

- Tier 2 Soil Action Levels for Arsenic (HDOH 2010a)
- Tier 2 Soil Action Levels for TEQ Dioxins (HDOH 2010b)
- Use of Laboratory Batch Tests to Evaluate Potential Leaching of Contaminants From Soil (HDOH April 2007)
- Long-Term Management of Petroleum-Contaminated Soil and Groundwater (HDOH June 2007)
- Natural Occurrence of Hexavalent Chromium in Hawai'i (HDOH January 2011)

LINDA LINGLE
GOVERNOR OF HAWAII

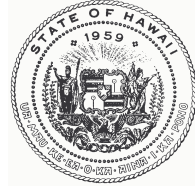

CHIYOME LEINA'ALA FUKINO, M.D.
DIRECTOR OF HEALTH

STATE OF HAWAII
DEPARTMENT OF HEALTH
P.O. Box 3378
HONOLULU, HAWAII 96801-3378

In reply, please refer to:
File: EHA/HEER Office
2010-579-RB

October 2010

To: Interested Parties

From: Roger Brewer, Ph.D., Environmental Risk Assessor, HEER

Through: Barbara Brooks, Ph.D., Toxicologist, HEER

Subject: Update to Soil Action Levels for Inorganic Arsenic and Recommended Soil Management Practices

1.0 Introduction

This technical memorandum presents an update to the 2008 Hawai'i Department of Health (HDOH) action levels and corresponding guidance for inorganic arsenic in soil (HDOH 2008a, attached). Categories for management and evaluation of arsenic-contaminated soil have been revised and simplified. Soil action levels for arsenic presented in the 2008 technical memorandum have not been adjusted. This guidance serves as an addendum to the Hazard Evaluation and Emergency Response (HEER) office document *Evaluation of Environmental Hazards at Sites with Contaminated Soil and Groundwater* (EHE guidance; HDOH 2008b).

Refer to the June 2010 dioxin technical memorandum for additional guidance on issues common to both dioxin- and arsenic-contaminated soil, including (HDOH 2010a):

- Site characterization;
- Disposal of contaminated soil;
- Engineering controls;
- Institutional controls;
- Management of Category C Soils at Commercial/Industrial Sites;
- Environmental Hazard Management Plans and management of Category C soils at commercial/industrial sites;
- Inclusion of soil above surrounding background in remediation of Category D soils; and
- Hazardous Waste Considerations.

The soil action levels presented herein are not promulgated regulatory standards or required cleanup levels. Alternative proposals may be presented in a site-specific risk assessment.

2.0 Arsenic Soil Management Categories

Updated categories for the evaluation and management of arsenic-contaminated soil are summarized below and in Table 1. These categories replace the scheme presented in the 2008 HDOH technical memorandum (HDOH 2008a):

Category A Soils (natural background): Soils exhibit concentrations of total arsenic <20 mg/kg, and do not appear to have been impacted by local, agricultural or industrial releases of arsenic; not impacted. The natural, background concentration of arsenic in soils in Hawai'i is typically less than 20 mg/kg. A summary of background concentrations of heavy metals in soil in Hawai'i is in preparation. In the interim, refer to documents published by the Air Force (USAF 2005) and Navy (USN 2006) environmental programs in Hawai'i. A summary of background concentrations of metals in various soil types on the mainland US has been published by the University of California (UCR 1996) and U.S. Geological Survey (USGS 2001).

Category B Soils (minimally impacted): Total arsenic >20 mg/kg but bioaccessible arsenic <23 mg/kg, indicating probable anthropogenic impacts but at levels within acceptable health risks for long-term exposure; Unrestricted Land Use. HEER expects Category B soils to be generally associated with agricultural fields where arsenic-based herbicides were used for weed control between the years 1915 to 1950. Arsenic levels between individual fields can vary with respect to the location of the field (e.g., high- versus low-rainfall area) as well as the weed control preferences of the sugar companies that managed the fields. Reported concentrations of bioaccessible arsenic are typically below 23 mg/kg in field areas, although exceptions have been identified in some areas. This action level can be easily exceeded in former pesticide storage and mixing areas. In general, bioaccessibility is higher in iron-poor, coralline sands in comparison to iron-rich volcanic soils.

Although not necessary from a health risk standpoint, owners of existing homes where pesticide-related, Category B soils are identified may want to consider measures to minimize exposure to arsenic in the soil as summarized in Table 1 and discussed in the HDOH fact sheet *Arsenic in Hawaiian Soils: Questions and Answers on Health Concerns* (HDOH 2010b; see also 2008c).

HDOH discourages the use of Category B soils with greater than 100 mg/kg *total* arsenic in the fines soil fraction (< 250µm) as fill material in offsite areas without further consultation, even if bioaccessible arsenic meets action levels for unrestricted use. This is intended to limit the movement of contaminated soil to otherwise un-impacted areas, as well as address a potential increase in bioaccessibility with the addition of phosphate fertilizers in lawns or gardens in new developments. Investigations carried out by HDOH in several heavily-impacted community garden soils on the Big Island (>400 mg/kg total

arsenic in the fines soil fraction; HDOH 2007) suggested an increase in bioaccessible arsenic (15-20%) in comparison to equally-contaminated soils in the surrounding areas (1-10%). A limit of total arsenic to 100 mg/kg in fines is intended to approximate the target Category B limit of 23 mg/kg under a worst-case, 25% bioaccessibility for arsenic in iron-rich, volcanic soils.

Category C Soils (moderately impacted): Bioaccessible arsenic between 23 mg/kg and 95 mg/kg; Commercial/Industrial Land Use Only. Category C soils are exemplified by contamination at former pesticide storage and mixing areas and wood treatment facilities. Category C soils have also been identified in community gardens associated with former sugarcane plantations (with elevated arsenic also identified in the adjacent field areas), at the site of a former Canec manufacturing site (see HDOH 2010c), and in some industrial areas believed to have been historically treated with arsenic herbicides for weed control.

Category D Soils (heavily impacted): Bioaccessible arsenic greater than 95 mg/kg; Remedial Actions Required. Category D soils have been identified at a small number of former pesticide mixing areas (e.g., sugarcane operations), former plantation housing areas and wood treatment facilities. Concentrations of total arsenic in soil typically exceed several thousand milligrams per kilogram. These soils are often co-located with heavy dioxin contamination (associated with use of pentachlorophenol) and in some cases triazine pesticides. Pentachlorophenol and triazine pesticides successively replaced the use of arsenic-base herbicides in the 1930s and 1970s, respectively (see HDOH 2010a; refer also to Section 9 in the HEER office Technical Guidance Manual, HDOH 2009).

A site-specific, Environmental Hazard Management Plan (EHMP) must be prepared for all sites where Category C and D soils are to be left in place for long-term management (HDOH 2008b, 2009). Information to be provided in the EHMP includes:

- To-scale maps that specify the location, thickness and depth of Category C and D soils;
- Summary of the specific environmental hazards potentially posed by the contaminated soil;
- Required institutional and engineering controls (e.g., restricted use, capping requirements, etc.);
- Fugitive dust and storm water runoff control measure;
- Measures for protection of workers involved in future construction or trenching projects that might disturb Category D soils.

Inappropriate reuse of Category C or D soils in offsite areas is of particular concern when excess soil is generated during construction or trenching projects. Clean fill should be used in utility corridors to minimize worker exposure and inadvertent reuse of removed soil in offsite areas. Refer to the HEER office *Environmental Hazard Evaluation* guidance (HDOH 2008b) and *Technical Guidance Manual* (HDOH 2009) for additional information. A copy of the EHMP should be retained by the property owner and lessees, as well submitted to HDOH for inclusion in the public record for the subject site.

3.0 Comparison of Soil Exposure to Dietary Exposure

The unrestricted (e.g., residential) soil action level of 23 mg/kg for bioaccessible, inorganic arsenic equates to a hypothetical, daily exposure dose for a 15kg child of approximately 4.0 micrograms (based on assumed soil ingestion rate, exposure duration and frequency, etc.; see HDOH 2008a). The commercial/industrial action level of 95 mg/kg equates to a daily exposure dose for a 70kg worker of 7.0 micrograms. Actual exposures to arsenic in soil for both children and adults are likely to be much lower due to the conservative nature of the exposure factors used in the calculations.

Exceeding the soil action level and the hypothetical exposure dose does not imply that an adverse health risk will occur, only that additional evaluation is warranted. This is because the Reference Dose (RfD) used to calculate the soil action level (i.e., 0.3 ug/kg-day; USEPA 2010a) incorporates an inherent uncertainty and margin of safety, due to the nature of toxicological risk assessment. As stated in IRIS summary for arsenic, “Risk managers should recognize the considerable flexibility afforded them in formulating regulatory decisions when uncertainty and lack of clear consensus (on toxicity factors) are taken into account.”

Arsenic is a naturally occurring element in the earth’s soil and water. As such it is naturally present in trace amounts in food. A comparison of exposure to inorganic arsenic in the diet to exposure from soil helps put the stated action levels into perspective, as shown in the table below (see Attachment 2 for detailed explanation):

Receptor	Exposure (ug/kg-day)	
	*Soil	Dietary
Child (15 kg)	4.0	18
Adult (70 kg)	7.0	44

*Exposure to Category B (Child) and C (Adult Worker) soil.

Based on a typical Pacific-Asian diet that is rich heavy in rice and fish, dietary inorganic arsenic exposures are estimate to be as high as 18 ug/day for children (1.2 ug/kg-day for a 15 kg child) and 44 ug/day for adults (0.6 ug/kg-day for a 70 kg adult). Rice accounts for the majority of dietary, inorganic arsenic (see Attachment 2).

Dietary exposure to inorganic arsenic is therefore anticipated to far exceed exposure to arsenic in soil at the stated action levels. The majority of exposure to inorganic arsenic in the diet comes from rice (see Attachment 2), which naturally accumulates arsenic and other elements in the soil when grown under wet conditions. Regular consumption of rice has not been shown to pose a significant health risk due to the presence of arsenic or other metals. Fish contains a significant amount of relatively non-toxic, *organic* arsenic (“fish arsenic”) but can also contribute to a small portion of total inorganic arsenic exposure.

4.0 Comparison to 2010 Draft USEPA Arsenic Toxicity Review

The USEPA published draft, proposed changes to the cancer slope factor for inorganic arsenic in February 2010 (USEPA 2010b). The draft USEPA document recommends an *increase* in current cancer slope factors for inorganic arsenic by more than an order of magnitude under some circumstances. In theory this could result in a *reduction* of cancer-based soil action levels by a similar magnitude. As stated in the draft USEPA document: “(This document) has not been formally disseminated by EPA. It does not represent and should not be construed to represent any Agency determination or policy.”

The draft USEPA (2010b) cancer slope factors for arsenic are based on doses that are orders of magnitude higher than are typically associated with exposures to soils (e.g., 100s to 1,000s ug/day vs <5 ug/day for exposures to Category B soils. There is considerable debate among both regulators and private entities regarding the applicability of both current and proposed cancer slope factors to very low doses of inorganic arsenic typically associated with exposure to soil as well as rice and other foods (e.g., USSBA 2010, EPRI 2010). As described in the 2008 technical memorandum, HDOH places a higher level of confidence in the noncancer toxicity factors and feels that the use of these factors in the development of soil action levels is more technically supportable for regulatory decisions (HDOH 2008a).

The use of conservative exposure assumptions in conjunction with a comparison to anticipated dietary exposure to inorganic arsenic provide additional lines of evidence to support the adequacy of the soil action levels to help separate low-risk sites from high risk sites and prioritize HDOH resources. HDOH considers the current approach to develop soil action levels as outlined in the 2008 technical memorandum to be appropriate for use in Hawai‘i and does not anticipate the need to adjust them in the foreseeable future.

References:

EPRI, 2010, (EPRI comments on) Draft Toxicological Review of Inorganic Arsenic: In Support of the Summary Information on the Integrated Risk Information System (IRIS) Docket ID No., EPA-HQ-ORD-2010-0123 (March 26, 2010): Electric Power Research Institute,
<http://mydocs.epri.com/docs/CorporateDocuments/Newsletters/ENV/QN-2010-05/01-01.html>

HDOH, 2007, Soil Arsenic Assessment Study Kea‘au, Hawai‘i (December 2007): Hawai‘i Department of Health, Hazard Evaluation and Emergency Response Office.

HDOH, 2008a, *Tier 2 Action Levels for Arsenic* (update to August 2006 memorandum, June 13, 2008): Hawai‘i Department of Health, Hazard Evaluation and Emergency Response Office.

- HDOH, 2008b, *Evaluation of Environmental Hazards at Sites with Contaminated Soil and Groundwater (Summer 2008, updated March 2009)*: Hawai'i Department of Health, Hazard Evaluation and Emergency Response Office, <http://www.hawaii.gov/health/environmental/hazard/eal2005.html>.
- HDOH, 2008c, *Homeowners Guide to Soil Testing for Arsenic*: Hawai'i Department of Health, Hazard Evaluation and Emergency Response Office, <http://www.hawaiidoh.org/>.
- HDOH, 2009, *Technical Guidance Manual* (and updates): Hawai'i Department of Health, Office of Hazard Evaluation and Emergency Response, <http://www.hawaiidoh.org/>.
- HDOH, 2010a, *Update to Soil Action Levels for TEQ Dioxins and Recommended Soil Management Practices* (June 2010): Hawai'i Department of Health, Hazard Evaluation and Emergency Response Office, <http://www.hawaii.gov/health/environmental/hazard/eal2005.html>.
- HDOH, 2010b, *Arsenic in Hawaiian Soils: Questions and Answers on Health Concerns*: Hawai'i Department of Health, Hazard Evaluation and Emergency Response Office, <http://www.hawaiidoh.org/>.
- HDOH, 2010c, *Arsenic in Canec Ceilings and Wallboard in Hawai'i*: Hawai'i Department of Health, Hazard Evaluation and Emergency Response Office, <http://www.hawaiidoh.org/>.
- UCR, 1996, *Kearney Foundation Special Report, Background Concentrations of Trace and Major Elements in California Soils* (March 1996): University of California (Riverside), Kearney Foundation of Soil Science, Division of Agriculture and Natural Resources. <http://www.envisci.ucr.edu/downloads/chang/kearney/kearneytext.html>
- USAF, 2005, *Base-wide Ambient Metals Study, Hickam Air Force Base, O'ahu, Hawai'i* (August 26, 2005): US Air Force, 15th Airlift Wing, Environmental Restoration Program.
- USEPA, 1998, *Inorganic Arsenic* (April 10, 1998): U.S. Environmental Protection Agency, Integrated Risk Information System, <http://www.epa.gov/ncea/iris/subst/0278.htm>
- USEPA, 2010a, *IRIS Toxicological Review of Inorganic Arsenic (Cancer) (External Review Draft)*: U.S. Environmental Protection Agency, Washington, DC, EPA/635/R-10/001, 2010, www.epa.gov/iris.
- USEPA, 2010b, *Integrated Risk Information System (IRIS)*, www.epa.gov/iris.
- USGS, 2001, *Geochemical Landscapes of the Conterminous United States-New Map Presentations for 22 Elements*: U.S. Geological Survey, Professional Paper 1648, <http://pubs.usgs.gov/pp/p1648/>

USN, 2006, Environmental Background Analysis of Metals in Soil at Navy O'ahu Facilities, O'ahu, Hawai'i (June 6, 2006): United States Department of the Navy, Naval Facilities Engineering Command, Hawai'i.

USSBA, 2010, Comments to the EPA Science Advisory Board (June 9, 2010): US Small Business Administration, Inorganic Arsenic Cancer Review Work Group, [http://yosemite.epa.gov/sab/sabproduct.nsf/CB8DB9B8B328A4A58525773E006298BB/\\$File/June+9+2010+Arsenic+SBA+Advocacy+SAB+Comments+.pdf](http://yosemite.epa.gov/sab/sabproduct.nsf/CB8DB9B8B328A4A58525773E006298BB/$File/June+9+2010+Arsenic+SBA+Advocacy+SAB+Comments+.pdf)

Table 1. Summary of Inorganic Arsenic Soil Action Levels and associated soil management categories.

Soil Management Category	Action
Total Arsenic (< 2 mm size fraction)	
<p>Category A Total Arsenic ≤20 mg/kg</p>	<p>Background. Within range of expected background conditions in non-agricultural and non-industrial areas. No further action required and no restrictions on land use.</p>
Bioaccessible Arsenic (<250 μm size fraction)	
<p>Category B Total Arsenic >20 mg/kg and Bioaccessible Arsenic ≤23 mg/kg</p>	<p>Minimally Impacted-Unrestricted Land Use. Exceeds expected background conditions but at levels anticipated for many agricultural fields where arsenic-based chemicals were used historically. Potential health risks considered to be within the range of acceptable health risks for long-term exposure. Include Category B soil in remedial actions for more heavily contaminated spill areas as practicable in order to reduce exposure (e.g., outer margins of pesticide mixing areas). Offsite reuse of soil for fill material not recommended for soil with >100 mg/kg total arsenic (see text). Use of soil for intermediate (e.g., temporarily inactive portions) or interim (e.g., daily or weekly) cover at a regulated landfill is acceptable, pending agreement by the landfill and barring hazardous waste restrictions.</p> <p>Although not strictly necessary from a health-risk standpoint, owners of existing homes where pesticide-related, Category B soils are identified may want to consider measures to reduce daily exposure to soil (e.g., maintain lawn cover, ensure good hygiene, thoroughly wash homegrown produce, etc) as described in the HDOH fact sheet <i>Arsenic in Hawaiian Soils: Questions and Answers on Health Concerns</i> (HDOH 2010c).</p> <p>For new developments on large, former field areas, notify future homeowners of elevated levels of arsenic on the property and recommend similar, precautionary measures (e.g., include in information provided to home buyers during property transactions, see also HDOH 2008b).</p>
<p>Category C (Bioaccessible Arsenic >23 but ≤95 mg/kg)</p>	<p>Moderately Impacted-Commercial/Industrial Land Use Only. Identified at several, former pesticide mixing areas and wood treatment facilities. May be co-located with pentachlorophenol, dioxin and triazine pesticide contamination at agricultural sites.</p> <p>Restriction to commercial/industrial land use is typically required in the absence of remediation or significant institutional and engineered controls and HDOH approval. Use of soil as soil as intermediate (e.g., temporarily inactive portions) or interim (e.g., daily or weekly) cover at a regulated landfill is acceptable, pending agreement by the landfill and barring hazardous waste restrictions.</p> <p>Preparation of a site-specific, <i>Environmental Hazard Management Plan</i> (EHMP) required if soil is left on site for long-term management (HDOH 2008b, 2009). Treatment to reduce bioavailability and/or removal of isolated spill areas is recommended when practicable in order to minimize future management and liability concerns. This includes controls to ensure no off-site dispersion (e.g., dust or surface runoff) or inadvertent excavation and reuse at</p>

	properties with sensitive land uses.
<p>Category D (Bioaccessible Arsenic >95 mg/kg)</p>	<p>Heavily Impacted-Remedial Actions Required. Identified at a small number of former pesticide storage and mixing areas (e.g., sugarcane operations), former plantation housing areas and wood treatment facilities. May be co-located with dioxin and triazine pesticide contamination.</p> <p>Remedial actions required under any land use scenario in order to reduce potential exposure. Potentially adverse health risks under both sensitive and commercial/industrial land use scenarios in the absence of significant institutional and/or engineered controls. Disposal of soil at a regulated landfill is acceptable, pending agreement by the landfill and barring hazardous waste restrictions. Preparation of site-specific EHMP required if left on site.</p>

ATTACHMENT 1

2008 HDOH ARSENIC ACTION LEVEL GUIDANCE

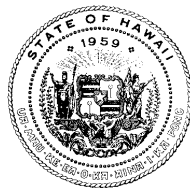

STATE OF HAWAII
DEPARTMENT OF HEALTH
P.O. Box 3378
HONOLULU, HAWAII 96801-3378

In reply, please refer to:
File: EHA/HEER Office

TO: Interested Parties

FROM: Roger Brewer
Environmental Risk Assessment
HEER Office

THROUGH: Barbara Brooks
Toxicologist
HEER Office

DATE: June 13, 2008

SUBJECT: Tier 2 Action Levels for Arsenic (update to August 2006 memorandum)

This technical memorandum presents Tier 2 action levels and corresponding guidance for arsenic-contaminated soils. The guidance serves as an addendum to the Hazard Evaluation and Emergency Response (HEER) office document *Evaluation of Environmental Hazards at Sites with Contaminated Soil and Groundwater* (HDOH 2008a). The guidance updates and takes precedence over guidance published in August 2006 (HDOH 2006). The update primarily addresses recommendations for the management of Category 2 soils in former agricultural fields. Similar guidance has been prepared for dioxin-contaminated soils (HDOH 2008b)

The guidance is especially intended for use during the redevelopment of former agricultural areas, although it is applicable to any site where releases of arsenic may have occurred. The action levels should be used to help determine the extent and magnitude of arsenic-contaminated soils and help guide the scope of remedial actions needed. The action levels are intended to serve as guidelines only, however, and do not represent strict, regulatory cleanup requirements. Alternative action levels may be proposed for any site in a site-specific, environmental risk assessment.

Overview

The action levels presented are based on concentrations of *bioaccessible* arsenic in soil. *Total* arsenic data are considered appropriate for comparison to anticipated background levels of arsenic in soil but not for use in human health risk assessment or for setting risk-based action levels. An action level of 4.2 mg/kg bioaccessible arsenic is recommended for residential sites. For commercial/industrial sites, an action level of 19 mg/kg bioaccessible arsenic is recommended. Remediation of sites to permit future, unrestricted, residential land use is encouraged when technically and economically feasible. "Residential" use includes both single-family homes and high-density developments, where open spaces essentially serve as residential "backyards." Schools, parks, playgrounds, and other open public spaces that adult and child residents may visit on a regular basis should also be initially assessed under a residential use exposure scenario. Short- and long-term remedial actions in the latter areas may differ from

actions recommended for high-density and single-family residential properties, however, due to greater control over digging and other activities that may expose contaminated soil.

Additional guidance and action levels are provided for sites where the preferred action levels noted above cannot be reasonably met and continued use or redevelopment of the site is still desired. Three categories of arsenic-contaminated soil are defined for both residential and commercial/industrial sites. Residential, Category 1 soils (R-1) are not considered to pose a significant risk to human health under any potential site conditions and can be reused onsite or offsite as desired. Commercial/Industrial, Category 1 soils (C-1) can be used as needed on commercial/industrial sites but should not be used as fill material offsite without prior consultation with HDOH.

Category 2 Residential (R-2) and Commercial/Industrial (C-2) soils are not considered to pose a significant risk to human health under the specified land use. As a best management practice, however, HDOH recommends the removal or capping of Category 2 soils associated with easily identifiable, localized spill areas when feasible (e.g., past pesticide mixing or storage). HDOH does not consider capping or removal of Category 2 soils in large, former field areas to be necessary or practicable.

Category 3 Residential (R-3) and Commercial/Industrial (C-3) soils are considered to pose an unacceptable risk to human health and should be removed from the site or isolated onsite under permanent structures or properly designed caps, as described below.

Remediation of residential and commercial/industrial properties to action levels for Category 2 soils is recommended to the extent technically and economically feasible, however, and should be discussed with the HEER office on a site-by-site basis. Reuse of Category 2 Commercial/Industrial soil for daily cover at a regulated landfill may be acceptable but should be discussed with the landfill operator as well as the HDOH Solid and Hazardous Waste Branch.

Background

Significantly elevated levels of arsenic have been identified in soils from former sugar cane fields and pesticide mixing areas in Hawai'i, as well as in and around former plantation camps. High levels of arsenic have also been identified in soil samples from at least one former golf course. The presence of the arsenic is believed to be related the use of sodium arsenite and other arsenic-based pesticides in and around the cane fields in the 1920s through 1940s. During this period, up to 200,000 acres of land in Hawai'i was being cultivated for sugar cane. The arsenic is generally restricted to the upper two feet of the soil column (approximate depth of plowing). Alternative action levels and approaches may be acceptable for contaminated soils situated greater than three feet below ground surface and should be discussed with HDOH on a site-by-site basis.

Current studies have focused on the Kea'au area of the Big Island. Soils in the area have been described as stony, organic, iron-rich Andisols (Cutler et al., 2006). Concentrations of total arsenic in soils from undeveloped former sugar cane lands in this area have been reported to range from 100-400 mg/kg in the ≤ 2 mm size fraction of the soil and >500 mg/kg in the $<250\mu\text{m}$ size fraction (report pending). Concentrations greater than 1,000 mg/kg have been reported in one former plantation camp area. Background concentrations of arsenic in native soils range from 1.0 mg/kg up to 20 mg/kg. The presence of the arsenic initially posed concerns regarding potential groundwater impacts, uptake in homegrown produce and direct exposure of residents and workers to contaminated soil. Maximum-reported concentrations of bioaccessible arsenic in

soil are far below levels that would cause immediate, acute health affects. Continued exposure to arsenic in heavily contaminated soils over many years or decades could pose long-term, chronic health concerns, however.

Arsenic has not been detected in municipal groundwater wells in the area. Testing of produce from gardens in the Kea‘au area by the Department of Health in 2005 also did not identify levels of arsenic above U.S. norms, even though total arsenic in the garden soils approached or exceeded 300 mg/kg in the ≤ 2 mm size fraction. Uptake of the arsenic in edible produce or other plants therefore does not appear to be a significant environmental health concern. These observations suggest that the arsenic is tightly bound to the soil and not significantly mobile. This is further supported by petrologic and leaching studies as well as “bioaccessibility” tests conducted on the soils (Cutler et al., 2006). Despite being relatively immobile, however, elevated levels of arsenic in some areas could still pose a potential chronic health risk to residents and workers who come into regular contact with the soil. The action levels and soil categories discussed below are intended to address this concern.

The evaluation of soil for arsenic has traditionally focused on the *total* amount of arsenic present and comparison to action levels based on a target excess cancer risk of one-in-a-million or 10^{-6} . This has always presented a dilemma in human health risk assessments. Natural, background concentrations of arsenic in soils are typically much higher than risk-based action levels for total arsenic. For example, the residential soil action level for arsenic presented in the HDOH document *Screening For Environmental Concerns at Sites With Contaminated Soil and Groundwater* is 0.42 mg/kg (HDOH 2008a, Appendix 1, Table I-1), while background concentrations of arsenic in soil in Hawai‘i may range up to 20 mg/kg or higher. In addition, much of the arsenic in pesticide-contaminated soil appears to be tightly bound to soil particles and not *available* for uptake in the human body. This portion of the arsenic is essentially nontoxic. These two factors led to a need for further guidance, particularly with respect to the use of *bioaccessible* arsenic data in human health risk assessments and in the development of risk-based, soil action levels.

Bioavailable and Bioaccessible Arsenic

Risk to human health posed by exposure to a contaminant in soil is evaluated in terms of the average daily dose or *intake* of the contaminant for an exposed person (e.g., in milligrams or micrograms per day; USEPA 1989, 2004). Intake can occur through incidental ingestion of soils, inhalation of dust or vapors, and to a lesser extent (for most contaminants) absorption through the skin. Assumptions are made about the fraction of the contaminant that is available for *uptake* in a persons blood stream via the stomach and small intestine. This is referred to as the *bioavailability* of the contaminant (NEPI 2000). The most widely accepted method to determine the bioavailability of a contaminant in soil is through *in vivo* studies where the soil is incorporated into a lab test animal’s diet. In the case of arsenic, the amount that is excreted in the animal’s urine is assumed to represent the fraction that entered the animal’s blood stream and was available for uptake.

In vivo bioavailability tests are time consuming and expensive, however, and not practical for routine site evaluations. As an alternative, faster and more cost-effective laboratory tests have been developed to estimate arsenic bioavailability in soil. These methods, referred to as *in vitro* bioaccessibility tests, utilize an acidic solution intended to mimic a child’s digestive tract (typically a glycine-buffered hydrochloric acid solution at pH 1.5; Ruby 1999; Gron and Andersen, 2003). Soil with a known concentration and mass of arsenic is placed in the solution and allowed to equilibrate for one hour. An extract of the solution is then collected and analyzed

for arsenic. The concentration of arsenic in the solution is used to calculate the total mass of arsenic that was stripped from the soil particles. The ratio of the arsenic mass that went into solution to the original mass of arsenic in the soil is referred to as the *bioaccessible* fraction of arsenic.

The results of *in vitro* bioaccessibility tests for arsenic compare favorably with *in vivo* bioavailability studies (Ruby 1999; Gron and Andersen, 2003). This is supported by studies of arsenic-contaminated soils from the Kea'au area of the Big Island of Hawai'i. Samples of the soil were tested for bioavailable arsenic in an *in vivo* monkey study carried out by the University of Florida in 2005 and simultaneously tested for bioaccessible arsenic by *in vitro* methods (report pending publication). The concentration of total arsenic in the samples was approximately 700 mg/kg. The study concluded that the bioavailability of arsenic in the soil ranged from 3.2% to 8.9%. This correlated well with an *in vitro* test carried out on the same soil that yielded an arsenic bioaccessibility of 6.5%. The bioaccessibility of arsenic in soils from the same site was estimated to range from 16% to 20% in a separate study, suggesting that the *in vitro* test method may err on the conservative side in comparison to the more standard *in vivo* method (Cutler et al., 2006). This has been observed in other studies of bioavailability versus bioaccessibility. Bioaccessibility tests on soils from other areas around Kea'au yielded similar results and again indicated that 80% to >90% of the arsenic in the soil is so tightly bound to soil particles that it is essentially "nontoxic."

Bioaccessible arsenic was observed to increase with increasing total arsenic concentration (Cutler et al., 2006). This is probably because much of the arsenic in heavily contaminated soils is fixed to low-energy binding sites on soil particles and comparatively easy to remove. Continued stripping of remaining arsenic from progressively higher-energy binding sites requires greater effort (i.e., the arsenic becomes progressively less bioaccessible). Data from the study also indicate that arsenic bioaccessibility (and therefore toxicity) may increase with increasing phosphorous concentration in soil related to the use of fertilizers in gardens. This is because phosphorus is able to out compete arsenic for high-energy binding sites on soil particles. The relationship has not been fully demonstrated, however, and is still under investigation.

Based on a review of published literature and studies conducted to date in Hawai'i, HDOH considers arsenic bioaccessibility tests to be sufficiently conservative and an important tool in the assessment of arsenic-contaminated properties. Bioaccessible arsenic analyses should always be conducted on the $\leq 250\mu\text{m}$ size fraction of the soil since this is the fraction that is most likely to be incidentally ingested. Most soils only contain a small percentage of particles $250\mu\text{m}$ in size or less. This typically requires the collection of very large samples (several kilograms) to obtain the mass needed for bioaccessibility tests. Appropriate sample handling, processing, and sub-sampling by the lab conducting bioaccessibility testing is essential. Guidance on suggested procedures and quality control for bioaccessibility lab tests will be forthcoming from HDOH. For more information on this subject contact John Peard of the HDOH HEER office (john.peard@doh.hawaii.gov).

Basis of Soil Action Levels

Arsenic action levels and correlative soil categories for residential and commercial/industrial properties are presented in Tables 1 and 2 and summarized in Figure 1. An action level of 20 mg/kg total arsenic in the $\leq 2\text{mm}$ size soil fraction is recommended to screen out sites where naturally occurring ("background") concentrations of arsenic are not significantly exceeded (HDOH 2008a). Background total arsenic may approach 50 mg/kg in some areas but this is

considered rare. Analysis of soil samples for bioaccessible arsenic is recommended at sites where total arsenic exceeds anticipated background concentrations.

Action levels for bioaccessible arsenic are presented in Table 1 (residential land use) and Table 2 (commercial/industrial land use). The action levels are based on direct-exposure models used by USEPA to develop soil *Regional Screening Levels* (RSLs) (replace 2004 Preliminary Remediation Goals; USEPA 2008). The USEPA RSLs for arsenic for residential and commercial/industrial land use are 0.39 mg/kg and 1.6 mg/kg, respectively, based on a target excess cancer risk of 1×10^{-6} (one-in-a-million). Risk-based action levels for arsenic of 0.42 mg/kg and 1.9 mg/kg are presented in the HDOH document *Evaluation of Environmental Hazards at Sites with Contaminated Soil and Groundwater*, based on a similar target risk but assuming a slightly lower, dermal absorption factor (HDOH 2008a). Both the USEPA RSLs and the HDOH Tier 1 action levels assume that 100% of the soil arsenic is bioavailable.

The USEPA RSLs and HDOH Tier 1 action levels for total arsenic are far below typical background concentrations of arsenic in soils from Hawai'i, as well as most of the mainland US. To address this issue, action levels for Category 1 soils in Tables 1 and 2 are based on a target excess cancer risk of 1×10^{-5} (one-in-one-hundred-thousand) rather than 1×10^{-6} . This generates residential and commercial/industrial action levels for bioaccessible arsenic of 4.2 mg/kg and 19 mg/kg, respectively. These action levels serve as useful starting points to help identify arsenic-contaminated sites that warrant further evaluation.

A second set of action levels is used to define soils that are most likely impacted above natural background levels but still may be acceptable for use in residential or commercial/industrial areas if adequate lawns and landscaping are maintained (Category 2 soils). An action level of 23 mg/kg bioaccessible arsenic was selected as an upper limit for soils in residential areas (Table 1). This reflects a noncancer Hazard Quotient of 1.0 and correlates to an excess cancer risk of approximately 5×10^{-5} . Commercial/industrial action levels based on a similar excess cancer risk of 5×10^{-5} and a noncancer Hazard Quotient of 1.0 are 95 mg/kg and 310 mg/kg, respectively. Since the correlative action level for excess cancer risk is less than the action level for noncancer risk, the former (95 mg/kg) was chosen as an upper limit for soils in commercial/industrial areas (Table 2). These action levels are used to define the lower boundary of Category 3 soils.

At concentrations greater than 180 mg/kg, bioaccessible arsenic in soil begins to pose a potentially significant health risk to construction workers and utility workers (HDOH 2008a, refer to Table I-3 in Appendix 1, based on an excess cancer risk of 1×10^{-5}). As discussed below, this is used as a "ceiling level" for soil that can be isolated under clean soil caps, buildings or paved areas.

The action levels for bioaccessible arsenic were used to group soils into three categories (see Tables 1 and 2). A discussion of potential remedial actions at each site that fall into these soil categories is provided in the following sections. The ultimate action taken at an individual site will be dependent on numerous site-specific factors, including current and planned land use, available options for onsite isolation or offsite disposal, and technical and economic constraints.

Soil Categories and Action Levels for use at Residential Sites

Category 1 Soils (R-1): Bioaccessible Arsenic ≤ 4.2 mg/kg, No Further Action

Long-term exposure to Category 1 (R-1) residential soils is not considered to pose a significant risk to residents. No further action is necessary at sites where the reported concentration of bioaccessible arsenic in soil is equal to or below 4.2 mg/kg.

Utility corridors should be backfilled with clean fill material (e.g., R-1 soils) or at a minimum R-2 soils in order to prevent excavation of contaminated soil and inappropriate reuse in other areas in the future. R-3 soils should not be placed in utility corridors.

Category 2 Soils (R-2): Bioaccessible Arsenic >4.2 mg/kg and ≤23 mg/kg, Consider Removal or Isolation of Localized Spill Areas

Long-term exposure to Category 2 (R-2) residential soils is not considered to pose a significant risk to residents. As a best management practice, however, HDOH recommends the removal or capping of Category 2 soils associated with easily identifiable, localized spill areas when feasible (e.g., past pesticide mixing or storage). HDOH does not consider capping or removal of Category 2 soils in large, former field areas to be necessary or practicable. These issues are discussed in more detail below.

At sites where R-2 soils are discovered in the vicinity of existing homes, residents should be encouraged to minimize exposure to the soil by taking the following precautions:

- Reduce areas of bare soil by planting and maintaining grass or other vegetative cover, or cover barren areas with gravel or pavement.
- Keep children from playing in bare dirt.
- Keep toys, pacifiers, and other items that go into childrens' mouths clean.
- Wash hands and face thoroughly after working or playing in the soil, especially before meals and snacks.
- Wash fruits and vegetables from home gardens before bringing them in the house. Wash again with a brush before eating or cooking to remove any remaining soil particles. Pare root and tuber vegetables before eating or cooking.
- Bring in clean sand for sandboxes and bring in clean soil for garden areas or raised beds.
- Avoid tracking soil into the house and keep the floors of the house clean. Remove work and play shoes before entering the house.

Testing of produce from gardens in the Kea'au area by the Department of Health in 2005 did not identify levels of arsenic above U.S. norms. Uptake of the arsenic in edible produce or other plants does not appear to be a significant environmental health concern in former sugar cane operation areas. Produce should be thoroughly cleaned before cooking or eating, however, in order to avoid accidental ingestion of small amounts of soil.

Category 3 Soils (R-3): Bioaccessible Arsenic >23 mg/kg, Removal or Isolation Recommended

Long-term exposure of residents to Category 3 (R-3) residential soils is considered to pose potentially significant health risks. As discussed above, maximum-reported concentrations of bioaccessible arsenic in soil from former agricultural areas are far below levels that would cause immediate, acute health affects. Continued exposure to arsenic in R-3 soils over many years or decades could pose long-term, chronic health concerns, however.

Offsite disposal of R-3 soils in a permitted landfill facility is recommended when technically and economically feasible. Reuse of some or all of the soil as daily cover at a landfill may also be possible. This should be discussed with the landfill in question as well as with the HDOH Solid and Hazardous Waste Branch. Offsite disposal of soil with bioaccessible arsenic in excess of 180 mg/kg is especially recommended (action level for construction/trench work exposure).

Soils that fall into this category but cannot be disposed offsite due to technical and/or cost constraints should be placed in *soil isolation areas*. Optimally, a soil isolation area would be created under public buildings, private roadways, parking lots and other facilities/structures that constitute a permanent physical barrier that residents are unlikely to disturb in the future. Isolation of R-3 soils under public roadways should be done in coordination with the local transportation authority. Isolation of R-3 soils under permanent structures is preferable to isolation in open areas, due to the increased potential for open areas to be inadvertently disturbed during future gardening, landscaping or subsurface utility work. Soil that cannot be placed under a permanent structure or disposed of offsite should be isolated in well-controlled common areas, rather than on individual residential lots. Contaminated soil should be consolidated in as few isolation areas as possible. Areas where R-3 soils are placed and capped for permanent onsite management must be clearly identified on surveyed, post-redevelopment map(s) of the property. These maps should be included a risk management plan that is provided to HDOH for inclusion in the public file for the site (see “Identification of Soil Isolation Areas” below). Utility corridors should be backfilled with clean fill material (e.g., R-1 soils) when initially installed or following maintenance work in order to prevent excavation and inappropriate reuse of contaminated soil in the future.

Depending on site-specific conditions, permanent covers or caps for soil isolation areas may be constructed of paving materials such as asphalt and concrete (“hard cap”) or earthen fill material (“soil cap”) that meets R-1 (preferred) or R-2 action levels. A soil cap thickness of 24 inches is recommended for areas where landscaping activities may involve digging deeper than one foot or where gardens may be planted in the future (based on USEPA guidance for lead-contaminated soils, USEPA 2003). A cap of twelve inches may be acceptable in high-density residential redevelopments where gardens will not be allowed and use of the area will be strictly controlled. A clearly identifiable, marker barrier that cannot be easily penetrated with shovels or other handheld digging tools (e.g., orange construction fencing or geotextile webbing) should be placed between the contaminated soil and the overlying clean fill material. A similar marker barrier should be placed below or above gravel, concrete or other hard material placed on top of contaminated soil in order to avoid confusion with former building foundations or road beds.

Permeable marker barriers may be necessary in areas of high rainfall in order to prevent ponding of water during wet seasons. Leaching tests should be carried out on R-3 soils in order to evaluate potential impacts to groundwater (see discussion below).

When R-3 soils are identified at existing homes, removal or permanent capping of the soils should be strongly considered. In the interim, residents should follow the measures outlined for residential R-2 soils to minimize their daily exposure. Children should avoid areas of bare soil and regular work in garden areas.

Soil Categories and Action Levels for use at Commercial/Industrial Sites

Category 1 Soils (C-1): Bioaccessible Arsenic >4.2 mg/kg and ≤19 mg/kg, No Further Action

Long-term exposure to Category 1 (C-1) soils is not considered to pose a significant health risk to workers at commercial or industrial sites. Remediation of soil that exceeds action levels for residential, R-1 (preferred) or R-2 action levels, however, will minimize restrictions on future land use and should be considered when feasible. Note that this may require a more detailed sampling strategy than is typically needed for commercial/industrial properties (e.g., decision units 5,000 ft² in size or less). Long-term institutional controls to restrict use of property to commercial/industrial purposes may be required if the site will not be investigated to the level of detail required for future, unrestricted land use to ensure that action levels for Category 2 Residential soils are not exceeded

Category 2 Soils (C-2): Bioaccessible Arsenic >19 mg/kg and ≤95 mg/kg, Consider Removal or Isolation

Long-term exposure to Category 2 (C-2) soils is not considered to pose a significant risk to workers provided that lawns and landscaping are maintained to minimize exposure and control fugitive dust or if the soils. Remediation of commercial/industrial properties to action levels approaching those for C-1 soils or lower is recommended when technically and economically feasible, however, and should be discussed with the HEER office on a site-by-site basis. When selecting remedial options, long-term effectiveness should be given increasing weight as concentrations of bioaccessible arsenic approach the upper boundary for C-2 soils.

For new developments, isolation of C-2 soils under buildings, private roadways and other areas with a permanent cap that workers are unlikely to disturb in the future is recommended when feasible. Isolation of C-2 soils under public roadways should be done in coordination with the local transportation authority. Offsite reuse of C-2 soil as fill material should be avoided. Reuse of some or all of the soil as daily cover in a regulated landfill may be feasible, however. This should be discussed with the landfill in question as well as with the HDOH Solid and Hazardous Waste Branch. Areas of the property where capped or uncapped C-2 soil is located must be clearly identified on surveyed, post-redevelopment map(s) of the property and included in a risk management plan that is documented in the HDOH public file for the site (see “Identification of Soil Isolation Areas” below). Care must be taken to ensure that soil from these areas is not excavated and inadvertently reused in offsite areas where residents could be exposed on a regular basis. Utility corridors should be backfilled with clean fill material (e.g., R-1 soils) when initially installed or following maintenance work in order to prevent excavation and inappropriate reuse of contaminated soil in the future.

At existing facilities, areas of bare C-2 soils should be minimized by maintaining grass or other vegetative cover or by covering bare areas with gravel or pavement. Workers should be encouraged to maintain clean work areas and thoroughly wash hands before breaks and meals.

Category 3 Soils (C-3): Bioaccessible Arsenic >95 mg/kg, Removal or Isolation Recommended

Long-term exposure to Category 3 (C-3) soils is considered to pose potentially significant health risks to workers at commercial or industrial sites. Offsite disposal of C-3 soils is recommended when technically and economically feasible. Offsite disposal of soil with bioaccessible arsenic in excess of 180 mg/kg is especially recommended (action level for construction/trench work exposure). Soil that cannot be removed from the site should be placed in designated isolation areas under public buildings, private roadways, parking lots and other facilities/structures that constitute a permanent physical barrier that residents are unlikely to disturb in the future. Contaminated soil should be consolidated in as few isolation areas as possible. Areas of the property where C-3 soil is located must be clearly identified on surveyed, post-redevelopment map(s) of the property and included in a risk management plan that is documented in the HDOH public file for the site (see “Identification of Soil Isolation Areas” below). Care must be taken to ensure that soil from these areas is not excavated and inadvertently reused in offsite areas where residents could be exposed on a regular basis. Utility corridors should be backfilled with clean fill material (e.g., R-1 soils) in order to prevent inadvertent excavation and reuse of contaminated soil in other areas in the future.

As discussed for residential sites, isolation of contaminated soil under buildings or other permanent structures is preferred over isolation in open areas. If placement of the soil in an open area is necessary, use of areas that are unlikely to be disturbed in the future is preferred. A

minimum cap thickness of twelve inches is generally acceptable for commercial/industrial sites where use of the area will be strictly controlled (USEPA 2003). A clearly identifiable marker barrier should be placed between the contaminated soil and the overlying clean fill material (e.g., orange construction fencing or geotextile webbing). Fencing, geotextile fabric or similar, easily identifiable markers should likewise be placed above any gravel, concrete or other hard material placed on top of contaminated soil in order to avoid confusion with former building foundations or road beds.

Use of Total Arsenic Data

Based on data collected to date, it is possible that a significant portion of former sugar cane land situated in areas of high rainfall (e.g., >100 inches per year) will fall into the R-2 or C-2 soil categories as described above and summarized in Tables 1 and 2. Some of these areas have already been redeveloped for residential houses. Determination of bioaccessible arsenic levels on individual lots with existing homes may not be economically feasible for some residents (current analytical costs \$500 to \$1000). If site-specific, bioaccessible arsenic data is not affordable for a private homeowner, HDOH recommends that the soil be tested for total arsenic (generally less than \$100). The resulting data should then be adjusted using a default *bioavailability* value to estimate bioavailable arsenic concentrations. Based on data collected to date in the Kea'au area, a 10% bioavailability factor (BF) is recommended for total arsenic values at or below 250 mg/kg. Measured concentrations of total arsenic should be multiplied by 0.1 and the adjusted concentration compared to the action levels in Table 1 or Table 2. For total arsenic above 250 mg/kg, a more conservative bioavailability factor of 20% (0.2) is recommended.

For residential sites, this approach corresponds to an upper limit of 42 mg/kg total arsenic for R-1 soils and 230 mg/kg total arsenic for R-2 soils (10% BF used). For commercial/industrial sites, this corresponds to an upper limit of 190 mg/kg total arsenic for C-1 soils (10% BF used) and 475 mg/kg total arsenic for C-2 soils (20% BF used). Soils that potentially fall into Category 3 for residential or commercial/industrial sites should be tested for bioaccessible arsenic if at all possible. In the absence of bioaccessibility data, it is recommended that children avoid playing or working in gardens or other areas where total arsenic action levels indicate the potential presence of R-3 soils. The default bioaccessibility factors presented were developed based on data from the Kea'au region and are subject to revision as more data becomes available.

The total arsenic action levels proposed above should not be used for general screening purposes at sites where a formal environmental investigation is being carried out. As previously discussed and as noted in the summary tables, bioaccessible arsenic data should be collected at all sites where total arsenic concentrations exceed an assumed background concentration of 20 mg/kg unless otherwise approved by HDOH.

Soil Sampling Methods

The use of multi-increment field soil sampling and lab sub-sampling techniques is recommended over the use of discrete or traditional composite sampling techniques. This sampling approach allows for the determination of a statistically representative concentration of arsenic within a specific area of investigation or "decision unit," such as an individual yard, a park, a garden or a well-defined spill area. Additional guidance on the use of multi-increment and decision unit investigation strategies will be provided in the 2008 update to the HEER office *Technical Guidance Manual*.

Other Potential Environmental Concerns

A discussion of environmental hazards associated with contaminated soil is provided in the HDOH document *Evaluation of Environmental Hazards at Sites with Contaminated Soil and Groundwater* (HDOH 2008a). The arsenic action levels presented in this technical memorandum address human-health, direct-exposure hazards only. The action levels do not address potential leaching of arsenic from soil and subsequent impacts to underlying groundwater or potential toxicity to terrestrial flora and fauna. These issues should be evaluated on a site-specific basis as directed by HDOH. Arsenic is not considered to pose significant vapor intrusion or gross contamination hazards.

Based on data collected to date, leaching of arsenic from former sugar cane fields is not anticipated to pose a significant concern in Hawai'i due to the apparent, relative immobility of the arsenic. Additional field data are needed to support this assumption, however, particularly for soils that exceed the upper action level for R-2 residential soils (i.e., >23 mg/kg bioaccessible arsenic). HDOH recommends that potential leaching of arsenic from soils that exceed 23 mg/kg bioaccessible arsenic be evaluated using the USEPA Synthetic Precipitation Leaching Procedure (SPLP) test or a comparable method. Refer to the HDOH technical memorandum *Use of Laboratory Batch Tests to Evaluate Potential Leaching of Contaminants from Soil* for additional guidance (HDOH 2007).

Assessment of additional pesticides and pesticide-related contaminants in agricultural areas should be carried out as needed based on the past use of the property. Refer to the 2008 update of the HEER office *Technical Guidance Manual* for additional information on target pesticides.

Environmental Hazard Evaluation Plans

Isolation areas where arsenic-contaminated soil is to be capped for permanent onsite management must be clearly identified on surveyed, post-redevelopment map(s) of the property. Areas of soil at commercial/industrial sites that exceed action levels for residential R-1, R-2 and R-3 soils should also be clearly surveyed and mapped. The maps identifying arsenic-impacted soils should be incorporated into an *Environmental Hazard Evaluation Plan* (EHMP, HDOH 2008a) that describes proper management, reuse and disposal of contaminated soil if disturbed during later redevelopment activities. A copy of the plan should be submitted to both HDOH and to the agency(s) that grants permits for construction, trenching, grading or any other activities that could involve future disturbance or excavation of the soil. The need to incorporate the risk management plan and specific land use restrictions in a formal covenant to the property deed should be discussed with HDOH on a site-by-site basis. Additional guidance on EHMPs will be provided in the 2008 update to the HEER office *Technical Guidance Manual*.

References:

- Cutler, W.G., N. Hue, M.E. Ortiz-Escobar, and T. Martin, 2006, *Approaches to Reduce Bioaccessible Arsenic in Hawai'i Soils*: In Proceedings of Fifth Int'l Conference on Remediation of Chlorinated and Recalcitrant Compounds (Battelle Press), Monterey, CA. May 2006.
- Gron, C. and Andersen, L, 2003, *Human Bioaccessibility of Heavy Metals and PAH from Soil*: Danish Ministry of the Environment, Environmental Project No. 840 2003 Technology Programme for Soil and Groundwater Contamination, <http://www.mst.dk/homepage/> (search under Publications Database - Technical Reports).
- HDOH, 2006, *Soil Action Levels and Categories for Bioaccessible Arsenic* (August 2006): Hawai'i Department of Health, Office of Hazard Evaluation and Emergency Response, <http://www.hawaii.gov/health/environmental/hazard/eal2005.html>
- HDOH, 2007a, *Use of laboratory batch tests to evaluate potential leaching of contaminants from soil* (April 2007): Hawai'i Department of Health, Office of Hazard Evaluation and Emergency Response, <http://hawaii.gov/health/environmental/hazard/environmental/hazard/index.html>
- HDOH, 2008a, *Evaluation of Environmental hazards at Sites with Contaminated Soil and Groundwater* (Summer 2008, in preparation): Hawai'i Department of Health, Hazard Evaluation and Emergency Response Office, <http://hawaii.gov/health/environmental/hazard/environmental/hazard/index.html>.
- HDOH, 2008b, *Tier 2 Soil Action Levels and Categories for TEQ Dioxins* (June 2008): Hawai'i Department of Health, Office of Hazard Evaluation and Emergency Response.
- NEPI, 2000, *Assessing the Bioavailability of Metals in Soil for Use in Human Health Risk Assessments*. Bioavailability Policy Report Phase II: Metals Task Force Report. National Environmental Policy Institute (NEPI). Summer 2000.
- Ruby, M.V., et al., 1999, *Advances in evaluating the oral bioavailability of inorganics in soil for use in human health risk assessment*. *Environmental Science Technology* 33:3697-3705.
- USEPA, 1989, *Risk Assessment Guidance for Superfund. Volume I, Human Health Evaluation Manual (Part A)*: U.S. Environmental Protection Agency, Office of Emergency and Remedial Response, Publication EPA/540/1-89/092.
- USEPA, 1999, *Understanding Variation in Partition Coefficient, Kd, Values*: Office of Air and Radiation, August 1999, EPA/402/R/99/004A, <http://www.epa.gov/radiation/docs/kdreport/>
- USEPA, 2003, *Superfund Lead-Contaminated Residential Sites Handbook* (August 2003): U.S. Environmental Protection Agency, Office of Emergency and Remedial Response, OSWER 9285.7-50, <http://www.epa.gov/superfund/lead/products/handbook.pdf>
- USEPA, 2004, *Preliminary Remediation Goals*: U.S. Environmental Protection Agency, Region IX, October 2004, www.epa.gov/region09/waste/sfund/prg/index.htm

USEPA, 2008, *Screening Levels for Chemical Contaminants*: U.S. Environmental Protection Agency, May 29, 2008, prepared by Oak Ridge National Laboratories, <http://epa-prgs.ornl.gov/chemicals/index.shtml>

Table 1. Soil categories and recommended actions for Residential Sites.

Total Arsenic (≤ 2 mm size fraction)	Action
≤ 20 mg/kg	Within range of natural background. No further action required and no restrictions on land use.
> 20 mg/kg	Exceeds typical background. Re-evaluate local background data as available. Test soil for bioaccessible arsenic if background is potentially exceeded.
Bioaccessible Arsenic ($\leq 250\mu\text{m}$ size fraction)	Action
R-1 Soils (≤ 4.2 mg/kg)	No further action required and no restrictions on land use.
R-2 Soils (> 4.2 but ≤ 23 mg/kg)	<p>Within USEPA range of acceptable health risk. Consider removal and offsite disposal of small, easily identifiable “hot spots” when possible in order to reduce potential exposure (not required for large, former field areas). Use of soil as daily cover at a regulated landfill may also be possible.</p> <p>For existing homes, consider measures to reduce daily exposure to soil (e.g., maintain lawn cover, ensure good hygiene, thoroughly wash homegrown produce, etc.). For new developments on large, former field areas, notify future homeowners of elevated levels of arsenic on the property (e.g., include in information provided to potential buyers during property transactions).</p>
R-3 Soils (> 23 mg/kg)	<p>For existing homes, removal or onsite isolation of exposed soil is strongly recommended. Consider a minimum one-foot cover of clean fill material (two feet in potential garden areas) if soil cannot be removed. An easily identifiable marker barrier should be placed between the contaminated soil and the overlying fill (e.g., orange construction fencing or geotextile/geonet material). In the interim, take measures to reduce daily exposure to soil (e.g., maintain lawn cover, ensure good hygiene, thoroughly wash homegrown produce, etc.). Children should avoid areas of bare soil and regular work in gardens areas.</p> <p>For new residential developments, removal and offsite disposal of soil should be strongly considered. At a minimum, consider removal and offsite disposal of soil with concentrations of bioaccessible arsenic that approach or exceed 180 mg/kg (direct exposure action level for construction and trench workers). Use of soil as daily cover at a regulated landfill may be possible if concentrations of bioaccessible arsenic meet C-2 commercial/industrial soil criteria.</p> <p>If offsite disposal is not feasible but redevelopment of the property is still desired, consider use of soil as structural fill under public buildings, parking lots, private roads, or other paved and well-controlled structures. If capping in open areas is unavoidable, consider a one-foot minimum cap thickness with an easily definable marker barrier placed between the soil and the overlying clean fill (e.g., orange construction fencing or geotextile fabric). Capping of R-3 soils on newly developed, private lots is not recommended due to difficulties in ensuring long-term management of the soil. Backfill utility corridors with clean fill material (e.g., R-1 soils) to avoid excavation and inappropriate reuse of the soil in the future.</p>

Table 1. Soil categories and recommended actions for Residential Sites (cont.).

R-3 Soils (cont.) (>23 mg/kg)	Require formal, long-term institutional controls to ensure appropriate management of soil in the future (e.g., Covenants, Conditions and Restrictions (CC&Rs), deed covenants, risk management plans, etc.). All areas of capped soil should be delineated on a surveyed map of the property to be subsequently included in the risk management plan.
---	---

The soil categories and arsenic action levels noted above are intended to be used as guidelines only and do not represent strict, regulatory cleanup requirements.

Table 2. Soil categories and recommended actions for Commercial/Industrial Sites.

Total Arsenic (≤ 2 mm size fraction)	Action
≤ 20 mg/kg	Within range of natural background. No further action required and no restrictions on land use.
> 20 mg/kg	Exceeds typical background. Re-evaluate local background data as available. Test soil for bioaccessible arsenic if background is potentially exceeded.
Bioaccessible Arsenic ($\leq 250\mu\text{m}$ size fraction)	Action
C-1 Soils (> 4.2 mg/kg but ≤ 19 mg/kg)	<p>No remedial action required. However, consider remediation of commercial/industrial properties to meet Residential R-1 (preferred) or R-2 action levels when feasible in order to minimize restrictions on future land use. Note that this may require a more detailed sampling strategy than typically needed for commercial/industrial properties (e.g., smaller decision units).</p> <p>Require formal, long-term institutional controls to restrict use of property to commercial/industrial purposes if the site will not be investigated to the level of detail required for future, unrestricted land use (i.e., inform potential buyers, deed covenants, risk management plans, etc.).</p>
C-2 Soils (> 19 but ≤ 95 mg/kg)	<p>Remedial actions vary depending on site-specific factors, including current and planned use, available options for onsite isolation or offsite disposal, and technical and economical constraints (see text). Potential actions include:</p> <p>Consider removal and offsite disposal of small, easily identifiable “hot spots” when possible in order to reduce the average concentration of bioaccessible arsenic on the property. Use of C-2 soils as daily cover at a regulated landfill may also be possible.</p> <p>For sites that have already been developed, consider a minimum one-foot cover of clean fill material if the soil cannot be removed. If capping of soil is not feasible, consider measures to reduce daily exposure to soil (e.g., maintain lawn cover, ensure good hygiene, etc.).</p> <p>For new developments, consider isolation of soil under buildings, private roads or other permanent structures if technically and economically feasible. If isolation under permanent structures is not feasible, consider a minimum one-foot cover of clean fill material. Maintain landscaping and lawns in open areas where soil will not be capped. Backfill utility corridors with clean fill material (e.g., R-1 soils) to avoid excavation and inappropriate reuse of contaminated soil in the future.</p> <p>Require formal, long-term institutional controls to restrict use of site to commercial/industrial purposes only and ensure appropriate management of soil if exposed in the future (e.g., inform potential buyers, deed covenants, risk management plans, etc.). All areas of capped soil should be delineated on a surveyed map of the property to be subsequently included in the risk management plan.</p>

Table 2. Soil categories and recommended actions for Commercial/Industrial Sites (cont.).

<p>C-3 Soils (>95 mg/kg)</p>	<p>Removal of soil at existing commercial/industrial sites strongly recommended. At a minimum, consider removal and offsite disposal of soil with concentrations of bioaccessible arsenic that approach or exceed 180 mg/kg (direct exposure action level for construction and trench workers). If C-3 soils cannot be removed for technical or economic reasons, consider a minimum one-foot cover of clean fill material (two feet in potential deep landscaping areas) and placement of an easily identifiable marker barrier between the clean fill and the underlying soil (e.g., orange construction fencing or geotextile/geonet material).</p> <p>For new developments, removal and offsite disposal of soil should be strongly considered. At a minimum, consider removal and offsite disposal of soil with concentrations of bioaccessible arsenic that approach or exceed 180 mg/kg (direct exposure action level for construction and trench workers).</p> <p>If offsite disposal is not feasible but redevelopment of the property is still desired, consider use of soil as structural fill under public buildings, private roads, or other paved and well-controlled structures. If capping in open areas is unavoidable, consider a one-foot minimum cap thickness with an easily definable marker barrier placed between the soil and the overlying clean fill (e.g., orange construction fencing or geotextile/geonet material). Backfill utility corridors with clean fill material (e.g., R-1 soils) to avoid excavation and inappropriate reuse of contaminated soil in the future.</p> <p>Require formal, long-term institutional controls to ensure appropriate management of soil in the future (e.g., inform potential buyers, deed covenants, risk management plans, etc.). All areas of capped soil should be delineated on a surveyed map of the property to be subsequently included in the risk management plan.</p>
--	--

The soil categories and arsenic action levels noted above are intended to be used as guidelines only and do not represent strict, regulatory cleanup requirements.

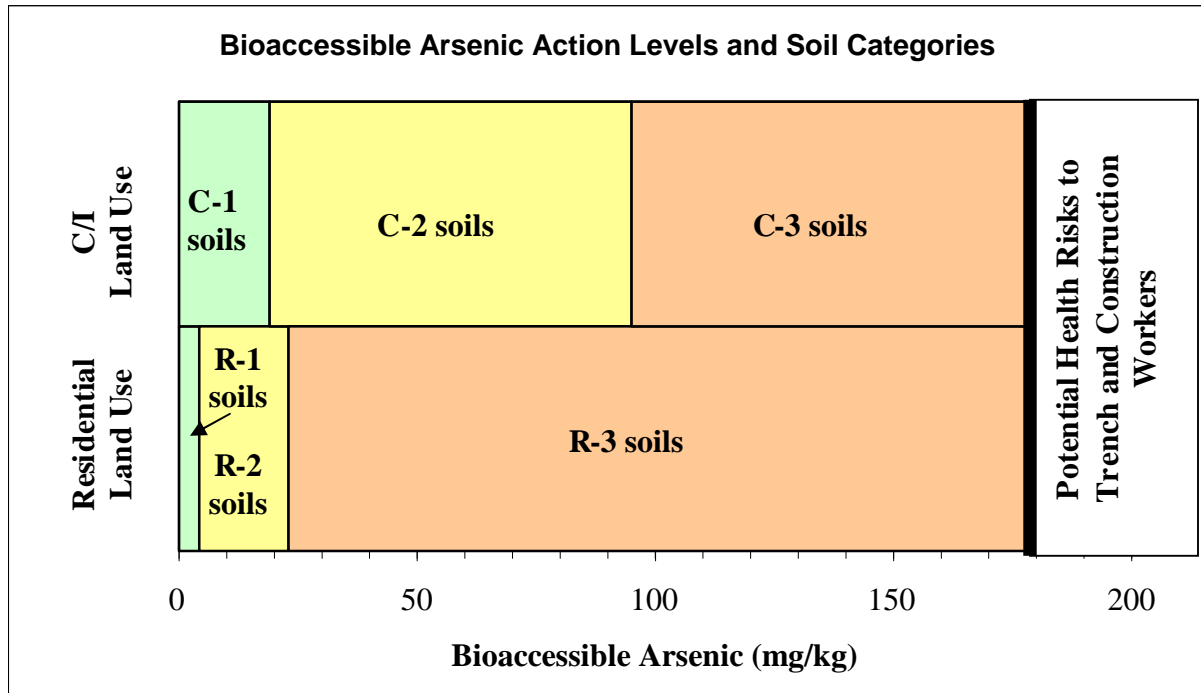

Residential Land Use Soil Categories		Commercial/Industrial Land Use Soil Categories	
R-1	≤4.2 mg/kg	C-1	≤19 mg/kg
R-2	>4.2 mg/kg to ≤23 mg/kg	C-2	>19 mg/kg to ≤95 mg/kg
R-3	>23 mg/kg	C-3	>95 mg/kg
>180 mg/kg: Potential risk to trench & construction workers			

Figure 1. Summary of bioaccessible arsenic action levels and correlative soil categories for residential and commercial/industrial (C/I) land-use scenarios.

ATTACHMENT 2

ESTIMATED DIETARY INTAKE
OF TOTAL AND INORGANIC ARSENIC FOR PACIFIC-ASIAN DIETS

Dietary Exposure to Arsenic

A review of dietary exposure to total and inorganic arsenic was carried out by estimating daily consumption of the following food groups and typical concentrations of arsenic associated with each group:

- cereals & cereal products;
- starch roots and tubers;
- sugars and syrups;
- fats and oils;
- fish, meat and poultry;
- eggs;
- milk and products;
- dried beans, nuts and seeds;
- vegetables;
- fruits; and
- miscellaneous (beverages, condiments, etc.).

Consumption rates of each food group in a typical Filipino diet were compiled based on information published by the Philippine government and used as a surrogate for a typical Pacific-Asian diet (FNRI 2003, see Tables 1 and 2). Data are provided for children (ages 1-5) and the population as a whole (essentially adults). The data are provided for “As Purchased” food (e.g., raw vegetables, uncooked rice, etc.). A summary of the data is provided in Table 1.

Typical concentrations of inorganic and total arsenic in each food group were taken from a study of dietary exposure to arsenic in US children (Schoof et al. 1999, as presented in Yost et al. 2004; refer to Table 2). The data are based on prepared food (i.e., cooked meats and vegetables, including rice). While this is unlikely to introduce significant bias for meats and raw vegetables, the arsenic data for cooked rice cannot be directly compared to consumption data for uncooked rice. As an alternative, the estimated concentration of arsenic in rice is based on the average of 11 types of uncooked rice tested in a separate study (Williams et al 2005, as presented in Juhasz et al. 2006; refer to Table 1). Estimated concentrations of inorganic and total arsenic in seaweed was taken from a study carried out by the United Kingdom Food Standards Agency (UKFSA 2004).

The estimated daily, dietary intake of total arsenic is summarized in Figure 1. The estimated daily intake of inorganic arsenic is summarized in Figure 2. For children age one to five, the average exposure to dietary inorganic arsenic is estimated to be 18 ug/day, with 95% of the arsenic coming from rice. For the mean population (assumed representative of adults in general), the average exposure to dietary inorganic arsenic is estimated to be 44 ug/day, with a similar proportion of the arsenic coming from rice.

Dietary total arsenic is significantly higher, due primarily to the anticipated high consumption of fish and seaweed and the relatively high levels of organic arsenic in these foods. As noted in Table 1 and Figure 1, the average dietary total arsenic for children ages 1-5 is estimated to be 176 ug/day and for the mean population 339 ug/day. The

consumption of fish provides approximately 75% of the total dietary arsenic, with the remainder of the total arsenic contributed by rice and seaweed (Nori seaweed assumed). Although organic arsenic is not considered to be significantly toxic, metabolism to DMA could complicate interpretation of the urine data collected for the target Filipino population.

References

- Cutler, W.; Hue, N.; Ortiz-Escobar, M. and T. Martin, 2006, Approaches to Reduce Bioaccessible Arsenic in Hawai'i Soils: *in* Bruce M. Sass (Conference Chair), Remediation of Chlorinated and Recalcitrant Compounds, Paper H-36, Proceedings of the Fifth International Conference on Remediation of Chlorinated and Recalcitrant Compounds (Monterey, California; May 2006), Battelle Press, Columbus, OH, ISBN 1-57477-157-4, <http://www.hawaii.gov/health/environmental/hazard/eal2005.html>
- FNRI, 2003, The 6th National Nutrition Survey: Food, Philippine Department of Science and Technology, Nutrition and Research Institute, <http://www.fnri.dost.gov.ph/index.php?option=content&task=view&id=1130>
- HDOH, 2007, Kea'au Soil Arsenic Assessment Study: State of Hawai'i Department of Health Hazard Evaluation and Emergency Response (HEER) Office, December 2007.
- Juhasz, A.L. et. al., 2006, In Vivo Assessment of Arsenic Bioavailability in Rice and Its Significance for Human Health Risk Assessment: Environmental Health Perspectives, Volume 114, No. 12, December 2006, pp 1826-1831.
- UKFSA, 2004, Arsenic in seaweed: United Kingdom Food Standards Agency, Fact Sheet <http://www.food.gov.uk/science/surveillance/fsis2004branch/fsis6104>
- USEPA, 2004, *Preliminary Remediation Goals*: U.S. Environmental Protection Agency, Region IX, October 2004, www.epa.gov/region09/waste/sfund/prg/index.htm.
- Williams, P.N., et al., 2005, Variation in arsenic speciation and concentration in paddy rice related to dietary exposure: Environmental Science Technology, Vol. 39:5531-5540.
- Yost et al., 2004, Estimation of Dietary Intake of Inorganic Arsenic in U.S. Children: Human and Ecological Risk Assessment, Vol. 10: 473-483.

Table 1. Estimation of dietary exposure to total arsenic for a typical Filipino diet (surrogate for Pacific-Asian diet).

Food Group	¹ Child Consumption (g/d)	¹ Mean Consumption (g/d)	Total Arsenic (ug/kg)	Child (6mo-5yr)		Mean Population		² Reference	Comments
				Daily Dose (ug/d)	Percent Total Arsenic Contribution	Daily Dose (ug/d)	Percent Total Arsenic Contribution		
Cereals	166	364		27.09	15.40%	65.4	19.28%		
Rice & Products	122	303	208	25.4	14.42%	63	18.58%	Williams et al 2005	<i>in</i> Juhasz et al 2006
Corn and Products	17	31	38.6	0.66	0.37%	1.20	0.35%	Yost et al., 2004	
Other Cereals and Products	27	30	39.2	1.06	0.60%	1.18	0.35%	Yost et al., 2004	flour
Starch Roots and Tubers	8	19	2.8	0.02	0.01%	0.05	0.02%	Yost et al., 2004	potatoes
Sugars and Syrups	15	24	23.8	0.36	0.20%	0.57	0.17%	Yost et al., 2004	cane sugar
Fats and Oils	6	18	1.8	0.01	0.01%	0.03	0.01%	Yost et al., 2004	butter
Fish, Meat & Poultry	95	185		135.61	77.08%	247.58	73.00%	Yost et al., 2004	
Fish and Products	57	104	2356	134.29	76.34%	245.02	72.25%	Yost et al., 2004	Saltwater fish (Freshwater = 160 ug/kg)
Meat and Products	27	61	13.5	0.36	0.21%	0.82	0.24%	Yost et al., 2004	pork
Poultry and Products	11	20	86.40	0.95	0.54%	1.73	0.51%	Yost et al., 2004	chicken
Eggs	8	13	0.98	0.01	0.00%	0.01	0.00%	Yost et al., 2004	
Milk and Products	179	49		0.39	0.22%	0.11	0.03%	Yost et al., 2004	
Whole Milk	158	35	2.2	0.35	0.20%	0.08	0.02%	Yost et al., 2004	
Milk Products	21	14	2.2	0.05	0.03%	0.03	0.01%	Yost et al., 2004	
Dried Beans, Nuts & Seeds	4	10	43.7	0.17	0.10%	0.44	0.13%	Yost et al., 2004	
Vegetables	23	111		12.08	6.87%	24.65	7.27%	Yost et al., 2004	
Green Leafy & Yellow	10	31	6.1	0.06	0.03%	0.19	0.06%	Yost et al., 2004	spinach
Other Vegetables	3	80	5.8	0.02	0.01%	0.46	0.14%	Yost et al., 2004	average all other vegetables
Seaweed	0.5	1	24,000	12.00	6.82%	24.00	7.08%	UKSFA 2004	nori seaweed (1/2 MRL of 0.3 mg/kg)
Fruits	31	54		0.16	0.09%	0.26	0.08%	Yost et al., 2004	
Vitamin C-rich Fruits	4	12	2.5	0.01	0.01%	0.03	0.01%	Yost et al., 2004	oranges
Other Fruits	27	42	5.5	0.15	0.08%	0.23	0.07%	Yost et al., 2004	average all other fruits
Miscellaneous	27	39		0.02	0.01%	0.03	0.01%	Yost et al., 2004	
Beverages	26	26	0.8	0.02	0.01%	0.02	0.01%	Yost et al., 2004	tapwater used in cooking
Condiments & Others	1	13	0.8	0.001	0.0005%	0.01	0.003%	Yost et al., 2004	salt
Total Food Consumption:	562	886	Total:	176	100.0%	339	100.0%		

1. FNRI, 2003. Child = Average 6mo to 5 yrs. "As Purchased," cereals presumable dry weight.

2. See text for full reference.

Table 2. Estimation of dietary exposure to inorganic arsenic for a typical Filipino diet (surrogate for Pacific-Asian diet).

Food Group	¹ Child Consumption (g/d)	¹ Mean Consumption (g/d)	Inorganic Arsenic (ug/kg)	Child (6mo-5yr)		Mean Population		Reference	Comments
				Daily Dose (ug/d)	Percent Inorganic Arsenic Contribution	Daily Dose (ug/d)	Percent Inorganic Arsenic Contribution		
Cereals	166	364		17.33	96.6%	42.6	97.5%		
Rice & Products	122	303	139.0	17.0	94.6%	42	96.4%	Williams et al 2005	<i>in</i> Juhasz et al 2006
Corn and Products	17	31	4.4	0.07	0%	0.14	0%	Yost et al., 2004	
Other Cereals and Products	27	30	10.9	0.29	2%	0.33	1%	Yost et al., 2004	flour
Starch Roots and Tubers	8	19	0.8	0.01	0.0%	0.02	0.0%	Yost et al., 2004	potatoes
Sugars and Syrups	15	24	4.4	0.07	0%	0.11	0.2%	Yost et al., 2004	cane sugar
Fats and Oils	6	18	1.2	0.01	0.0%	0.02	0.0%	Yost et al., 2004	butter
Fish, Meat & Poultry	95	185		0.08	0.5%	0.16	0.4%	Yost et al., 2004	
Fish and Products	57	104	1.0	0.06	0.3%	0.10	0.2%	Yost et al., 2004	Saltwater fish (Freshwater = 160 ug/kg)
Meat and Products	27	61	0.67	0.02	0.1%	0.04	0.1%	Yost et al., 2004	pork
Poultry and Products	11	20	0.89	0.01	0.1%	0.02	0.0%	Yost et al., 2004	chicken
Eggs	8	13	0.98	0.01	0.0%	0.01	0.0%	Yost et al., 2004	
Milk and Products	179	49		0.18	1.0%	0.05	0.1%	Yost et al., 2004	
Whole Milk	158	35	1.0	0.16	0.9%	0.04	0.1%	Yost et al., 2004	
Milk Products	21	14	1.0	0.02	0.1%	0.01	0.0%	Yost et al., 2004	
Dried Beans, Nuts & Seeds	4	10	4.7	0.02	0.1%	0.05	0.1%	Yost et al., 2004	
Vegetables	23	111		0.14	0.8%	0.54	1.2%	Yost et al., 2004	
Green Leafy & Yellow	10	31	6.1	0.06	0.3%	0.19	0.4%	Yost et al., 2004	spinach
Other Vegetables	3	80	2.6	0.01	0.0%	0.21	0.5%	Yost et al., 2004	average all other vegetables
Seaweed	0.5	1	150	0.08	0.4%	0.15	0.3%	UKSFA 2004	nori seaweed (1/2 MRL of 0.3 mg/kg)
Fruits	31	54		0.07	0.4%	0.12	0.3%	Yost et al., 2004	
Vitamin C-rich Fruits	4	12	2.5	0.01	0.1%	0.03	0.1%	Yost et al., 2004	oranges
Other Fruits	27	42	2.1	0.06	0.3%	0.09	0.2%	Yost et al., 2004	average all other fruits
Miscellaneous	27	39		0.02	0.1%	0.03	0.1%	Yost et al., 2004	
Beverages	26	26	0.8	0.02	0.1%	0.02	0.0%	Yost et al., 2004	tapwater used in cooking
Condiments & Others	1	13	0.8	0.001	0.00%	0.01	0.02%	Yost et al., 2004	salt
Total Food Consumption:	562	886	Total DD:	18		44			

1. FNRI, 2003. Child = Average 6mo to 5 yrs. "As Purchased," cereals presumable dry weight.

2. See text for full reference.

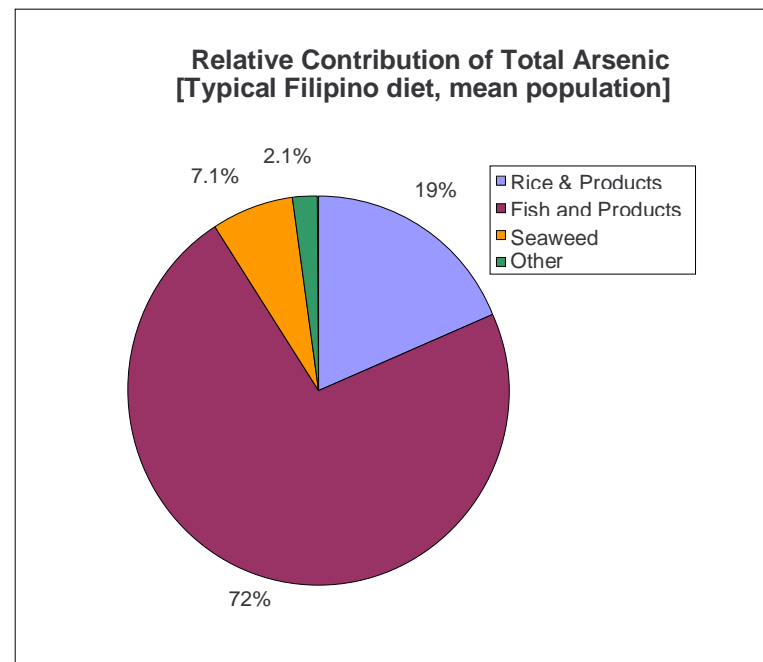
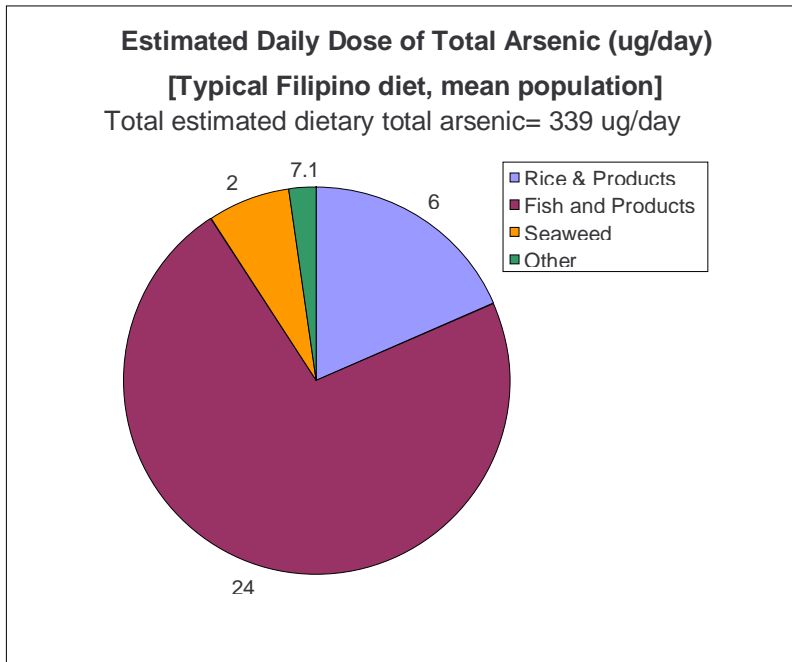
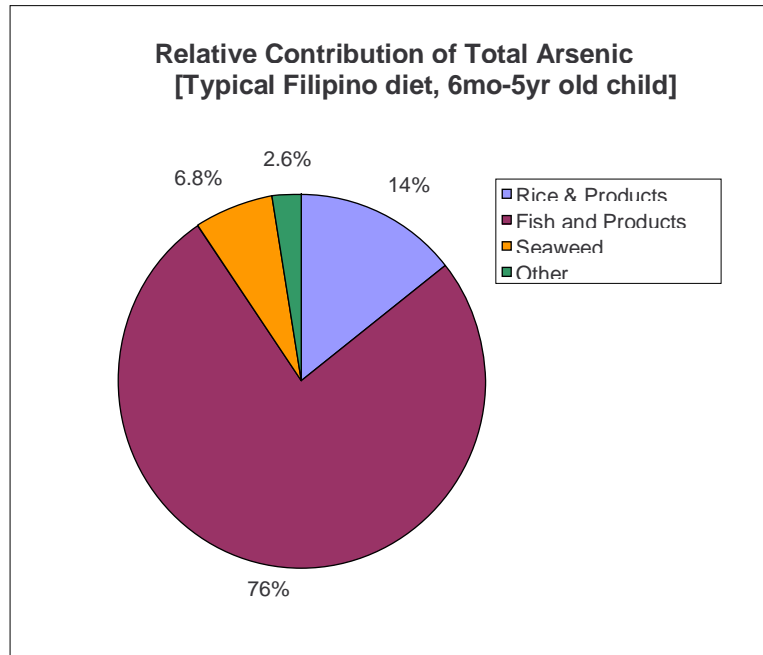
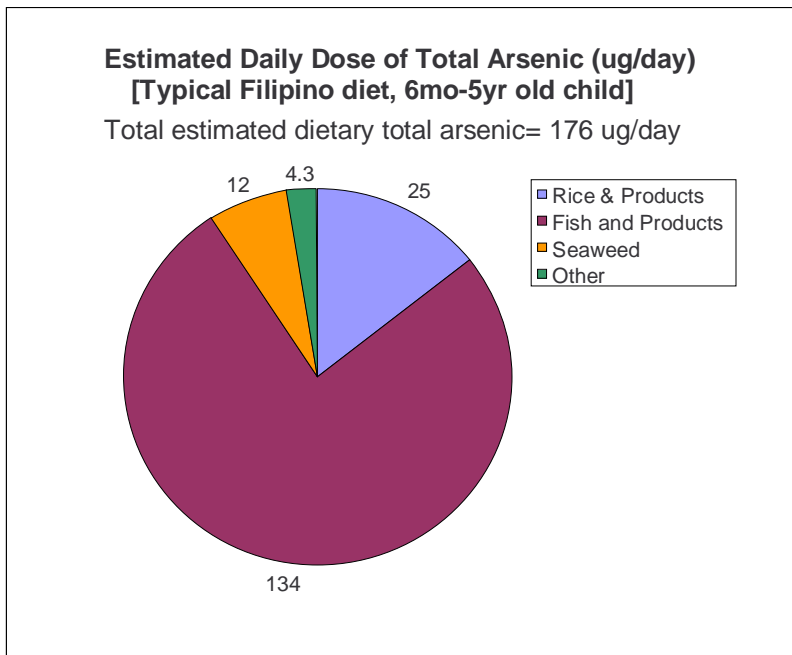

Figure 1. Estimated total arsenic intake based on a typical Filipino diet (surrogate for Pacific-Asian diet, refer to Table 1).

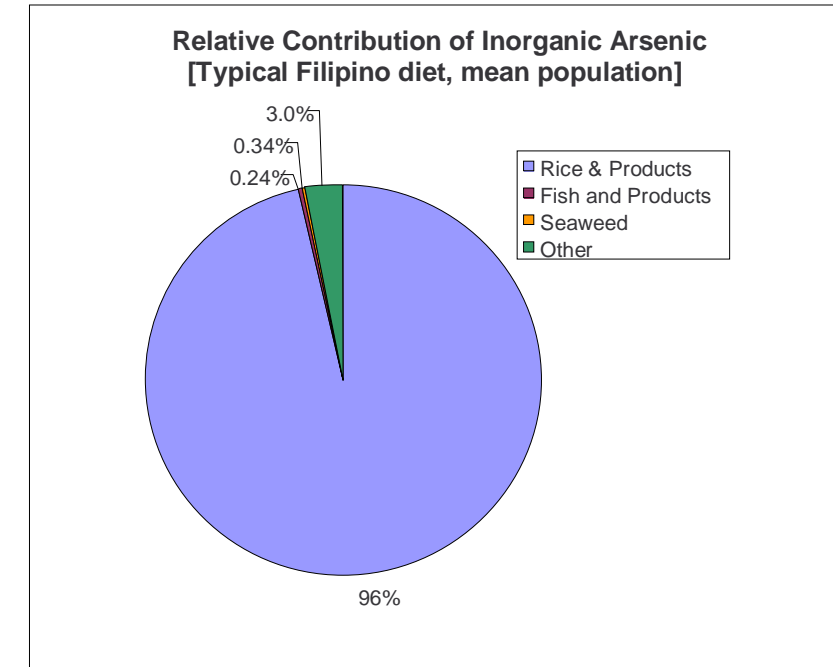
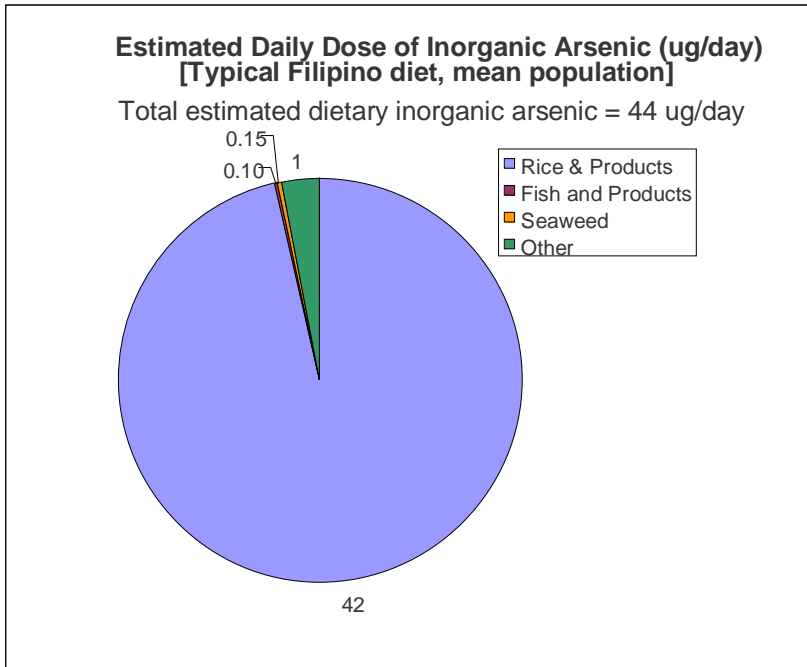
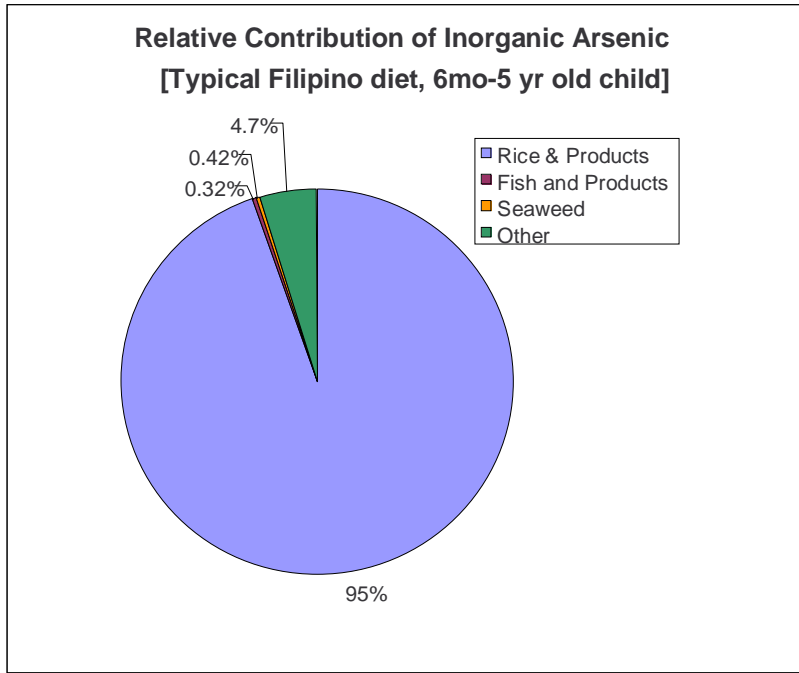
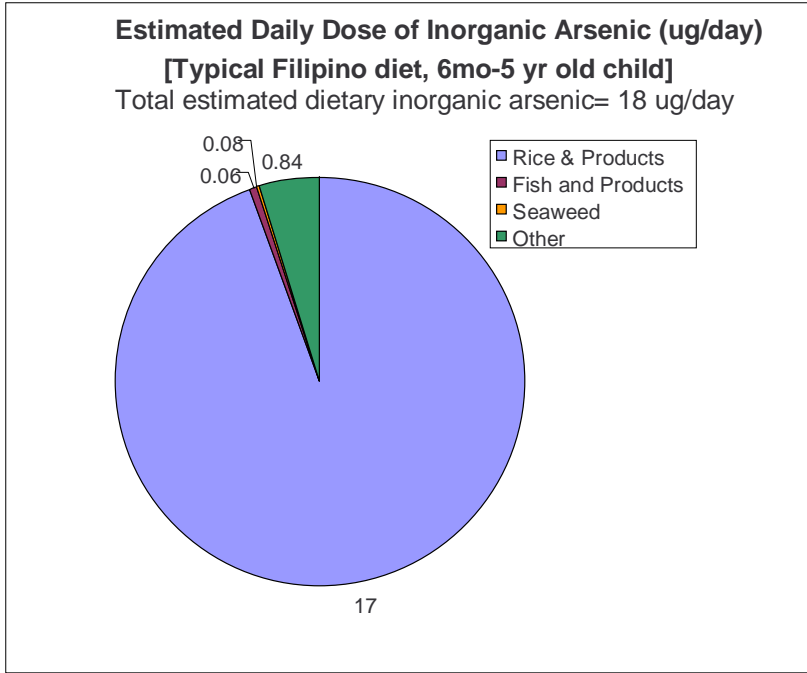

Figure 2. Estimated inorganic arsenic intake based on a typical Filipino diet (surrogate for Pacific-Asian diet, refer to Table 2).

LINDA LINGLE
GOVERNOR OF HAWAII



CHIYOME LEINA'ALA FUKINO, M.D.
DIRECTOR OF HEALTH

STATE OF HAWAII
DEPARTMENT OF HEALTH
P.O. Box 3378
HONOLULU, HAWAII 96801-3378

In reply, please refer to:
File: EHA/HEER Office
2010-389-RB

June 2010

To: Interested Parties

From: Roger Brewer, Ph.D., Environmental Risk Assessor, HEER *RB*

Through: Barbara Brooks, Ph.D., Toxicologist, HEER *SB*

Subject: Update to Soil Action Levels for TEQ Dioxins and Recommended Soil Management Practices

1.0 Introduction

This technical memorandum presents an update to Hawai'i Department of Health (HDOH) action levels and corresponding guidance for dioxins and furans ("dioxins") in soil. This guidance serves as an addendum to the Hazard Evaluation and Emergency Response (HEER) office document *Evaluation of Environmental Hazards at Sites with Contaminated Soil and Groundwater* (EHE guidance; HDOH 2008a). A summary of the updated action levels and soil management categories is provided in Table 1. A detailed discussion of the development and support of the action levels is provided in Attachment 1 (Supplemental Information), Attachment 2 (Exposure Models) and Attachment 3 (Dietary Exposure to Dioxins).

This guidance supersedes and takes precedence over a technical memorandum on dioxins published by the HEER office in June 2008 and incorporated into the EHE guidance (HDOH 2008b). This memo also presents a modification of the HEER office soil categorization system, based on updates to dioxin action levels and a simplified approach for classification and management of dioxin-contaminated soils. The soil action levels presented herein are not promulgated regulatory standards or required cleanup levels. Alternative proposals may be presented in a site-specific risk assessment. However, the nature of the toxicity factors and exposure assumptions used to in this update are unlikely to allow significant flexibility for less stringent, site-specific action levels in the absence of institutional and/or engineering controls.

The soil action levels presented in this document are intended for comparison to soil data obtained through collection of multi-increment ("incremental") soil samples, as described in the HEER office *Technical Guidance Manual* (HDOH 2009). When combined with *Decision Unit* investigation approaches, multi-increment soil samples offer a more cost-effective and efficient

approach for characterization of a targeted area or volume of soil than traditional, discrete sample approaches. Studies have shown that a small number (e.g., less than <30) of discrete samples is unlikely to adequately capture contaminant heterogeneity and small “hot spots” of elevated contaminant concentrations within a targeted area (e.g., Ramsey et. al. 2005; Jenkins et al. 2005). This can lead to an underestimate of exposure point concentrations for risk assessment purposes, as well as an underestimate of contaminant mass for *in situ* or *ex situ* treatment. Alternative soil sampling schemes should be discussed with the HEER office on a site-by-site basis.

2.0 Updated HDOH TEQ Dioxin Soil Action Levels

The updated Toxicity Equivalent (TEQ) dioxin soil action levels are as follows:

2010 HDOH TEQ Dioxin Soil Action Levels	
≤240 ng/kg	No significant risk to human health under unrestricted (e.g., residential) land use.
≤1,500 ng/kg	No significant risk to human health under commercial/industrial land use (also used as the construction/trench worker action level).

As discussed in Attachments 1-3, the development and justification of the updated soil action levels are based on the following multiple lines of evidence:

- Predominance of less-toxic forms of dioxins in soil (tetrachlorodibenzo-*p*-dioxin or TCDD, generally <<1%);
- Reduced relative bioavailability of dioxins in soil in comparison to published toxicity studies (assumed 60%);
- Uncertainty in published and proposed cancer slope factors and noncancer reference doses for TCDD;
- HDOH preference for the World Health Organization (WHO) body burden approach to evaluate potential health risks posed by chronic exposure to dioxins;
- Comparability of WHO Permissible Tolerable Intake factors for TEQ dioxins to published and draft toxicity factors for health risks published by the U.S. Environmental Protection Agency (USEPA) and other parties;
- Use of WHO Toxicity Equivalent Factors to estimate health risks from non-TCDD dioxins and furans;
- Consideration of typical dietary intake of dioxins with respect to theoretical risk posed by exposure to soil;
- Lack of a significant, added health benefit from the use of lower action levels to further reduce exposure to dioxins in soil;
- HDOH’s acknowledgment that remediation of large tracts of agricultural lands where trace levels of dioxins associated with the past use of pentachlorophenol and other agricultural practices have been identified is impractical and unnecessary from a health risk perspective; and

- Recommendation to remediate localized spill areas of heavy dioxin contamination to surrounding background when feasible rather than reliance on purely risk-based action levels.

The updated action levels are used in Section 3 of this technical memorandum to redefine the soil management categories originally presented in the 2008 HEER guidance. Reduction of the soil action level for unrestricted land use from 450 ng/kg, as presented in the 2008 HEER guidance, to 240 ng/kg is not considered to be a significant change from the standpoint of potential risk to human health. HEER does not foresee the need to reopen cases closed under the 2008 action levels or require additional sampling at sites where investigations carried out under the previous guidance have already been completed. For isolated spill areas at sites where remedial action plans have not been finalized or completed, however, parties are encouraged to include *all* soil contaminated above surrounding background in remedial actions to the extent practicable (refer to Section 4).

3.0 Dioxin Soil Management Categories

Updated categories for the evaluation and management of dioxin-contaminated soil are summarized below and summarized in Table 1. These categories replace the scheme presented in the 2008 HEER guidance:

Category A Soils (natural background): Soils exhibit concentrations of TEQ dioxins <20 ng/kg, and do not appear to have been impacted by local, agricultural or industrial releases of dioxin. These soils represent “background” dioxin levels in the absence of agricultural or industrial impacts. Data on dioxins in native, un-impacted soils in Hawai‘i are limited, especially when compared to data on metals (e.g., arsenic). However, based on recent investigations overseen by HEER, the background level of TEQ dioxins in soils in Hawai‘i that have not been impacted by modern agricultural or industrial activities appears to be <20 ng/kg.

Category B Soils (minimally impacted): Soils exhibit concentrations of TEQ dioxins between 20 ng/kg and 240 ng/kg, indicating anthropogenic impacts at levels that are detectable but not considered harmful. HEER expects Category B soils to be generally associated with agricultural fields where dioxin-bearing pesticides were routinely applied in the past. Dioxin levels measured in soils in former agricultural fields range from <20 ng/kg to 100 ng/kg, and up to 200 ng/kg in some areas. HEER believes these dioxins typically represent residues of past applications of pentachlorophenol as an herbicide in sugarcane fields although burning of the fields may have also contributed. At most sites, the pentachlorophenol has degraded to below detectable levels, leaving behind a low-level residue of dioxins. For further discussion, see Section 9 in the HEER *TGM* (HDOH 2009).

Category C Soils (moderately impacted): Soils exhibit concentrations of TEQ dioxins between 240 ng/kg and 1,500 ng/kg. Category C soils are exemplified by contamination at former pesticide storage and mixing areas that included the use of pentachlorophenol and similar pesticides. Soils associated with burn pits or impacted by incinerator ash are also likely to fall into this category.

Category D Soils (heavily impacted): Soils have dioxin concentrations exceeding 1,500 ng/kg. Category D soils are exemplified by heavy contamination at former pesticide mixing areas associated with the use of pentachlorophenol. Concentrations of TEQ dioxins in soil between 10,000 ng/kg and 100,000 ng/kg are not uncommon, with concentrations up to 1,000,000 ng/kg reported at some facilities (>500 mg/kg total dioxins/furans). Pentachlorophenol is typically present at significantly lower concentrations or even below laboratory reporting limits.

4.0 Management of Dioxin-Contaminated Soils

HEER offers the following observations and recommendations for the short-term and long-term management of dioxin-contaminated soil, based on experience with past dioxin response sites.

4.1 Site Characterization

Long-term management of soil with greater than 240 ng/kg TEQ dioxins (or other, approved action levels) will be required at all sites where treatment or removal of this soil is not carried out. Investigation of the site should characterize the lateral and vertical extent of soil contaminated above this action level to the extent practicable, regardless of the current land use of the site, unless otherwise approved by HEER. This includes the need to identify and include Category B soils at commercial/industrial sites in an *Environmental Hazard Management Plan* prepared for that property, even though these soils do not pose a significant health risk to site workers. This will help ensure that the soil is not inadvertently excavated and reused at a more sensitive, offsite location during future subsurface or redevelopment work (e.g., reuse as fill material for a school yard). Potential disposal and management requirements under State and USEPA hazardous waste regulations must also be evaluated and documented.

4.2 Remedial Options

Remedial options typically considered at dioxin response sites are, in order of descending preference, **treatment, off-site disposal, engineered controls** and **institutional controls**.¹ As discussed in Section 4.3, the added cost of long-term management and potential liability for inappropriate exposure or reuse of the soil in the future should be taken into consideration in the selection of a final remedy.

4.2.1 Treatment

In situ or *ex situ* thermal treatment is considered to be the state-of-the-art method for the destruction of dioxins in contaminated soils, although numerous other remedial options have also

¹ State regulations list remedial options for contaminated soils in the following order of descending preference, to the extent practicable: (a) reuse or recycling; (b) destruction or detoxification; (c) separation, concentration, or volume reduction, followed by reuse, recycling, destruction or detoxification of the residue; (d) immobilization; (e) on-site or off-site disposal, isolation, or containment at an engineered facility in accordance with applicable requirements; and (f) institutional controls or long term monitoring [Hawai'i Administrative Rules 11-451-8(c)(2)].

been proposed (e.g., Haglund 2007, Kulkarni 2008). The number of companies and facilities that offer thermal treatment is very limited, however, and the cost of thermal treatment can far exceed the short-term costs for other remedial options. For example, the cost to excavate and ship 5,000+ tons of dioxin-contaminated soil from a former pesticide mixing area (PMA) site on O‘ahu to treatment facilities in North America was recently estimated to exceed \$3,000/ton. *In situ* thermal treatment of the soil was estimated to approach \$1,000/ton. The initial cost to construct an engineered cap over the soil is approximately one-tenth of the total cost for *in situ* treatment.

Treatment of Category D, dioxin-contaminated soil will, in many cases, only be feasible as part of large-scale redevelopment projects that can generate adequate capital funds for this option, e.g., by amortization of cleanup cost, concessions on the land purchase price and/or marginal increases in sales prices of new homes. Capping of the soil at currently unused sites will be necessary in many cases (see *Engineered Controls*). If so, the soil should be capped in an area that will remain accessible for possible removal or *in situ* treatment should cheaper, on-island alternatives come become available in the future (e.g., under parking lots or other open areas, versus under a permanent building). This will allow the property owner and/or responsible party to access and treat the soil in order if they so desire, in order to remove liabilities and depreciation in property value posed by continued long-term management of the soil.

4.2.2 Disposal

Disposal of dioxin-contaminated soil in a permitted landfill is a potentially cost-effective option for remediation of isolated spill areas. As discussed in Section 4.4, however, dioxin-contaminated soil must be evaluated for potential Resource Conservation and Recovery Act (RCRA) Subtitle C hazardous waste restrictions prior to disposal. If the soil is determined to be a hazardous waste, then it cannot be disposed of in a local landfill. If the soil is determined to not be a hazardous waste, then it may be disposed in a municipal landfill or construction & demolition debris landfill, contingent upon acceptance by the landfill operator. Municipal landfills may also be reluctant to accept heavily contaminated soil for disposal due to worker exposure and future liability concerns.

4.2.3 Engineered Controls

The risk posed by dioxin-contaminated soils can be addressed via on-site construction of a physical barrier (a “cap”) to protect the public and the environment from exposure. Containment-based remedies require long-term maintenance and monitoring to ensure the continued integrity of the cap and effectiveness of the remedy. Protocols for long-term management should be included in an *Environmental Hazard Management Plan* prepared for the site, as described in the HEER *Technical Guidance Manual* (HDOH 2009). Specific cap designs will vary depending on site-specific conditions and redevelopment plans.

A clearly identifiable marker barrier (e.g., orange plastic construction fencing) is generally placed between the contaminated soil and the overlying clean fill material. HEER also recommends that a grid of durable, detectable (metallic) and labeled underground warning tape

be placed on top of dioxin-contaminated soils as part of a long-term cap. Similar to the procedures used when burying natural gas pipelines, warning messages and contact information should be printed on the warning tape, for example: “**CAUTION – STOP DIGGING! DIOXIN-CONTAMINATED SOIL BELOW! CONTACT _____ at _____ FOR FURTHER INFORMATION.**” The cost for this type of customized warning tape is approximately \$200 per 1,000-foot roll; and is available from Safety Systems of Hawai‘i among other vendors.

As discussed above, it is preferable that heavily contaminated soil be capped in an area that will allow access for removal or *in situ* treatment in the future should cheaper, on-island alternatives become available. For additional information, consult the HEER *Technical Guidance Manual* (HEER 2009) and contact HEER staff. HEER plans to update its capping guidance in the near future based on experience gained from current studies.

4.2.4 Institutional controls

Dioxin-contaminated sites may be addressed by the use of institutional controls (ICs) to protect the public and the environment from exposure. For example, use of the property for residences, schools, day care, medical facilities or other sensitive purposes can be restricted in a formal covenant to the deed. Excavation in contaminated areas or reuse of soil from the site without the express consent of HDOH can also be prohibited. Additional information on institutional controls is provided in the HEER *Technical Guidance Manual* (HEER 2009).

4.3 Management of Category C Soils at Commercial/Industrial Sites

Category C soils are not considered to pose health risks under commercial/industrial land use but could pose potential risks under residential or other sensitive land uses. Long-term management of these soils is therefore required if left in place at a commercial/industrial site. Specific issues associated with the long-term management of Category C soils are discussed below.

4.3.1 Include Institutional Controls in EHMPs

Category C soils can be managed in place at commercial/industrial sites with minimal engineering controls provided that care is taken to prevent offsite movement of the soils via windblown dust, storm water runoff and other processes. As discussed in above, however, a potential exists for the inadvertent excavation of these soils, transport to unrestricted/residential land use areas (e.g., schools or residential areas) and reuse of these soils as fill material in areas where the soil could then pose a health risk. Institutional controls should, therefore, be included as one part of the *Environmental Hazard Management Plan* prepared for a commercial/industrial site where Category C soils are left in place.

4.3.2 Include Soil Above Surrounding Background in Remediation of Category D Soils

From a purely risk assessment standpoint, redevelopment of a heavily contaminated site for commercial/industrial purposes only requires remediation of Category D soils, although Category C soils must be managed properly. The boundary between localized “hot spots” of

heavily contaminated soil and the surrounding soils is typically very sharp, however, with a rapid drop off in contaminant concentrations to background (i.e., <20 ng/kg for non-agricultural soils and 20-100 ng/kg for former field areas). The additional area and volume of marginally impacted soil that lies at the margins of the heavily contaminated area will, in many instances, be relatively minor. The inclusion of *all* soil contaminated by the release above the surrounding background in remediation actions is therefore recommended, to the extent practicable, even though the marginally contaminated soil may not pose a significant risk to future users of the site under commercial/industrial land use.

At sites where Category D soils are to be addressed via treatment, disposal, or containment, HEER recommends that the same remedy be used for the full area and volume of soil that is clearly above background for the surrounding area to the extent practicable, for the following reasons:

1. **The added cost of addressing less contaminated soils along with heavily contaminated soils is anticipated to be relatively small.** As described above, sites characterized by isolated spill areas of highly-contaminated soils are typically sharply defined. An expansion of the boundary of the remediation area to include Category C and even Category B soils that are clearly above the surrounding background may significantly increase the long-term reliability of the remedy without an excessive increase in short-term remediation cost and decrease the cost and liability associated with long-term management of the site.
2. **Engineered and institutional controls can be more expensive than initially estimated.** Low up-front capital costs for on-site, long-term management of moderately contaminated soil can mask costs associated with long-term maintenance and oversight of controls as well as future liability associated with inappropriate onsite or offsite reuse of inadvertently exposed soil. This underestimation of the total life-cycle cost can lead to the selection of a remedy that either (1) fails due to inadequately-funded implementation, or (2) ends up exceeding the costs of other remedial options that had been deemed too expensive during the initial evaluation. Full treatment of contaminated soil will also increase the future resale and development value of the property.

Short and long-term remedial actions for sites where Category D soils are identified should be discussed with the HEER office on a site-by-site basis.

4.4 Hazardous Waste Considerations

Hazardous waste issues associated with the long-term management of dioxin-contaminated soil should be discussed with HEER staff on a site-by-site basis and incorporated into an *Environmental Hazard Management Plan* prepared for the site. The burden and feasibility of long-term management of dioxin-contaminated soil at a site can vary greatly depending on the regulatory designation of the soil as a hazardous or nonhazardous waste under RCRA Subtitle C. Dioxin-contaminated soil that is designated as a hazardous waste (see below) cannot be disposed of in any of the permitted, municipal waste landfill or construction and demolition debris landfill

in Hawai'i. The soil must instead be disposed of at an out-of-state hazardous waste facility, typically at a significantly greater cost and administrative burden. This issue should be considered in selection of a final remedy for a site.

A preliminary Land Disposal Restriction (LDR) determination under RCRA Subtitle C should be made for dioxin-contaminated soils identified in the course of a site investigation (e.g., USEPA 2005). Dioxins associated with the release of a listed waste under RCRA Subtitle C are considered to be hazardous waste at the point that the soil is excavated or "generated." An example is dioxin-contaminated soil at a wood treatment facility that is associated with the release of pentachlorophenol. If the soil is not excavated then it is not considered to be "generated" and is therefore not subject to an LDR determination. If excavated, the soil is considered to be contaminated with a prohibited waste and must be managed in accordance with LDR restrictions.

Pesticide-contaminated soil associated with past agricultural practices is *exempt* from designation as a hazardous waste, provided that the pesticide was used as intended and containers were cleaned and disposed of in accordance with label information available at that time (40 CFR §262.70 Subpart G: Farmers; USEPA 1986, 2006). This exemption applies to both field areas and pesticide mixing areas. Dioxin-containing soil associated with these types of agricultural sites does not fall under RCRA Subtitle C regulation unless it otherwise fails a hazardous waste characteristics test for other contaminants in the soil (e.g., ignitability, corrosivity, reactivity or exceedence of Toxic Characteristics Leaching Procedure (TCLP) regulatory levels; 40 CFR §261). Note that this exemption will not generally apply to illegal dump sites where disposal of bulk pesticides (vs cleaned containers) occurred. Applicability of this exclusion should be clearly discussed in a site-specific *Environmental Hazard Management Plan* for dioxin-contaminated soil that is capped in place for long-term management, with reference made to the above documents (e.g., 40 CFR §262.70 Subpart G: Farmers; USEPA 1986, 2006) as well as other pertinent information (e.g., past use of subject site for agricultural purposes). Simple reference of this technical memorandum will not be adequate.

References:

ATSDR, 1998, *Toxicological Profile for Chlorinated Dibenzo-p-dioxins (CDDs)*. Agency for Toxic Substances and Disease Registry, December 1998.

<http://www.atsdr.cdc.gov/toxprofiles/tp104.html>.

ATSDR, 2008, *Update to the ATSDR Policy Guideline for Dioxins and Dioxin-Like Compounds in Residential Soil*. Agency for Toxic Substances and Disease Registry, November 2008.

<http://www.atsdr.cdc.gov/substances/dioxin/policy/>.

Cole , P., Trichopoulos , Pastides, H., Starr, T and J.S. Mandel, 2003, Dioxin and cancer: a critical review: *Regulatory Toxicology and Pharmacology*, Vol. 38, p.378–388.

- Haglund, p., 2007, *Methods for Treating Soils Contaminated with Polychlorinated Dibenzo-p-Dioxins, Dibenzofurans, and Other Polychlorinated Aromatic Compounds*: *Ambio* Vol. 36, No. 6, September 2007, p476-474.
- HDOH, 2008a, *Tier 2 Action Levels for TEQ dioxins (update to March 23, 2006 memorandum)*. Hawai'i Department of Health, Hazard Evaluation and Emergency Response Office.
- HDOH, 2008b, *Evaluation of Environmental Hazards at Sites with Contaminated Soil and Groundwater (Summer 2008, updated March 2009)*. Hawai'i Department of Health, Hazard Evaluation and Emergency Response Office, March 2009.
<http://www.hawaii.gov/health/environmental/hazard/eal2005.html>.
- HDOH, 2009, *Technical Guidance Manual for the Implementation of the Hawai'i State Contingency Plan*. Hawai'i Department of Health, Hazard Evaluation and Emergency Response Office, <http://www.hawaiidoh.org>.
- Jenkins, T., et al., 2005. Representative Sampling for Energetic Compounds at Military Training Range: *Environmental Forensics*, Volume 6, pp. 45–55.
<http://www.environmentalforensics.org/journal.htm>.
- Kulkarni, P.S., Crespo, J.G, and Afonso, C.A.M., 2008, Dioxins sources and current remediation technologies — A review: *Environment International* 34 (2008), p139–153.
- Ramsey, C. and A. Hewitt, 2005. A Methodology for Assessing Sample Representativeness, *Environmental Forensics* 6:71-75.
<http://www.environmentalforensics.org/journal/volume6/number2.htm>
- USEPA, 1986, *Scope of Farmer Exemption at 40 CFR §262.10(d) and 262.51*. Memo from Mark Greenwood, Assistant General Counsel, RCRA Branch (LE-132S). U.S. Environmental Protection Agency, May 16, 1986.
[http://yosemite.epa.gov/OSW/rcra.nsf/ea6e50dc6214725285256bf00063269d/B422FD2390EFEE558525670F006BD420/\\$file/11155.pdf](http://yosemite.epa.gov/OSW/rcra.nsf/ea6e50dc6214725285256bf00063269d/B422FD2390EFEE558525670F006BD420/$file/11155.pdf).
- USEPA, 2005, Introduction to USEPA Land Disposal Restrictions (40 CFR Part 268): .S. Environmental Protection Agency, Solid Waste and Emergency Response, September 2005, EPA530-K-05-013, <http://www.epa.gov/wastes/inforesources/pubs/hotline/rmods.htm>.
- USEPA, 2006, *Code of Federal Regulations, Title 40, Part 262*. U.S. Environmental Protection Agency, 2006. <http://www.gpoaccess.gov/ecfr/>.
- USEPA, 2009a, *Draft Recommended Interim Preliminary Remediation Goals for Dioxin in Soil at CERCLA and RCRA Sites (December 2009)*. U.S. Environmental Protection Agency, Office of Superfund Remediation and Technology Innovation, OSWER 9200.3-56, http://epa.gov/superfund/policy/remedy/pdfs/Interim_Soil_Dioxin_PRG_Guidance_12-30-09.pdf.

USEPA, 2009b. *Screening Levels for Chemical Contaminants*. U.S. Environmental Protection Agency, prepared by Oak Ridge National Laboratories, December 2009. <http://epa-prgs.ornl.gov/chemicals/index.shtml>.

USEPA, 2010, *USEPA's Reanalysis of Key Issues Related to Dioxin Toxicity and Response to NAS Comments* (External Review Draft): U.S. Environmental Protection Agency, Washington, DC, EPA/600/R-10/038A, 2010, http://cfpub.epa.gov/ncea/iris_drafts/recordisplay.cfm?deid=222203.

Washington DOE, 2007a, *Relative Bioavailability Estimates for Dioxins/Furans in Soils*. Washington State Department of Ecology, Science Advisory Board Issue Paper on Bioavailability, March 2007. http://www.ecy.wa.gov/programs/tcp/SAB/SAB_mtg_info/Mtg_070319/SAB%20Issue%20Paper%20Bioavailability_March%20'07_JWW%20+%20PK%20+%20CRM.pdf.

Washington DOE, 2007b, *Model Toxics Control Act Statute and Regulation (revised November 2007)*. Washington State Department of Ecology Toxics Cleanup Program, Publication No.94-06, <http://www.ecy.wa.gov/biblio/9406.html>.

WHO, 1998, *Assessment of the Health Risk of Dioxins: A Re-evaluation of the Tolerable Daily Intake (TDI), Consultation (May 1998)*. World Health Organization, Geneva,. <http://www.who.int/pes/docs/dioxin-exec-sum/exe-sumfinal>.

WHO, 2001, *Safety Evaluation of Certain Food Additives and Contaminants (PCDDs, PCDFs, PCBs)*. World Health Organization, Food Additive Series 48, 177p, <http://www.inchem.org/documents/jecfa/jecmono/v48je20.htm>.

WHO, 2002, *Safety Evaluation of Certain Food Additives and Contaminants*. WHO Technical Report Series, Fifty-seventh report of the Joint FAO/WHO Expert Committee on Food Additives, WHO Technical Report Series 909, http://whqlibdoc.who.int/trs/WHO_TRS_909.pdf.

Table 1. Summary of TEQ Dioxin Soil Action Levels and associated soil management categories.

Soil Management Category	Action
Category A (≤ 20 ng/kg)	Background. Within range of expected background conditions in non-agricultural and non-industrial areas. No further action required and no restrictions on land use.
Category B (>20 but ≤ 240 ng/kg)	Minimally Impacted. Exceeds expected background conditions but within range anticipated for agricultural fields. Potential health risks considered to be insignificant. Include Category B soil in remedial actions for more heavily contaminated spill areas as practicable in order to reduce exposure (e.g., outer margins of pesticide mixing areas). Offsite reuse of soil for fill material or as final cover on a decommissioned landfill is acceptable, pending agreement by the landfill and barring hazardous waste restrictions. For existing homes, consider measures to reduce daily exposure to soil (e.g., maintain lawn cover, ensure good hygiene, thoroughly wash homegrown produce, etc.). For new developments on large, former field areas, notify future homeowners of elevated levels of dioxin on the property (e.g., include in information provided to home buyers during property transactions).
Category C (>240 but $\leq 1,500$ ng/kg)	Moderately Impacted. Typical of incinerator ash, burn pits, wood treatment operations that used pentachlorophenol (PCP), and the margins of heavily impacted, pesticide mixing areas associated with former sugarcane operations that used PCP. Restriction to commercial/industrial land use required with a formal restriction to the deed against sensitive land uses (e.g., residential, schools, day care, medical facilities, etc.) in the absence of significant institutional and engineered controls and HDOH approval. Use of soil as soil as intermediate (e.g., temporarily inactive portions) or interim (e.g., daily or weekly) cover at a regulated landfill is acceptable, pending agreement by the landfill and barring hazardous waste restrictions. Preparation of a site-specific, <i>Environmental Hazard Management Plan</i> (EHMP) required if soil left on site for long-term management. Removal of isolated spill areas recommended when practicable in order to minimize future management and liability concerns. This includes controls to ensure no off-site dispersion (e.g., dust or surface runoff) or inadvertent excavation and reuse at properties with sensitive land uses.
Category D ($>1,500$ ng/kg)	Heavily Impacted. Typical of former pesticide mixing areas that used PCP (e.g., sugarcane operations). Remedial actions required under any land use scenario in order to reduce potential exposure. Potentially adverse health risks under both sensitive and commercial/industrial land use scenarios in the absence of significant institutional and/or engineered controls. Disposal of soil at a regulated landfill is acceptable, pending agreement by the landfill and barring hazardous waste restrictions.

ATTACHMENT 1

SUPPLEMENTAL INFORMATION ON DEVELOPMENT AND JUSTIFICATION OF UPDATED TEQ DIOXIN ACTION LEVELS

1.0 Background Information on Dioxins

Dioxins are a group of chlorinated organic molecules whose specific members, referred to as “congeners,” share similar chemical structures and mechanisms of toxicity (WHO 2001, 2002, 2006). Potential sources of dioxins in Hawai‘i include deposition of airborne dioxins originating from off-site sources, application of dioxin-bearing pesticides to agricultural fields, spills of concentrated dioxin-bearing pesticides (e.g., at pesticide mixing areas) and combustion of organic materials in the presence of chlorine (e.g., incinerators, burn pits, fire training pits, building fires, forest fires, etc.). In agricultural areas, the primary source of dioxins in soils is believed to be associated with manufacturing impurities in certain chlorinated pesticides, such as 2,4,5-T and, in particular, pentachlorophenol. Data on the concentration of dioxins in soils outside of agricultural areas are limited. HEER is currently conducting research to collect additional soil data in various types of settings throughout the state.

The risk to human health posed by exposure to dioxins is evaluated based on 17 specific dioxin congeners: 7 polychlorinated dibenzo-*p*-dioxins (PCDDs) and 10 polychlorinated dibenzofurans (PCDFs). The majority of the published literature on dioxin toxicity is limited to 2,3,7,8-Tetrachlorodibenzo-*p*-dioxin (TCDD, USEPA 2010), considered to be the most toxic of the 17 congeners studied. The World Health Organization (WHO) assigns toxicity values, referred to as “Toxicity Equivalence Factors (TEFs),” to specific congeners relative to the toxicity of TCDD (WHO 2006). The reported concentration of each congener in a sample is multiplied by its respective TEF to calculate a “Toxicity Equivalent (TEQ)” concentration. The TEQ concentrations for individual congeners are then added together to obtain a total TEQ concentration for the sample. The U.S. Environmental Protection Agency (USEPA) and HEER office recommend the use of WHO’s TEFs to calculate TEQ dioxin levels for use in human health risk assessments or for comparison to risk-based action levels (USEPA 2009a, HDOH 2009a).

2.0 2008 HEER Dioxin Guidance

Soil action levels published by the HEER office in 2006 and 2008 were based on potential excess cancer risk posed by long-term, direct exposure to dioxins in soil (HDOH 2008a,b). Noncancer health risks were not specifically considered but were presumed to be less significant than cancer risks. The soil action levels were based on the USEPA Regional Screening Levels (RSLs; USEPA 2009b), adjusted to a target excess cancer risk of 10^{-4} (i.e., one in ten thousand; see Attachment 2). Action levels based on a more conservative cancer slope factor published by the Minnesota Department of Health were also developed.

Cancer slope factors published by USEPA and other agencies for dioxins are not fully accepted by the toxicology community and considered by others to be excessively conservative (e.g., Cole

et. al 2003, Hayes and Aylward 2003, NAS 2006). Confidence in the slope factors is considered to be low (see Section 4.4). A target excess cancer risk of 10^{-4} was therefore deemed appropriate (refer to Attachment 2).

The 2008 HEER action levels were used to define three categories of soil each for unrestricted (e.g., “residential”) and commercial/industrial land use scenarios. Specific guidance was then presented for the management of soil in each category. The final action levels and soil categories were defined as follows:

2008 HEER TEQ Dioxin Soil Categories		
Category	Unrestricted/Residential Land Use ¹	Commercial/Industrial Land Use
Category 1 ²	<42 ng/kg	<170 ng/kg
Category 2 ³	42 to ≤450 ng/kg	170 to ≤1,800 ng/kg
Category 3 ³	>450 ng/kg	>1,800 ng/kg

Notes:

1. Includes schools, day care centers, medical facilities and other related sensitive land uses.
2. Action levels based on Minnesota Department of Health cancer slope factors.
3. Action levels based on California EPA cancer slope factors.

No further action was recommended for Category 1 soils under the noted land use. Efforts to minimize exposure (e.g., lawn maintenance) were recommended for Category 2 soils if the soil was associated with widespread, trace-level dioxin contamination in former agricultural fields. Removal or capping of small isolated “hot spots” of Category 2 soils to surrounding, background levels was recommended when feasible in order to minimize exposure, but not considered necessary from a purely health-risk standpoint. Removal or capping of Category 3 soils was recommended. Long-term management of soil at commercial/industrial sites that exceeded the upper action level for unrestricted/residential land use of 450 ng/kg TEQ dioxins was recommended to ensure that the soil was not inappropriately excavated and reused offsite in the future.

3.0 Basis of 2010 Updates to Dioxin Soil Action Levels

This technical memorandum updates the 2008 soil action levels for TEQ dioxin to take into account World Health Organization (WHO) Permissible Tolerable Intake factors for potential cancer and noncancer health risks. Exposure assumptions and model parameters used to develop the earlier action levels are otherwise identical. HDOH considers the WHO factors to be more defensible (e.g., lowest uncertainty factor) and appropriate for use in Hawai‘i in comparison to alternative factors, including cancer slope factors published by USEPA and other agencies, as well as noncancer toxicity factors published by the US Agency for Toxic Substances and Disease Registry (ATSDR) and more recently by USEPA.

A discussion of alternative toxicity factors is provided for comparison. The final, updated soil action levels fall within the range of action levels that could be developed by use of the alternative toxicity factors. A detailed discussion of model equations and assumptions used to generate the action levels is provided in Attachment 2.

3.1 Use of WHO PMTI Factors to Develop Soil Action Levels

This update incorporates the use of WHO Permissible Tolerable Monthly Intake (PTMI) factors (WHO 2001, 2002) to develop alternative soil action levels for TEQ dioxins. The WHO PTMI is intended to limit the long-term, body burden of TEQ dioxins to levels that are not believed to be associated with significant cancer or noncancer health risks. WHO concluded that body burden is a more appropriate measure of potential health risks than is a traditional approach based on daily dose, although the two parameters are closely related.

In 1998 WHO published a Tolerable *Daily* Intake (TDI) range for bioavailable TEQ dioxins of 1 to 4 picograms per kilogram of body weight per day (1-4 pg/kg-day; WHO 1998). The ATSDR published an identical range of TEQ dioxin “Minimal Risk Levels” in the same year (ATSDR 1998, 2008). WHO subsequently published an updated, Permissible *Monthly* Tolerable Intake (PTMI) factor range for TEQ Dioxins of 40 to 100 pg/kg-month, after further review of available studies (WHO 2001, 2002). The PTMI of 100 pg/kg-month is based on a No Observed Effects Level (NOEL, power model) for an equivalent human monthly intake (EHMI) of 330 pg/kg per month, adjusted by safety factor of 3.2 to account for inter-individual differences in toxicokinetics among humans (rounded downward to a value of 100). The PTMI of 40 pg/kg-month is based on a Lowest Observed Effects Level (LOEL, linear model) for an equivalent human monthly intake (EHMI) of 423 pg/kg per month, adjusted by safety factor of approximately 9.6 to account for both use of a LOEL (vs NOEL) and inter-individual differences in toxicokinetics (rounded downward to a value of 40).

The WHO PTMI levels were divided by a factor of 30.4 days/month in order to generate an equivalent, tolerable *daily* intake range of 1.3 pg/kg-day to 3.3 pg/kg-day and allow their use in risk-based models for development soil action levels (see Attachment 2). WHO presents monthly, rather than daily, intake ranges to emphasize that the PMTI range is applicable to long-term exposure only, and is well below levels that could pose immediate health effects. As stated in the WHO document:

“The PTMI is not a limit of toxicity and does not represent a boundary between safe intake and intake associated with a significant increase in body burden or risk. Long-term intakes slightly above the (upper range of the) PTMI would not necessarily result in adverse health effects but would erode the safety factor built into the calculations of the PTMI.”

The more rigorous, NOEL-based PMTI of 100 pg/kg-month (3.3 pg/kg-day) was selected for calculation of final dioxin soil action levels. The adjusted factor was incorporated into the USEPA Regional Screening Level (RSL) models for noncancer health risks. This generated a soil action level 240 ng/kg for unrestricted (e.g., residential) land use and 2,800 ng/kg for commercial/industrial land use (see Attachment 2). The calculated action level for unrestricted land use was retained for use in this guidance (refer to Sections 2 and 3 in main text). As discussed in the following section, the commercial/industrial action level was reduced by a factor of 1.9 to 1,500 ng/kg in order to limit theoretical exposure to dioxins in soil to approximately

50% of the estimated dietary intake for adults (refer also to Attachment 2). The HEER office believes that the final soil action levels are appropriate and practicable for screening of dioxin-contaminated sites in Hawai'i.

Note that the WHO PTMI assumes a 50% bioavailability of TEQ dioxins in food (see footnote to Table 14, WHO 2002). This is similar to estimates of average dioxin bioavailability in soil, as recently reviewed by the Washington Department of the Environment (Washington DOE 2007a,b). In the absence of site-specific data, further adjustment of the WHO PTMI and soil action levels presented in the main text of this guidance based on assumed dioxin bioavailability in soil is not recommended.

3.2 Comparison of Dietary Exposure

A comparison of WHO PTMI factors to typical dietary exposure to TEQ dioxins is useful in order to put potential exposure to dioxins in soil at the action levels noted in perspective. The WHO estimates the mean, dietary intake of TEQ dioxins to be 15 to 160 pg/kg-month at the 90th percentile of mean lifetime exposure (WHO 2002). This equates to a daily dietary exposure of 0.5 to 5 pg/kg-day, or up to 75 pg/day for a 15 kg child and 350 pg/day for a 70 kg adult (default body weights typically used in human health risk assessments).

As summarized in Attachment 3, dietary intake of TEQ dioxins for Pacific-Asian diets heavy in fish and vegetables is estimated to range from 66 pg/day for children (4.4 pg/kg-day for a 15 kg child) and to 102 pg/day adults (1.5 pg/kg-day for a 70 kg adult), respectively. Food of animal origin is estimated to contribute to approximately 80% of overall human exposure to dioxins (USEPA 2010). Other studies have indicated a minimal contribution of TEQ dioxins from soil with respect to dietary intake (e.g., Kimbrough et al 2010).

For comparison, the HDOH soil action level for unrestricted (e.g., residential) land use of 240 ng/kg equates to a theoretical, TEQ dioxin average daily dose of approximately 23 pg/day for a 15 kg child and 12 pg/day for a 70 kg adult (assuming a soil ingestion rate of 200 mg/day for children and 100 mg/day for adults, a bioavailability of 50% and the additional exposure factors noted in Attachment 2). This represents approximately 35% of the estimated dietary exposure for a 15 kg child (USEPA default body weight for children, as averaged for ages 1-6; refer to Attachment 2).

The HDOH soil action level for commercial/industrial land use of 2,800 ng/kg equates to a theoretical, TEQ dioxin average daily dose of approximately 96 pg/day for a 70 kg adult. This is approximately equal to the estimated dietary exposure of adults to TEQ dioxins. As an added measure of safety, however, HEER decided to reduce the soil action level to 1,500 ng/kg in order to limit the theoretical exposure to dioxins in soil to 50 pg/day or approximately 50% of the estimated dietary exposure (added safety factor of 1.9; refer to Attachment 2). Actual exposure to dioxins in soil for both children and adults is likely to be much lower than exposure predicted by the models due to the conservative nature of the exposure factors assumed in the models.

3.3 Comparison to 2009 USEPA RSLs Adjusted for Relative Bioavailability

The 2009 USEPA Regional Screening Levels (RSLs; USEPA 2009b) do not consider the relative bioavailability of dioxins in soil (i.e., relative bioavailability of dioxins in soil in comparison to bioavailability of dioxins in laboratory-based studies). Guidance published by the Washington Department of Ecology (DOE) was used to adjust the USEPA RSLs for comparison to WHO-based action levels (Washington DOE 2007a,b; see Attachment 2). Washington DOE presents the following rationale for use of a gastrointestinal absorption adjustment (bioavailability) factor in the calculation of soil screening levels for cancer risk concerns:

- Available evidence suggests that soil-bound dioxins/furans are less bioavailable than dioxins/furans used to assess the health risks from bioassays, epidemiological studies or studies used to assess the toxicity of dioxins/furans in foods and drinking water.
- Although there is uncertainty in assigning congener-specific bioavailability estimates, the available evidence suggests that the higher-chlorinated dioxin/furan congeners (hexa-, hepta-, octa-) are less well absorbed and less bioavailable than the lower-chlorinated congeners (tetra- and penta-).
- Within a range of uncertainty and variability, available evidence suggests that congener-specific differences in bioavailability should be considered when evaluating the toxicity and assessing the risks for mixtures of dioxins/furans.

Based on a review of published studies, Washington DOE (2007a) recommended a default relative bioavailability 0.7 for the tetra- and penta-chlorinated dioxin/furan congeners, and 0.4 for the less available (but usually more abundant) hexa-, hepta-, and octa-chlorinated congeners (i.e., bioavailability in soil *relative* to the bioavailability in the food used in the animal studies, estimated to be between 80% and 90%; USEPA 2010). Final guidance published by Washington DOE recommended a weighted, relative bioavailability or gastrointestinal absorption fraction for TEQ dioxins of 0.6, based on typical mixtures of dioxin/furan congeners identified in soil (Washington DOE 2007b). This was consistent with the default, relative bioavailability of TEQ dioxins in soil recommended by a majority of other State and international agency guidance reviewed by Washington DOE. Assuming a bioavailability of dioxins in the food used in animal studies of 80% to 90%, this equates to an ultimate bioavailability of dioxins in soil of approximately 50%, similar to the bioavailability of dioxins assumed in the WHO PMTI factors (refer to Section 3.1).

An internal HEER review of dioxin/furan congener soil data from former sugarcane operations in Hawai'i indicated an average mixture of 2% tetra- and penta- dioxin/furan congeners and 98% hexa-, hepta-, and octa- congeners, with a worst-case instance of 20% tetra- and penta-dioxin/furan congeners and 80% hexa-, hepta-, and octa- congeners. Applying Washington DOE's approach to dioxin data from former sugarcane fields and pesticide mixing area in Hawai'i, HEER calculated TEQ dioxin bioavailability factors from 0.41 (average) to 0.46

(worst-case). This suggests that the default, relative bioavailability of 0.6 published by the Washington DOE is adequately for modification of the USEPA RSLs.

Modification of the 2009 USEPA RSLs for relative bioavailability applies only to the incidental ingestion portion of the soil action level models. As indicated in Attachment 2, a separate absorption factor is used for dermal exposure. Relative bioavailability is not considered for inhalation of particulates. The latter two exposure pathways are relatively minor in comparison to incidental ingestion. Adjustment of the incidental ingestion portion of the soil model to reflect a relative bioavailability 0.6 and use of a target, excess cancer risk of 10^{-4} yields modified RSLs of 650 ng/kg and 2,400 ng/kg for unrestricted/residential land use and commercial/industrial land use respectively.

The updated TEQ dioxin soil action level for unrestricted land use presented in the main text (240 ng/kg) is more conservative than the USEPA RSL adjusted for relative bioavailability and a target excess cancer risk of 10^{-4} . The updated action level for commercial/industrial land use (1,500 ng/kg) is also lower than the adjusted RSL.

3.4 Comparison to 2009 USEPA TEQ Dioxin PRGs (Draft)

USEPA recently published a draft document entitled *Recommended Interim Preliminary Remediation Goals (PRGs) for Dioxin in Soil at CERCLA and RCRA Sites* (USEPA 2009a). Although the final PRGs are similar to the updated HDOH soil action levels presented above, the HEER office considers the approach presented in this technical memorandum to be more applicable for use in Hawai'i.

The USEPA draft guidance proposes to retract screening levels for TEQ dioxins published in 1998 for use at CERCLA and RCRA sites, including the often cited screening levels of 1 $\mu\text{g}/\text{kg}$ TEQ dioxins for residential soils and 5 to 20 $\mu\text{g}/\text{kg}$ for commercial/industrial soils (USEPA 1998). The HEER office had previously discounted use of these action levels in Hawai'i, after concluding that they may not be adequately protective of human health in some circumstances.

As an alternative, the draft USEPA document proposes use of the 1998 ATSDR Minimal Risk Level (MRL) to develop TEQ dioxin soil screening levels or "Preliminary Remediation Goals" ("PRGs"). The ATSDR document presents an MRL range for TEQ dioxins of 1 to 4 pg per kilogram bodyweight per day (pg/kg-day), identical to guidance published by the World Health Organization the same year (see above). This equates to an exposure of 15 to 60 pg/day for a 15 kg child (average child bodyweight used in noncancer risk assessments) or 60 to 280 pg/day TEQ dioxins for a 70kg adult (lifetime average bodyweight used in cancer risk assessments). Exposures below these levels are assumed to not pose a significant health risk. Note that the upper limit of the ATSDR MRL range is slightly less conservative than the range proposed by WHO (WHO 2002; see above).

Using the models and exposure assumptions presented in the draft guidance with the ATSDR MRL range for TEQ dioxins of 1 to 4 pg/kg-day yields a soil screening level range of 72 to 290 ng/kg for residential land use and 850 to 3,400 ng/kg for commercial/industrial land use. This is

comparable to the range of screening levels generated by use of the WHO PTMI guidance as described above and in the main text of this document. The draft USEPA document proposed a TEQ dioxin “Preliminary Remediation Goal” (PRG) of 72 ng/kg for residential soil and 950 ng/kg for commercial/industrial, based on use of the low end of the ATSDR MRL range, or 1 pg/kg-day. These action levels do not consider the relative bioavailability of dioxins in soil (see Section 3.2). Adjusting for a relative bioavailability of 0.6 would yield correlative PRGs of 120 ng/kg and 1,600 ng/kg, respectively. While the HEER office does not disagree that soils with concentrations of TEQ dioxins below the proposed PRGs levels do not pose a significant health risk, HEER feels that the PRGs are too conservative to be useful for initial screening purposes in Hawai‘i. As discussed above, the HEER office also prefers use of the more recent, WHO PTMI guidance over the 1998 ATSDR guidance.

The draft USEPA document also notes that the proposed PRGs fall within the range of screening levels that would be generated using cancer slope factors published by the USEPA in the 1980s and a risk range of 10^{-6} to 10^{-4} (e.g., 4.5 to 450 ng/kg for residential soil and 18 to 1,800 ng/kg; based on the current USEPA RSLs; USEPA 2009b). Note that identical, noncancer screening levels for TEQ dioxins were calculated as part of the 2009 USEPA RSL guidance but ultimately not selected as the final RSLs, since the screening level for cancer concerns assumes a target risk of 10^{-6} .

As discussed below, HEER prefers to focus on remediation of *localized* areas of dioxin-contaminated soil (e.g., pesticide mixing areas) to meet the surrounding area background concentrations *as practicable* on a site-by-site basis, rather than deferring to a purely risk-based soil action level. Remediation of minimally impacted soils in large, former agricultural fields to natural background concentrations (e.g., <20 ng/kg) is considered to be impracticable and, from the standpoint of risk and added health benefit, unnecessary. This is supported by consideration of dietary intake of dioxins and furans, which is estimated to exceed the hypothetical intake associated with long-term exposure to soils with concentrations of TEQ dioxins at or below the updated action levels.

3.5 Comparison to 2010 USEPA TCDD Toxicity Review (Draft)

USEPA recently released a draft review of published literature on the health effects of tetrachlordibenzenedioxin (TCDD) and related compounds (USEPA 2010). USEPA focused on two studies of human exposure to TCDD to develop a draft, noncancer reference dose. A Lowest Observed Adverse Effects Level (LOAEL) of 20 pg/kg-day exposure to TCDD was ultimately selected for development of an oral reference dose (RfD).

The selected LOAEL of 20 pg/kg-day is well above the WHO Permissible Tolerable Intake of 3.3 pg/kg-day used to develop soil action levels in this technical memorandum (refer to Section 3.2). In the draft document, however, USEPA reduces the LOAEL by an uncertainty factor of ten due to the lack of a No Observed Adverse Effects Level (NOAEL) for TCDD. The LOAEL is further reduced by a factor of three to account for human inter-individual variability, for a total uncertainty factor of thirty. The document then proposes a final, draft, TCDD reference dose of 0.7 pg/kg-day.

The selected WHO tolerable intake factor of 3.3 pg/kg-day exceeds the final RfD of 0.7 pg/kg-day selected by USEPA in its draft document. The WHO factor falls near the low end of the RfD and LOAEL low-risk range of TCDD exposure identified in the draft review, however (0.70 pg/kg-day to 20 pg/kg-day). Adjustment of the draft USEPA RfD to take into account a reduced relative bioavailability of dioxins in soil would further reduce the difference between action levels derived by either method. For example, use of the draft RfD in the USEPA RSL models would yield soil action levels of approximately 50 ng/kg and 600 ng/kg for residential and commercial/industrial land use, respectively (refer to Attachment 2). Adjustment for a relative bioavailability of dioxins in soil of 0.6 (see Section 3.2) yields action levels of 85 ng/kg and 1,000 ng/kg, respectively.

The draft USEPA document also presents an oral slope factor range of 1.1×10^5 (mg/kg-day)⁻¹ to 1.6×10^6 (mg/kg-day)⁻¹ for possible use in cancer risk assessments, depending on the selected target risk. As discussed above, the 2009 USEPA RSLs for 2,3,7,8 dioxins is based on a slope factor of 1.3×10^5 (mg/kg-day)⁻¹. Use of a more conservative slope factor would (e.g., 7.8×10^5 (mg/kg-day)⁻¹ based on target risk of 10^{-4}) would reduce the RSL by a factor of approximately six. As discussed above, the cancer slope factors incorporate a relatively high degree of uncertainty and confidence in their use to develop meaningful soil action levels is low.

HDOH does not feel that use of an RfD or cancer slope factor that equates to an exposure below anticipated dietary intake to derive soil action levels is practical. At this time, and in consideration of the multiple lines of evidence summarized in Section 2 of the main text, HDOH considers the WHO PTMI factors to be the most technically supportable and appropriate values for development of direct-exposure soil action levels for use in Hawai'i.

References:

ATSDR 1998. *Toxicological Profile for Chlorinated Dibenzo-p-dioxins (CDDs)*. Agency for Toxic Substances and Disease Registry, December 1998.
<http://www.atsdr.cdc.gov/toxprofiles/tp104.html>.

ATSDR 2008. *Update to the ATSDR Policy Guideline for Dioxins and Dioxin-Like Compounds in Residential Soil*. Agency for Toxic Substances and Disease Registry, November 2008.
<http://www.atsdr.cdc.gov/substances/dioxin/policy/>.

Cole, P., Trichopoulos, Pastides, H., Starr, T and J.S. Mandel, 2003, Dioxin and cancer: a critical review: *Regulatory Toxicology and Pharmacology*, Vol. 38, p.378–388.

Hays, S. M. and L.L. Aylward, 2003, Dioxin risks in perspective: past, present, and future: *Regulatory Toxicology and Pharmacology*, Vol. 37, p. 202–217.

HDOH 2008a. *Tier 2 Action Levels for TEQ dioxins (update to March 23, 2006 memorandum)*. Hawai'i Department of Health, Hazard Evaluation and Emergency Response Office.

HDOH 2008b. *Evaluation of Environmental Hazards at Sites with Contaminated Soil and Groundwater (Summer 2008, updated March 2009)*. Hawai'i Department of Health, Hazard Evaluation and Emergency Response Office, March 2009.

<http://www.hawaii.gov/health/environmental/hazard/eal2005.html>.

HDOH 2009. *Technical Guidance Manual for the Implementation of the Hawai'i State Contingency Plan*. Hawai'i Department of Health, Hazard Evaluation and Emergency Response Office, <http://www.hawaiidoh.org>.

Kimbrough, R.D., Krouskas C.A., Carson M.L., Long T.F., Bevan C. and R.G., Human uptake of persistent chemicals from contaminated soil: PCDD/Fs and PCBs, *Regulatory Toxicology and Pharmacology*, 2010 June, 57(1), p.43-54.

NAS, 2006, *Health Risks from Dioxin and Related Compounds: Evaluation of the EPA Reassessment*: National Academy of Sciences, Committee on EPA's Exposure and Human Health Reassessment of TCDD and Related Compounds ISBN: 978-0-309-10259-9, 268p, <http://www.nationalacademies.org/morenews/20060711c.html>.

USEPA 1998. *Approach for Addressing Dioxin in Soil at CERCLA and RCRA Sites*. Memo from Timothy Fields, EPA Acting Administrator, to Regional Directors, U.S. Environmental Protection Agency Office of Solid Waste and Emergency Response, OSWER Directive 9200.4-26, April 13, 1998. <http://www.epa.gov/superfund/resources/remedy/pdf/92-00426-s.pdf>.

USEPA 2009a. *Draft Recommended Interim Preliminary Remediation Goals for Dioxin in Soil at CERCLA and RCRA Sites (December 2009)*. U.S. Environmental Protection Agency, Office of Superfund Remediation and Technology Innovation, OSWER 9200.3-56, http://epa.gov/superfund/policy/remedy/pdfs/Interim_Soil_Dioxin_PRG_Guidance_12-30-09.pdf.

USEPA 2009b. *Screening Levels for Chemical Contaminants*. U.S. Environmental Protection Agency, prepared by Oak Ridge National Laboratories, December 2009. <http://epa-prgs.ornl.gov/chemicals/index.shtml>.

USEPA, 2010, *USEPA's Reanalysis of Key Issues Related to Dioxin Toxicity and Response to NAS Comments (External Review Draft)*: U.S. Environmental Protection Agency, Washington, DC, EPA/600/R-10/038A, 2010, http://cfpub.epa.gov/ncea/iris_drafts/recordisplay.cfm?deid=222203.

Washington DOE 2007a. *Relative Bioavailability Estimates for Dioxins/Furans in Soils*. Washington State Department of Ecology, Science Advisory Board Issue Paper on Bioavailability, March 2007.

http://www.ecy.wa.gov/programs/tcp/SAB/SAB_mtg_info/Mtg_070319/SAB%20Issue%20Paper%20Bioavailability_March%20'07_JWW%20+%20PK%20+%20CRM.pdf.

Washington DOE 2007b. *Model Toxics Control Act Statute and Regulation (revised November 2007)*. Washington State Department of Ecology Toxics Cleanup Program, Publication No.94-06, <http://www.ecy.wa.gov/biblio/9406.html>.

WHO 1998. *Assessment of the Health Risk of Dioxins: A Re-evaluation of the Tolerable Daily Intake (TDI), Consultation (May 1998)*. World Health Organization, Geneva,. <http://www.who.int/pcs/docs/dioxin-exec-sum/exe-sumfinal>.

WHO 2001. *Safety Evaluation of Certain Food Additives and Contaminants (PCDDs, PCDFs, PCBs)*. World Health Organization, Food Additive Series 48, 177p, <http://www.inchem.org/documents/jecfa/jecmono/v48je20.htm>.

WHO 2002. *Safety Evaluation of Certain Food Additives and Contaminants*. WHO Technical Report Series, Fifty-seventh report of the Joint FAO/WHO Expert Committee on Food Additives, WHO Technical Report Series 909, http://whqlibdoc.who.int/trs/WHO_TRS_909.pdf.

WHO 2006. *The 2005 World Health Organization Re-evaluation of Human and Mammalian Toxic Equivalency Factors for Dioxins and Dioxin-like Compounds (van den Berg, M., et al.)*. World Health Organization, July 7, 2006. http://www.who.int/ipcs/assessment/tef_update/en/.

ATTACHMENT 2

EQUATIONS AND ASSUMPTIONS FOR DERIVATION OF TEQ DIOXIN SOIL ACTION LEVELS

1.0 Introduction

A summary of models and assumptions used to develop for human health, direct-exposure concerns is presented below. For addition information on the models, refer to the USEPA document *Screening Levels for Chemical Contaminants* (USEPA 2009). See also Appendix 1 of the HEER *EHE Guidance* (HDOH 2008b).

2.0 TEQ Dioxin Toxicity Factors and Bioavailability

The WHO Permissible Tolerable Monthly Intake (PTMI) upper limit of 100 pg/(kg-month) is used to calculate noncancer soil action levels (WHO 2002). The PTMI is converted to a Permissible Tolerable *Daily* Intake (PTDI) level of 3.3 pg/(kg-day) for use in the noncancer equations. Although not necessarily applicable, a default Hazard Quotient of 1.0 is also assumed in the equations. A Cancer Slope Factor (CSF) of $1.3E+05$ (mg/kg-day)⁻¹ and an Inhalation Unit Risk Factor (IURF) of 38 (μg/m³)⁻¹ were selected for calculation of cancer-based soil action levels (USEPA 2009; CSF adopted from CalEPA). Action levels are based on a target excess cancer risk of 10^{-4} .

The equations incorporate an additional Gastrointestinal Absorption Factor (GIABS) to adjust for the bioavailability of dioxins and furans in soil, as necessary. A default GIABS for dioxins and furans of 0.6 is assumed for soils (Washington DOE 2007a,b). This is used to adjust the incidental ingestion exposure portion of the cancer-based action level (see Table 1 and Equations 1 and 3). An assumed bioavailability of 0.5 is directly incorporated into the WHO PTMI; further adjustment of bioavailability for exposure to soil is therefore not warranted (GIABS_{nc} = 1; see Table 1 and Equations 2 and 4).

3.0 Soil Action Levels Models

Human exposure assumptions are summarized in Table 1. With the exceptions noted, parameter values in Table 1 were taken directly from the USEPA Regional Screening Level (RSL) guidance document (USEPA 2009). Parameter values for the construction/trench worker exposure scenario are discussed in more detail in Appendix 1. Tables 2 and 3 summarize equations and parameter values used to develop the RSL Particulate Emission Factor and physiochemical constants assumed in the models for TEQ dioxins.

Carcinogenic risks under unrestricted/residential exposure scenarios were calculated using the following age-adjusted factors. Definition of terms and default parameter values used in the equations are presented in Tables 1, 2, and 3.

1) Ingestion [(mg·yr)/kg·d]:

$$IFS_{adj} = \frac{ED_c \times IRS_c}{BW_c} + \frac{(ED_r - ED_c) \times IRS_a}{BW_a}$$

2) Dermal Contact [(mg·yr)/kg·d]:

$$SFS_{adj} = \frac{ED_c \times AF_c \times SA_c}{BW_c} + \frac{(ED_r - ED_c) \times AF_a \times IRS_a}{BW_a}$$

3) Inhalation [(m³·yr)/kg·d]:

$$InhF_{adj} = \frac{ED_c \times IRA_c}{BW_c} + \frac{(ED_r - ED_c) \times IRA_a}{BW_a}$$

Direct exposure equations for soil are summarized as follows:

Equation 1: Combined Exposures to Carcinogenic Contaminants in Residential Soil

$$C(\text{mg/kg}) = \frac{TR \times AT_c}{EF_r \left[\left(\frac{IFS_{adj} \times GIABSc \times CSF_o}{10^6 \text{ mg/kg}} \right) + \left(\frac{SF_{adj} \times ABS \times CSF_o}{10^6 \text{ mg/kg}} \right) + \left(\frac{InhF_{adj} \times CSF_i}{PEF} \right) \right]}$$

Equation 2: Combined Exposures to Noncarcinogenic Contaminants in Residential Soil

$$C(\text{mg/kg}) = \frac{THQ \times BW_c \times AT_n}{EF_r \times ED_c \left[\left(\frac{1}{RfD_o} \times \frac{IRS_c \times GIABSc}{10^6 \text{ mg/kg}} \right) + \left(\frac{1}{RfD_o} \times \frac{SA_c \times AF_c \times ABS}{10^6 \text{ mg/kg}} \right) + \left(\frac{1}{RfD_i} \times \frac{IRA_c}{PEF} \right) \right]}$$

Equation 3: Combined Exposures to Carcinogenic Contaminants in Industrial Soil

$$C(\text{mg/kg}) = \frac{TR \times BW_a \times AT_c}{EF_o \times ED_o \left[\left(\frac{IRS_o \times GIABSc \times CSF_o}{10^6 \text{ mg/kg}} \right) + \left(\frac{SA_a \times AF_a \times ABS \times CSF_o}{10^6 \text{ mg/kg}} \right) + \left(\frac{IRA_a \times CSF_i}{PEF} \right) \right]}$$

Equation 4: Combined Exposures to Noncarcinogenic Contaminants in Industrial Soil

$$C(\text{mg/kg}) = \frac{THQ \times BW_a \times AT_n}{EF_o \times ED_o \left[\left(\frac{1}{RfD_o} \times \frac{IRS_o \times GIABSc}{10^6 \text{ mg/kg}} \right) + \left(\frac{1}{RfD_o} \times \frac{SA_a \times AF_a \times ABS}{10^6 \text{ mg/kg}} \right) + \left(\frac{1}{RfD_i} \times \frac{IRA_a}{PEF} \right) \right]}$$

Equation 5: Derivation of Particulate Emission Factor (residential & occupational)

$$PEF(m^3/kg) = Q/C \times \frac{3600s/h}{0.036 \times (1-V)(U_m/U_t)^3 \times F(x)}$$

The USEPA RSL models incorporate a Volatilization Factor (VF) for emission of volatile chemicals to outdoor air. Volatile chemicals are defined as having a Henry's Law Constant of $>1.0E-05$ (atm·m³)/mol and a molecular weight of <200 g/mol. Dioxin/furan mixtures do not meet this definition. The VF term in the soil equations is therefore replaced with the Particulate Emission Factor (PEF) term for non-volatile chemicals.

4.0 Calculated Soil Action Levels**4.1 Unadjusted Action Levels**

Based on the models and model assumptions described above and in Table 1, a TEQ dioxin soil action level of 240 ng/kg is generated for unrestricted (e.g., residential) land use. This action level was retained for use in the final guidance (refer to Table 1 in the main text). A preliminary soil action level of 2,800 ng/kg is generated for commercial/industrial land use. As described below, this action level was adjusted by an additional safety factor of 1.9 in order to minimize exposure to dioxins in soil to approximately 50% of the estimated dietary exposure.

4.2 Adjustment of Commercial/Industrial Soil Action Level

The HDOH soil action level for commercial/industrial land use of 2,800 ng/kg equates to a theoretical exposure to TEQ dioxins of approximately 96 pg/day for a 70 kg adult (refer to Section 3.2 in main text). This is approximately equal to the estimated dietary exposure of adults to TEQ dioxins. As an added measure of safety, however, HEER decided to reduce the soil action level to 1,500 ng/kg in order to limit the theoretical exposure to dioxins in soil to 50 pg/day or approximately 50% of the estimated dietary exposure (added safety factor of 1.9). Actual exposure to dioxins in soil for both children and adults is likely to be much lower than exposure predicted by the models due to the conservative nature of the exposure factors assumed in the models.

References

- MADEP, 1994, *Background Documentation for the Development of the MCP Numerical Standards*. Massachusetts Department of Environmental Protection, Bureau of Waste Site Cleanup and Office of Research and Standards, April 1994. <http://www.mass.gov/dep/cleanup/bacdoc.pdf>.
- USEPA, 1974, *Development of Emission Factors for Fugitive Dust Sources*. U.S. Environmental Protection Agency, Publication No. EPA-450/3-74-037, (prepared by Cowherd, C., Axetell, K., Guenther, C., and Jutze, G., Midwest Research Institute). 1974.

Attachment 2: Model Equations and Assumptions

June 2010

Page 4

USEPA, 1985, *Compilation of Air Pollutant Emission Factors, Volume 1: Stationary Point and Area Sources*. U.S. Environmental Protection Agency, Office of Air and Radiation, Publication No. AP-42, Fourth Edition, September 1985. <http://www.epa.gov/ttnchie1/ap42/>.

USEPA, 2000, *User's Guide for the Johnson and Ettinger (1991) Model for Subsurface Vapor Intrusion into Buildings*. U.S. Environmental Protection Agency, Office of Emergency and Remedial Response, September 1997. http://rais.ornl.gov/johnson_ettinger.html.

USEPA, 2002, *Supplemental Guidance for Developing Soil Screening Levels for Superfund Sites*. U.S. Environmental Protection Agency, Solid Waste and Emergency Response, OSWER 9355.4-24, December 2002. <http://www.epa.gov/superfund/health/conmedia/soil/index.htm>.

USEPA, 2009, *Screening Levels for Chemical Contaminants*. U.S. Environmental Protection Agency, December 2009. <http://www.epa.gov/region09/waste/sfund/prg/>.

Washington DOE, 2007a, *Relative Bioavailability Estimates for Dioxins/Furans in Soils*. Washington State Department of Ecology, Science Advisory Board Issue Paper on Bioavailability, March 2007, http://www.ecy.wa.gov/programs/tcp/SAB/SAB_mtg_info/Mtg_070319/SAB%20Issue%20Paper%20Bioavailability_March%20'07_JWW%20+%20PK%20+%20CRM.pdf.

Washington DOE, 2007b, *Model Toxics Control Act Statute and Regulation (revised November 2007)*. Washington State Department of Ecology Toxics Cleanup Program, Publication No.94-06, <http://www.ecy.wa.gov/biblio/9406.html>.

TABLE 1. HUMAN EXPOSURE PARAMETER DEFINITIONS AND DEFAULT VALUES

Symbol	Definition (units)	Value	Units	References (see USEPA 2002 for full references)
CSFo	Cancer slope factor, oral	1.3E+05	(mg/(kg·d)) ⁻¹	USEPA 2009 (references California EPA 2008)
CSFi	Cancer slope factor, inhaled	38	(ug/m ³) ⁻¹	USEPA 2009 (references California EPA 2008)
RfDo	Reference dose, oral	3.3E-09	mg/(kg·d)	WHO 2002, see text
RfDi	Reference dose, inhaled	-	mg/(kg·d)	-
TRr/o	Target cancer risk – residential or occupational exposure scenario	1.0E-04	Unitless	HDOH, see text
THQ	Target hazard quotient	1.0	Unitless	See text
BWa	Body weight, adult	70	Kg	USEPA 2009
BWc	Body weight, child	15	Kg	USEPA 2009
ATc	Average time, cancer risk	25,550	D	USEPA 2009
ATn	Average time, noncancer risk	ED × 365	d	USEPA 2009
SAar	Exposed surface area, adult residential	5.7E+03	cm ² /d	USEPA 2009
SAaw	Exposed surface area, adult occupational	3.3E+03	cm ² /d	USEPA 2009
SAc	Exposed surface area, child	2.8E+03	cm ² /d	USEPA 2009
AFar	Adherence factor, adult residential	0.07	mg/cm ²	USEPA 2009
AFaw	Adherence factor, occupational	0.20	mg/cm ²	USEPA 2009
AFc	Adherence factor, child	0.20	mg/cm ²	USEPA 2009
ABS	Skin absorption, chemical specific	0.03	unitless	USEPA 2009
IRaA	Inhalation rate, adult	20	m ³ /d	USEPA 2009
IRAc	Inhalation rate, child	10	m ³ /d	USEPA 2009
IRSa	Soil ingestion, adult	100	mg/d	USEPA 2009
IRSc	Soil ingestion, child	200	mg/d	USEPA 2009
IRSo	Soil ingestion, occupational	50	mg/d	USEPA 2009
GIABSc	Gastrointestinal Absorption Adjustment Factor, cancer risk	0.6	unitless	Washington DOE 2007b, see text
GIABScnc	Gastrointestinal Absorption Adjustment Factor, noncancer risk	1.0	unitless	No adjustment; 50% dioxin bioavailability assumed in food (WHO 2002), see text
EFr	Exposure frequency, residential	350	d/yr	USEPA 2009
EFo	Exposure frequency, occupational	250	d/yr	USEPA 2009
EDr	Exposure duration, residential	30	yr	USEPA 2009
EDc	Exposure duration, child	6	yr	USEPA 2009
EDo	Exposure duration, occupational	25	yr	USEPA 2009
IFSadj	Ingestion factor, soil	114	(mg·yr)/(kg·d)	USEPA 2009
SFSadj	Skin contact factor, soil	361	(mg·yr)/(kg·d)	USEPA 2009
InhFadj	Inhalation factor	11	(m ³ ·yr)/(kg·d)	USEPA 2009
PEFres/oc	Particulate emission factor, residential/occupational exposure scenarios	1.32E+09	m ³ /kg	USEPA 2009

Primary Reference: USEPA *Screening Levels for Chemical Contaminants* (USEPA 2009).

TABLE 2. PARTICULATE EMISSION FACTOR PARAMETER DEFINITIONS AND DEFAULT VALUES - RESIDENTIAL/OCCUPATIONAL SCENARIOS

Parameter	Definition	Default Value	Units
PEF *	Particulate emission factor	1.316E+09	m ³ /kg
Q/C	Inverse of the mean concentration at the center of a 0.5-acre-square source	90.80	g/(m ² ·s) per kg/m ³
V	Fraction of vegetative cover	0.5	unitless
Um	Mean annual windspeed	4.69	m/s
Ut	Equivalent threshold value of windspeed at 7 m	11.32	m/s
F(x)	Function dependent on Um/Ut derived using Cowherd (1985)	0.194	unitless

* Equivalent to an airborne dust concentration, in mg/m³, of (1,000,000 mg / 1 kg) / PEF = 0.0007 mg/m³.

TABLE 3. DEFAULT PHYSIOCHEMICAL PARAMETERS FOR TEQ DIOXINS (USEPA 2009)

Parameter	Default Value	Units
Molecular weight	3.56E+02	g/mol
Koc	2.57E+05	l/kg
Solubility in water	1.2E-04	mg/l
Henry's Law Constant	2.2E-06	(atm·m ³)/mol
Henry's Law Constant	9.0E-05	unitless

ATTACHMENT 3

**ESTIMATED DIETARY INTAKE
OF TEQ DIOXIN FOR PACIFIC-ASIAN DIETS
(see main text for full references)**

Table 1. Estimated food consumption for a Pacific-Asian diet.

Food Group	Child (Ave 6mo-5yr)		Mean Population		Consumption (kg/day)	
	¹ Consumption (g/d)	Percent of Total	¹ Consumption (g/d)	Percent of Total		
Cereals & Cereal Products	166	32%	364	43%		
Rice & Products	122	23%	303	58%		
Corn and Products	17	3%	31	6%		
Other Cereals and Products	27	5%	30	6%		
Starch Roots and Tubers	8	2%	19	4%		
Sugars and Syrups	15	3%	24	5%		
Fats and Oils	6	1%	18	3%		
Fish, Meat & Poultry	95	18%	185	35%		
Fish and Products	57	11%	104	20%		
Meat and Products	27	5%	61	12%		
Poultry and Products	11	2%	20	4%		
Eggs	8	2%	13	2%		
Milk and Products	179	34%	49	9%		
Whole Milk	158	30%	35	7%		
Milk Products	21	4%	14	3%		
Dried Beans, Nuts & Seeds	4	1%	10	2%		
Vegetables	13	2%	111	21%		
Green Leafy & Yellow	10	2%	31	6%		
Other Vegetables	3	1%	80	15%		
Fruits	31	6%	54	10%		
Vitamin C-rich Fruits	4	1%	12	2%		
Other Fruits	27	5%	42	8%		
Total Food Consumption:	525		847			

Combined Food Groups	Child	Mean
¹ Fuits & Vegetables	0.237	0.582
Dairy	0.179	0.049
² Meat	0.044	0.099
Fish	0.057	0.104
Eggs	0.008	0.013
Total:	0.525	0.847

1. Including cereals and cereal products, starch roots and tubers, dried beans, nuts and seeds.

2. Including fats, oil & poultry.

Reference: FNRI, 2003, The 6th National Nutrition Survey: Food, Philippine Department of Science and Technology, Nutrition and Research Institute,
<http://www.fnri.dost.gov.ph/index.php?option=content&task=view&id=1130>

1. Raw as purchased (rice and cereals presumably dry weight).

Table 2. Estimated dietary intake of TEQ dioxins based on a typical Asian-Pacific diet (see also Table 1).

Food Group	¹ TEQ Dioxins (pg/kg)	⁴ Child (6mo-5yr)			⁵ Mean Population		
		² Daily Dose (pg/d)	^{3,4} Daily Intake (pg/Kg-d)	Percent TEQ Dioxins Contribution	¹ Daily Intake (pg/d)	^{3,5} Daily Dose (pg/Kg-d)	Percent TEQ Dioxins Contribution
Fruits and Vegetables	40	9.5	0.63	14%	23.3	0.33	23%
Dairy	100	17.9	1.19	27%	4.9	0.07	5%
Meat	130	5.7	0.38	9%	12.9	0.18	13%
Fish	560	31.9	2.13	48%	58.2	0.83	57%
Eggs	170	1.4	0.09	2%	2.2	0.03	2%
Total:		66	4.43	100%	102	1.45	100%

1. WHO, 2002, Safety Evaluation of Certain Food Additives and Contaminants: WHO Technical Report Series, Fifty-seventh report of the Joint FAO/WHO Expert Committee on Food Additives, WHO Technical Report Series 909, http://whqlibdoc.who.int/trs/WHO_TRS_909.pdf. Data for North America (vegetable data from Europe).

2. Calculated as: Daily Food Group Consumption (refer to Table 1; converted to kg/day) multiplied by the noted Food Group TEQ Dioxins concentration (converted to pg/kg).

3. Calculated as: Estimated Daily Intake in pg/day divided by assumed weight in Kg.

4. Assumed Child Weight = 15 Kg (default in USEPA risk assessment guidance; e.g., USEPA 2009b).

5. Assumed Mean Population Weight =70 Kg (default in USEPA risk assessment guidance; e.g., USEPA 2009b).

Figure 1. Summary of estimated TEQ dioxin intake based on a Pacific-Asian diet [based on data reported by WHO for dioxin in food (WHO 2002)]

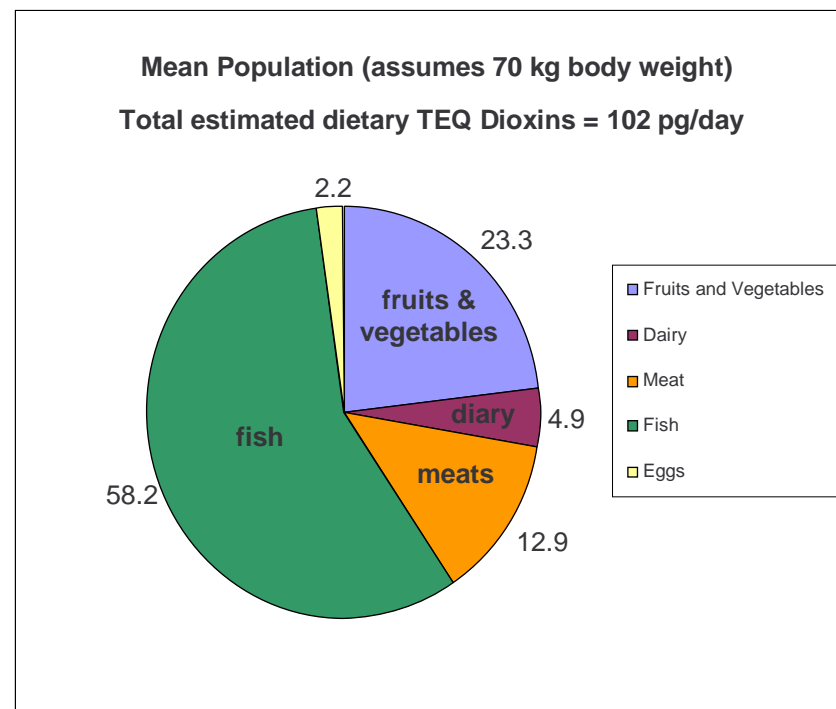
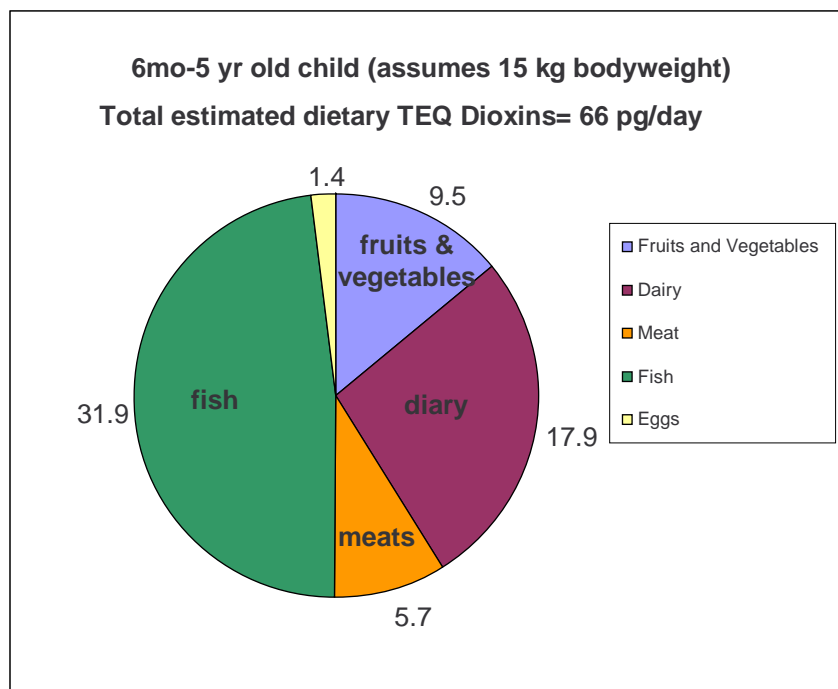

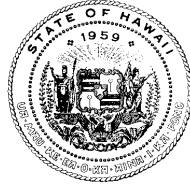

STATE OF HAWAII
DEPARTMENT OF HEALTH
P.O. Box 3378
HONOLULU, HAWAII 96801-3378

In reply, please refer to:
File: EHA/HEER Office

TO: Interested Parties 2007-223-RB

FROM: Roger Brewer, Ph.D
Environmental Risk Assessment
Hazard Evaluation and Emergency Response

THROUGH: Barbara Brooks, Ph.D
Toxicologist
Hazard Evaluation and Emergency Response

DATE: April 12, 2007

SUBJECT: Use of laboratory batch tests to evaluate potential leaching of contaminants from soil (update to November 2006 technical memorandum)

Executive Summary

This technical memorandum presents the Batch Test Leaching Model (BTLM), a simple, Tier 3 approach for assessing the potential impact to groundwater posed by leaching of contaminants from vadose-zone soils. The BTLM uses site-specific soil data to evaluate contaminant mobility and estimate contaminant concentrations in soil leachate. If the contaminant is deemed sufficiently mobile, the model predicts future impacts to groundwater based on simple leachate dilution assumption. This can then be compared to target groundwater action levels appropriate for the site. An Excel spreadsheet is included to facilitate use of the model. Use of the spreadsheet model only requires input of the concentration of the contaminant in soil (in mg/kg) and the result of the batch test analysis (in $\mu\text{g/L}$). The BTLM can also be used to develop more realistic, site-specific soil action levels in lieu of the conservative, Tier 1 action levels for this concern published by HDOH. This guidance will be updated periodically as additional information and improved approaches are identified.

The guidance is most pertinent to vadose zone soils. Direct monitoring of groundwater should be carried out to evaluate leaching of contaminants in soils situated below the water table. Guidance presented in this memo does not apply to the evaluation of waste being placed in regulated landfills or to hazardous waste determinations. Evaluation of waste to be placed in landfills must be carried out under direction of the HDOH Solid and Hazardous Waste Branch.

Introduction

At a screening level, leaching of contaminants from soil is the primary environmental concern for the majority of the organic contaminants presented in the Hawai'i Department of Health (HDOH) document *Screening For Environmental Concerns at Sites With Contaminated Soil and Groundwater* (i.e., Tier 1 soil action levels for leaching concerns are lower than action levels for direct exposure, vapor intrusion, ecotoxicity and gross contamination concerns, HDOH 2005). Site-specific evaluation is recommended when soil action levels for leaching concerns are exceeded. In addition, action levels for metals are not provided in the document and leaching concerns must again be evaluated on a site-by-site basis. However, easy-to-use and technically sound soil leaching models that can be applied to both organic and inorganic contaminants have been lacking. The guidance presented below is intended to help address this issue.

The guidance focuses on the use of laboratory batch tests to quantify the mobility of the contaminant in soil and estimate the initial concentration of the contaminant in soil leachate. Batch tests involve placing a small amount of the soil in buffered, de-ionized water, agitating the mixture for a set period of time and measuring the fraction of the contaminant that desorbs from the soil and goes into solution. The ratio of the mass of a contaminant that remains sorbed to the mass that goes into solution, adjusted to the test method, is referred to the contaminant's "desorption coefficient" or "Kd" value.

A contaminant's Kd value is a key parameter in soil leaching models. The lower the Kd value, the greater the mobility of the contaminant in soil and the greater the leaching threat. Contaminants with Kd values less than 1.0 are considered to be highly mobile and pose a significant threat to groundwater resources. Contaminants with Kd values greater than 20 are considered to be so tightly bound to the soil that they are essentially immobile and do not pose a significant leaching concern. The strength of binding can vary among different soil types, as well as contaminant concentration and the age of the release.

Batch test data can be input into an Excel spreadsheet model ("Batch Test Leaching Model (April 2007)) that accompanies this technical memorandum to calculate Kd values for target contaminants. Use of the model only requires input of the concentration of the contaminant in soil (in mg/kg) and the results of batch test analysis (in $\mu\text{g/L}$). Additional, default parameter values in the model can be adjusted if needed but this is generally not recommended. The concentration of the contaminant in leachate hypothetically derived from the soil tested is calculated based on the Kd value determined for the contaminant. The spreadsheet then estimates the ultimate concentration of the contaminant in groundwater based on a simple groundwater/leachate mixing model. The inclusion of a more refined approach for estimating contaminant concentrations in groundwater is anticipated for future updates to this guidance.

The remainder of this guidance provides a detailed discussion of contaminant partitioning in soil, key questions to be asked in site-specific leaching models, batch test methodologies for estimation of site-specific Kd values and calculation of contaminant concentrations in soil leachate and groundwater. Equations used in the Batch Test Leaching Model are presented in Appendix 1. The use of soil gas data to estimate concentrations of volatile contaminants in leachate is also briefly introduced. A detailed understanding of these topics is not necessarily needed to use the accompanying spreadsheets and carry out a simple, site-specific evaluation of potential soil leaching concerns using batch test data. A basic understanding of contaminant fate

and transport in the subsurface is very useful, however, in determining how confident one can be in applying the results of the models to actual field conditions.

This memo updates a previous November 2006 version of the guidance and replaces text regarding use of the SPLP test presented in the May 2005 edition of the HDOH document *Screening For Environmental Concerns at Sites With Contaminated Soil and Groundwater*” (Volume 1, Section 3.3.3; HDOH 2005). The approach described should be considered guidance only. Alternative approaches can be proposed for specific sites. This guidance will be updated as needed in the future. Comments and suggestions are welcome at any time and should be directed to Roger Brewer of HDOH at roger.brewer@doh.hawaii.gov.

Partitioning of Contaminants in Soil

Contaminants released into soil will partition into up to four different phases in the soil matrix (Figure 1). Some of the contaminant will dissolve into the soil moisture to form leachate. Another portion will chemically bind (“sorb”) to soil particles, primarily organic carbon and clay particles. If the contaminant is volatile, a portion will also partition into air-filled pore space as a vapor phase. If the total mass of the contaminant is great enough, the soil particles, soil moisture and soil vapor will become saturated and free-phase product will also be present.

In theory, the various phases of a contaminant will eventually come into equilibrium with each other. The nature of this equilibrium is controlled by the chemical properties of the contaminant, the chemistry and physical properties of the soil and the presence of other contaminants. Contaminants that readily bind to soil particles will be present primarily in the sorbed phase (e.g., PAHs, PCBs, etc.). Contaminants that are not very sorptive will accumulate in the soil moisture or soil vapor (e.g., perchlorate, chlorinated herbicides, BTEX, MTBE, solvents, etc.). Contaminants that are by nature gases will persist mainly as vapors in the air-filled pore space, especially if the soil is very dry (e.g., vinyl chloride).

In the absence of free product, the relationship between sorbed, dissolved and vapor phases of a contaminant in soil is relatively straightforward and can be described by simple partition coefficients (USEPA 2001). A contaminant’s “Henry’s Law Constant” is the ratio of the vapor-phase concentration of a contaminant to the dissolved-phase concentration, at equilibrium. The Henry’s Law Constant is relatively constant between sites, although it may vary slightly due to differences in soil temperature and the presence of other contaminants.

A contaminants sorption coefficient, or “Kd” value, is the ratio of the sorbed-phase concentration to the dissolved-phase concentration, at equilibrium (see Figure 1). For initial screening purposes and calculation of Tier 1 soil Action Levels, Kd values for organic chemicals are estimated using published *sorption* coefficients (“koc” values) and assumptions about the organic carbon content of the soil ($K_d = \text{published koc value} \times \text{assumed fraction organic carbon in soil, typically } 0.1\%$). Generic Kd values have also been published for a limited number of metals and other inorganic contaminants, although they are considered to much less reliable than for organic compounds. In the field, however, contaminant sorption (or more specifically “desorption”) coefficients can vary significantly between sites, due to differences in soil properties, the mixture of contaminants present and even the age of the release. The variability of contaminant Kd values in the field implies that this parameter should be included in site-specific evaluations of potential leaching concerns. In practice, this is rarely done.

A contaminant's Henry's Law Constant and assumed (or site-specific) K_d value can be used in conjunction with assumed or known soil properties to determine how the contaminant is actually distributed in the soil. Table 1 summarizes the distribution of several common contaminants in soil as assumed in the leaching models used to generate Tier 1 action levels published by HDOH (HDOH 2005). The percent mass in each phase is calculated based on rearrangement of a simple equilibrium partitioning equation presented in USEPA's *Soil Screening Guidance* (USEPA 2001, refer also to Appendix 1). Similar assumptions about contaminant partitioning in soil are made in the models used to generate the USEPA Preliminary Remediation Goals or Preliminary Remediation Goals, although this cannot be readily discerned from the equations presented in the accompanying guidance document (USEPA 2004).

As expected, contaminants such as benzo(a)pyrene and PCBs are almost entirely absorbed to soil particles (refer to Table 1). Perhaps surprising, however, is the tendency for the main mass of moderately volatile contaminants such as benzene, PCE and MTBE to be sorbed to soil particles or dissolved in soil moisture, versus being present as vapors in the soil air space. Confusion about this issue has led to over estimation (and probably over concern) of contaminant loss during sampling of soil for this group of chemicals. Compare this to contaminants that are gases and truly volatile by nature, such as vinyl chloride (see Table 1). Testing soil samples for the presence of vinyl chloride and estimating leaching concerns is probably not a worthwhile effort. The use of soil gas samples to estimate concentrations of highly volatile contaminants in soil leachate and even monitor the downward migrating vapor plumes is much more preferable. A brief introduction to this approach is provided later in this guidance and also included in the BTLM spreadsheet.

Site-Specific Evaluation of Soil Leaching Concerns

Four basic questions need to be posed when evaluating the potential for contaminants to leach from soil and impact groundwater (Figure 2):

1. "Is the contaminant potentially mobile?"
2. "What is the concentration of the contaminant in leachate in the primary source area?"
3. "What is the concentration of the contaminant in leachate at the point that the leachate reaches the top of the water table?" and
4. "What is the concentration of the contaminant in groundwater after the leachate has impacted the groundwater?"

Each of these relatively common sense and straight forward questions should be answered in a site-specific evaluation of potential soil leaching concerns. In practice, they rarely are, due in part to the "black box" nature of most soil leaching models. The guidance presented in this technical memorandum focuses on the first two of these questions, contaminant mobility and the initial concentration of the contaminant in leachate.

Mobility in Soil

Contaminant mobility in soil is evaluated in terms of how tightly bound the contaminant is to soil particles. From a modeling perspective, this is again described in terms of the contaminant's desorption coefficient or Kd value. Increasing Kd values reflect decreasing mobility in soil.

Figure 3 presents default, Tier 1 Kd values for several common contaminants and subdivides them in terms of relative mobility or leachability in soil (after Fetter 1993). Contaminants with a generic Kd value of less than 1.0 are considered to be highly mobile in soil, a fact that correlates well with field data and a list of common groundwater contaminants. Contaminants with a Kd value of greater than 20 in soil are considered to be essentially immobile. Not surprisingly, contaminants such as MTBE, PCE, BTEX, perchlorate and chlorinated pesticides like atrazine are predicted to be highly mobile in soil, at least at a screening level, whereas PAHs, PCBs and similar contaminants are considered to be essentially immobile. (Note that trace levels of strongly sorptive contaminants like chlordane in groundwater indicate that these contaminants can be mobile under some circumstances, especially if the leachate is migrating through unweathered bed rock.)

The ability of a contaminant to bind to soil is very much tied to the nature and concentration of the contaminant, the presence of other contaminants that may compete for prime sorption spots, the soil mineralogy and chemistry (including organic carbon and clay content) and the time elapsed since the release of the contaminant. Use of generic Kd values could in theory *under* predict how strongly bound a contaminant is to soil, especially in the presence of other contaminants or in soils with extreme pH, redox or other soil conditions. Based on (admittedly limited) data collected to date, however, generic Kd values typically used for organic contaminants tend to significantly *over* predict the potential mobility of contaminants in soils. This is especially true for organic contaminants. This makes the use of laboratory batch tests very important when Tier 1 action levels or screening levels for potential leaching concerns (based on generic Kd values) suggest that leaching concerns need to be further evaluated.

Initial Concentration in Leachate

A contaminant's Kd value is used in conjunction with its Henry's Law Constant and assumptions about soil properties to estimate the initial concentration of a contaminant in leachate. The relatively simple equation used to perform this calculation is presented in Appendix 1 and incorporated into the accompanying spreadsheet. The proportion of the contaminant that will move into soil leachate is again mainly controlled or reflected by the contaminant's Kd value. A Kd value less than 1.0 indicates that most of the contaminant will move into soil leachate in comparison to the fraction of the contaminant that will remain sorbed to soil particles.

Concentration in Leachate at Groundwater Interface

As the leachate migrates downward, contaminant concentrations can be progressively reduced due to resorption of the contaminant to soil particles, chemical or biological degradation or volatilization into the soil air space. Estimates of contaminant concentrations in leachate at the point that the leachate reaches the groundwater interface can be made using a vadose-zone fate and transport model. This important step is not included into the BTLM at this time. The BTLM model instead very conservatively assumes that the concentration of the contaminant in leachate at the groundwater interface is equal to that in the initial source area. A more detailed evaluation of contaminant fate and transport in soil leachate (e.g., using SESOIL, VLEACH or other

vadose-zone leaching models) may be particularly useful at sites where the depth to groundwater from the base of the contaminated soil is greater than approximately ten meters and target contaminants that have default K_d values greater than $1,000 \text{ cm}^3/\text{g}$ (e.g., naphthalene), are highly degradable (e.g., TPH and BTEX), and/or are moderately or highly volatile (e.g., PCE and vinyl chloride).

Concentration in Groundwater

The concentration of a contaminant in groundwater after mixing of the leachate with the groundwater can be estimated by either dividing the concentration of the contaminant in leachate by simple dilution factor or again by use of a more rigorous fate and transport model (refer to equations in Appendix 1). The BTLM model presented relies on the former, although a more refined approach may be added in the future.

The HDOH Environmental Action Levels document (or EAL Surfer) should be referred to for target groundwater goals (HDOH 2005). Target groundwater goals will in general be the lowest of the drinking water goal (i.e., lowest of Primary and Secondary MCLs or equivalents), surface water goal (assuming potential discharge to a body of surface water, acute or chronic aquatic toxicity goal based on site location) and any other applicable goals (vapor intrusion, gross contamination, etc.).

Use of Batch Test Data To Estimate Contaminant K_d Values

Relatively simple batch test methods have been in use for decades to evaluate leaching of metals from mine tailings and estimate the mobility of pesticides sprayed on agricultural lands (USEPA 1992, 1999). The tests collectively account for a host of factors that may control binding to (sorption) and leaching of (desorption) contaminants from soil. The tests do not identify exactly how the contaminant is bound to the soil, although a review of soil properties and chemistry can shed light on this issue if needed. The most commonly used batch test method to evaluate potential leaching of contaminants from soil is the *Synthetic Precipitation Leaching Procedure* or “SPLP” test (USEPA 1994, similar to the California “WET” test). The SPLP test is carried out as follows:

Step 1. Analyze soil sample for concentrations of target contaminants (e.g., in mg/kg)

Step 2. Run SPLP test on split sample:

- Place 100 grams soil in two liters of a de-ionized water solution (pH 5.5, 25° C),
- Remove airspace (especially for VOCs),
- Agitate 18 hours.

Step 3. Analyze extract for contaminants of concern.

Step 4. Estimate K_d by comparison of the mass of contaminant that remained sorbed to the soil to the mass of the contaminant that went into solution.

The equations used to calculate a contaminant’s K_d value in soil based on batch test data are provided in Appendix 1 and incorporated into the accompanying BTLM spreadsheet. The calculated K_d value is then used to evaluate the potential mobility of the contaminant in the soil

and estimate the initial concentration of the contaminant in soil leachate and groundwater, as described in the previous section.

For batch test results that are below standard, commercial lab Method reporting Limits (MRL), Kd can be estimated using 1/2 the MRL. If the estimated Kd is less than 20, a worst-case concentration of the contaminant in groundwater can be calculated as described above.

Contaminant Kd values estimated through use of batch tests apply only to the soil tested and only for the reported concentration of the contaminant in the soil. Kd values could vary with respect to contaminant concentration in the same soil type. This may need to be evaluated on a site-specific basis in cases where soil contamination is widespread and very heterogeneous.

For large areas where contaminant concentrations vary significantly and individual spill areas cannot be easily identified, it may be useful to conduct a series of batch tests and evaluate the variation in Kd with respect to contaminant concentrations in soil (keeping in mind the need to separate different soil types). Soil cleanup levels can then be developed by plotting contaminant concentration in soil versus estimated concentration in leachate, generating a regression line through the data (USEPA 1992, 1999). Soil cleanup levels can be calculated or read directly off of the graph by setting a target concentration of the contaminant in the leachate (e.g., target groundwater concentration times assumed groundwater/leachate dilution factor). An example of this approach based on perchlorate soil and SPLP data collected at a site in California is given in Figure 4. (Note that final cleanup standards varied slightly from that noted in the figure due to assumptions about representative contaminant distribution and Kd values in soil across the site.) In Hawai'i, this approach may be especially useful in the evaluation of large, pesticide mixing areas associated with former agricultural lands.

It is important to understand that batch tests were not designed to directly estimate the concentration of a contaminant in soil leachate. Batch tests were instead designed to calculate Kd sorption or desorption coefficients, which can then be used to estimate contaminant concentrations in leachate if desired. The volume of solution used in batch test can be used to illustrate this point. A solution volume of two liters was selected primarily to help ensure that laboratory detection limits could be met, not to mimic the supposed concentration of the contaminant in actual soil leachate – as is commonly misinterpreted (USEPA 1992). If the same mass of soil (generally 100 grams) were placed in a swimming pool-size volume of solution then the resulting concentrations of target contaminants in the batch test would of course be very different. Assuming that the contaminant is not completely stripped from the soil, however, the ratio of the mass that remains sorbed to the mass that moves into solution (i.e., the Kd value) should be constant. For highly sorptive contaminants (e.g., PCBs and PAHs) and for many metals, the difference between batch test results and calculated concentration of the contaminant in leachate may indeed be very small. For less sorptive contaminants like BTEX, MTBE, perchlorate and moderately mobile pesticides, however, estimated concentrations in leachate may be an order of magnitude or more greater than the concentration reported in the batch test data. This is especially true for contaminants with Kd values less than 20 in the soil tested, where a significant fraction of the contaminant partitions into the batch test solute (e.g., >25%).

Soil Sampling Strategies

A minimum of three soil samples is generally needed to validate batch test data for each area investigated. Recording the soil type and testing for the total organic carbon content and percent clay content of the soil is also recommended. Although not directly incorporated into the BTLM, this information may prove useful in understanding the nature of contaminant binding in the soil and help direct soil cleanup actions, if needed.

For large sites with varying soil types, contaminant mixtures or release histories, it may be necessary to define multiple “decision units” and evaluate each area separately. For example, the binding capacity of sandy soils is likely to be much lower than clayey or organic-rich soils. If both soil types are present at a contaminated site, it would be prudent to treat each soil type area as a separate decision unit.

The collection and analysis of multi-increment samples (essentially very good “composite” samples) is preferred for easily identifiable spill areas or “hot spots,” especially where the primary contaminants are non-volatile. Collection and field-based extraction of multi-increment samples for volatile contaminants may also be feasible, although this subject is beyond the current scope of this memo. Guidance on the collection and evaluation of multi-increment samples is currently being prepared by HDOH. In the interim, and especially for cases under the formal oversight of HDOH, it is recommended that potential users of the BTLM guidance review sampling plans with the HDOH project manager prior to collection and submittal of the samples for analysis.

Use of Soil Gas Data to Evaluate Groundwater Protection Concerns

Batch tests can be used to evaluate both nonvolatile and volatile contaminants, although special care must be taken during sampling and testing of the latter (refer to USEPA 1994 SPLP method guidance). The concurrent use of soil gas data to estimate the concentration of volatile contaminants in soil leachate may also be prudent. Reasonably accurate estimations of the contaminant concentrations in soil moisture or leachate can be made by dividing the concentration of the contaminant in soil gas (converted to ug/L) by the chemical’s dimensionless Henry’s Law Constant (see equation in Appendix 1). A simple model based on this approach and incorporating a groundwater:leachate dilution factor is presented in Appendix 1 and included in the BTLM spreadsheet.

Cases where soil gas data may prove beneficial for evaluation of potential impacts to groundwater include: 1) sites with releases of relatively persistent, volatile chemicals that remain very dry throughout much of the year (i.e., non-irrigated areas with very low precipitation, or paved areas that overlie shallow groundwater), 2) sites known to be impacted by volatile contaminants but where specific source areas have not been identified, 3) sites where the threat to groundwater is primarily posed by downward releases of vapors from underground tanks, pipelines, etc., and 4) sites where the vulnerability and sensitivity of the first-encountered groundwater resource is very high (e.g., unconfined aquifer that is currently used as a source of drinking water). In very wet or heavily irrigated areas (e.g., groundwater recharge greater than ten inches or 25cm per year), mass loading of the contaminant to groundwater via vapor-phase

plumes is likely to be insignificant in comparison to contaminant migration via leachate. In very dry areas, however, the amount of moisture in the soils may not be sufficient to initiate the downward migration of leachate by the force of gravity. If this is the case then the model discussed above will overstate the potential threat to groundwater posed by dissolved-phase contaminants in the soil moisture.

A focus on the potential for vapor plumes to impact groundwater will be more appropriate for dry areas. Easy-to-use models that specifically evaluate the downward migration of vapor plumes to groundwater are not currently available. An evaluation of potential groundwater impact concerns may instead have to rely on long-term monitoring of soil gas in the vadose zone. Soil gas “action levels” for protection of groundwater can be developed by rearranging the Henry’s Law Constant equation to solve for the concentration of the contaminant in soil vapor and setting the dissolved-phase concentration of the contaminant equal to a target groundwater or leachate goal (refer to equations in Appendix 1).

Soil gas data will be less useful for estimation of semi-volatile contaminant concentrations in leachate. This is due to the very low Henry’s Law Constants for these contaminants and associated limitations on soil gas method reporting limits. As noted in Table 1 for PAHs, the overwhelming majority of the contaminant mass will also be sorbed to the soil, rather than in the soil vapor. Batch tests on representative soil samples therefore offer a better approach for the evaluation of leaching concerns related to these contaminants.

Leaching of Heavily Contaminated Soils

Soils that contain significant amounts of pure-phase or “free” product” may not be amenable to use of the Batch Test Leaching Model as described above (i.e., contaminant that is not sorbed to the soil, dissolved into the soil moisture or present as vapors in air-filled pore space). This is particularly true for soils that are heavily contaminated with petroleum. Contaminant K_d values can only be calculated if any free product present completely dissolves into the batch test solution. If free product forms in the batch test solution then analysis of solution for dissolved-phase constituents will not accurately reflect the total mass of contaminants that were stripped from the soil during the test. This will cause the model to over predict the mass of the contaminant that remained sorbed to the soil and in turn over predict the contaminants K_d value.

If the reported concentration of a contaminant in a batch test analysis exceeds 75% of the assumed solubility then it should be assumed that pure-phase contaminant product may be present in the batch test solution. In such cases, the spreadsheet model will generate a caution message and a K_d value will not be calculated. The potential mobility of the contaminant with respect to its K_d value therefore cannot be accurately evaluated. In the spreadsheet model, the estimated concentration of contaminant in soil leachate is set to the highest of the contaminant’s solubility and the reported concentration of the contaminant in the batch test analysis. Potential impacts to groundwater are estimated by dividing the assumed concentration of the contaminant in leachate by the input groundwater:leachate dilution factor. The potential downward mobility of liquid-phase free product in the soil should also be further evaluated.

Special Considerations For Petroleum-Contaminated Soils

Soils impacted by petroleum should be tested for both Total Petroleum Hydrocarbons (TPH) and target indicator compounds, including BTEX, MTBE and related fuel oxygenates and the PAHs naphthalene and methylnaphthalene (refer to Volume 1, Section 2.2.2 in HDOH EAL document, HDOH 2005). Testing for other PAHs is not necessary, due to their relative immobility in soil and low concentration in most petroleum products.

Problems related to the presence of free product in the batch test solution as discussed above could be especially pronounced for soils heavily impacted with middle distillates (diesel, jet fuel, etc.) and heavier residual fuels (waste oil, hydraulic fluid, etc.). The low solubility of these fuels in comparison to gasoline can lead to the presence of droplets of free product in soil at concentrations above only a few hundred parts-per-million (mg/kg) TPH. At high enough concentrations, this could lead to the presence of free product in the batch test solution. This will negate use of the BTLM model to calculate a K_d value for the sample tested and evaluate the potential mobility of the contaminant, as discussed in the previous section.

If the batch test results for Total Petroleum Hydrocarbons (TPH) suggest the potential presence of free product in the solution then the concentration of TPH in soil leachate should be assumed to be equal to the higher of the reported result and the assumed solubility of the targeted petroleum product. In the absence of a more site-specific review, the potential concentration of the contaminant in groundwater should be estimated by dividing the concentration in leachate but the groundwater:leachate dilution factor selected for the site. This is automatically carried out in the accompanying BTLM spreadsheet.

The presence of potentially mobile free product in the soil should also be evaluated. This can be done by comparison of TPH data for vadose-zone soil to HDOH action levels for gross contamination concerns in subsurface soils (HDOH 2005, Appendix 1). An action level of 2,000 mg/kg for gasoline contaminated soils. A somewhat higher action level 5,000 mg/kg is used for soils contaminated with either middle range petroleum distillates (e.g., diesel fuel and jet fuel) or residual fuels (motor oil, waste oil, etc.). These action levels are intended to minimize the presence of mobile free product in soil and are based on field observations and published studies (e.g, API 2000). Minimum conditions for use of the action levels in other areas include: 1) the source of the release has been eliminated, 2) grossly contaminated soil has been removed to the extent practicable (e.g., within 15 feet of the ground surface and/or to the top of bedrock) and 3) remaining contamination does not threaten nearby water supply wells or aquatic habitat (refer also to Volume 1, Section 2.2 of the HDOH 2005 EAL document).

Residual petroleum contamination in soil can be expected to naturally degrade over time. Note that impacted soil that is disturbed during future subsurface activities must also be properly managed. Continued groundwater monitoring may also be required for highly sensitive sites. Additional guidance for the long-term management of petroleum-contaminated soil (and groundwater) is currently being prepared by HDOH.

Other Limitations

Evaluation of Past Impacts to Groundwater

The approach described in this technical memorandum can only be used to predict *future* leaching of contaminants from soil and subsequent impacts to groundwater. Batch tests on residual contaminants in soil cannot necessarily be used to predict if *past* impacts to groundwater may have occurred. In part this is because the contaminants may be much more strongly bound to soil particles under current conditions than during the initial release. The possibility of past impacts to groundwater must be evaluated on a site-by-site basis, based on the nature of the contaminant released, the subsurface geology and the depth to groundwater among other factors.

Placement of Soil Below Water Table

The batch test method may not accurately mimic the placement of contaminated soil or other media below the water table for long periods of time and should not be used to predict these conditions. Long-term immersion could significantly enhance desorption of contaminants, especially if rate-limited processes such as desorption, organic carbon decay or mineral dissolution affect contaminant partitioning. Long-term immersion of the soil could increase impacts to groundwater that significantly exceed levels predicted by short-term batch tests. In the absence of a more detailed groundwater impact study, placement of contaminated soil below the water table or at a depth that is subject to future inundation by a rise in groundwater should be avoided (e.g., areas where the water table has dropped significantly due a prolonged dry period but is expected to rise again in the future). If this cannot be avoided and nearby water supply wells or aquatic habitats could be threatened, then long-term monitoring of the groundwater to verify that the contaminants are not significantly mobile is probably warranted.

Long-Term Groundwater Monitoring

Although the batch test method is believed to be very accurate, long-term groundwater monitoring may be prudent in some cases to verify the results of the evaluation. Monitoring may be especially warranted at sites where batch test data suggest that relatively high concentrations of chlorinated solvents, pesticides or other persistent contaminants can be left in place (e.g., in comparison to Tier 1 action levels for leaching concerns) but important drinking water resources are potentially threatened. Monitoring may also be needed at site where subsurface conditions could change over time and allow for increased leaching of contaminants (e.g., rising water table).

Use of K_d Values in Fate & Transport Models

Contaminant K_d values derived from batch tests cannot necessarily be incorporated into vadose-zone fate and transport models for deeper soils, even if the soil types are very similar. This is because the K_d value most likely reflects an increased difficulty in desorbing or leaching of *aged* contaminants from the tested soil. Use of the K_d value to evaluate migration of the contaminant in leachate through deeper soils not yet impacted by the initial release could over predict *resorption* to soil particles thus *under* predict potential impacts to groundwater. The use of batch tests to estimate site-specific *sorption* coefficients for contaminants in deeper soils may be practical but is beyond the current scope of this technical memorandum.

Evaluation of Solid or Hazardous Waste

Guidance presented in this memo does not apply to the evaluation of waste being placed in regulated landfills or to hazardous waste determinations. Evaluation of waste to be placed in landfills must be carried out under direction of the HDOH Solid and Hazardous Waste Branch.

References:

- API, 2000, *Non-Aqueous Phase Liquid (NAPL) Mobility Limits in Soil*: American Petroleum Institute (June 2000), Soil and Groundwater Research Bulletin, No.9.
- Fetter, C. W., 1993, *Contaminant Hydrogeology*: Macmillan Publishing Company, New York, New York, ISBN 0-02-337135-8.
- HIDOH, 1995, *Environmental Corrective Action and Decision Making at Sites With Contaminated Soil and Groundwater*: State of Hawai'i, Department of Health, December, 1995 (revised June, 1996).
- HIDOH, 2005, *Screening For Environmental Concerns at Sites With Contaminated Soil and Groundwater* (May 2005 and updates): Hawai'i Department of Health, Hazard Evaluation and Emergency Response Office, www.hawaii.gov/health/environmental/hazard/eal2005.html.
- McLean, J.E. and B.E. Bledsoe, 1992, *Behavior of Metals in Soil*, U.S. Environmental Protection Agency, Office of Solid Waste and Emergency Response, EPA/540/S-92/018.
- Roy, W.R; Krapac, I.G.; Chou, S.F.J.; and R.A. Griffin, 1992, *Batch Type Leaching Procedures For Estimating Soil Absorption of Chemicals*, U.S. Environmental Protection Agency, Office of Solid Waste and Emergency Response, EPA/530/SW-87/006-F.
- USEPA, 1994, *Synthetic Precipitation Leaching Procedure*: U.S. Environmental Protection Agency, Office of Solid Waste, SW-846 Method 1312, September 1994, www.epa.gov/epaoswer/hazwaste/test/main.htm.
- USEPA, 1999, *Understanding Variation in Partition Coefficient, K_d, Values*: Office of Air and Radiation, August 1999, EPA/402/R/99/004A, <http://www.epa.gov/radiation/docs/kdreport/>
- USEPA, 2001, *Supplemental Guidance For Developing Soil Screening Levels For Superfund Sites* (Peer Review Draft, May 2001): U.S. Environmental Protection Agency, Office of Solid Waste and Emergency Response, Publication 9355.4-24.
- USEPA, 2004, *Preliminary Remediation Goals*: U.S. Environmental Protection Agency, Region IX, October 2004, www.epa.gov/region09/waste/sfund/prg/index.htm.

Table 1. Distribution of contaminants in soil based on contaminant properties and soil characteristics assumed in Tier 1 leaching models. Note how the fraction of the contaminant in the dissolved-phase is strongly tied to the assumed sorption coefficient or “Kd” value.

Chemical	Default Sorption Coefficient (Kd)	*Contaminant Phase Versus Percent Total Mass in Soil		
		Sorbed	Dissolved	Vapor
Arsenic	29	99.9+%	0.0004%	0%
Benzo(a)pyrene	5,500	99.9+%	0.002%	0%
PCBs	33	99.7%	0.3%	0.01%
TPH	5.0	98%	1.9%	0.1%
Atrazine	0.23	70%	30%	0%
PCE	0.16	39%	25%	35%
Benzene	0.059	29%	50%	21%
MTBE	0.006	5%	91%	4%
Vinyl Chloride	0.0	5%	31%	64%

*Based on soil equilibrium partitioning equation presented in USEPA *Soil Screening Guidance* (USEPA 2001). Leachate is represented by the dissolved-phase mass of the contaminant. For organic contaminants, Tier 1 Kd value = published sorption coefficient (Koc) x assumed total organic carbon content in soil of 0.1% (refer to HDOH 2005, Appendix 1, Table H). Assumes and soil moisture content of 0.10. Arsenic default Kd from USEPA *Soil Screening Guidance*.

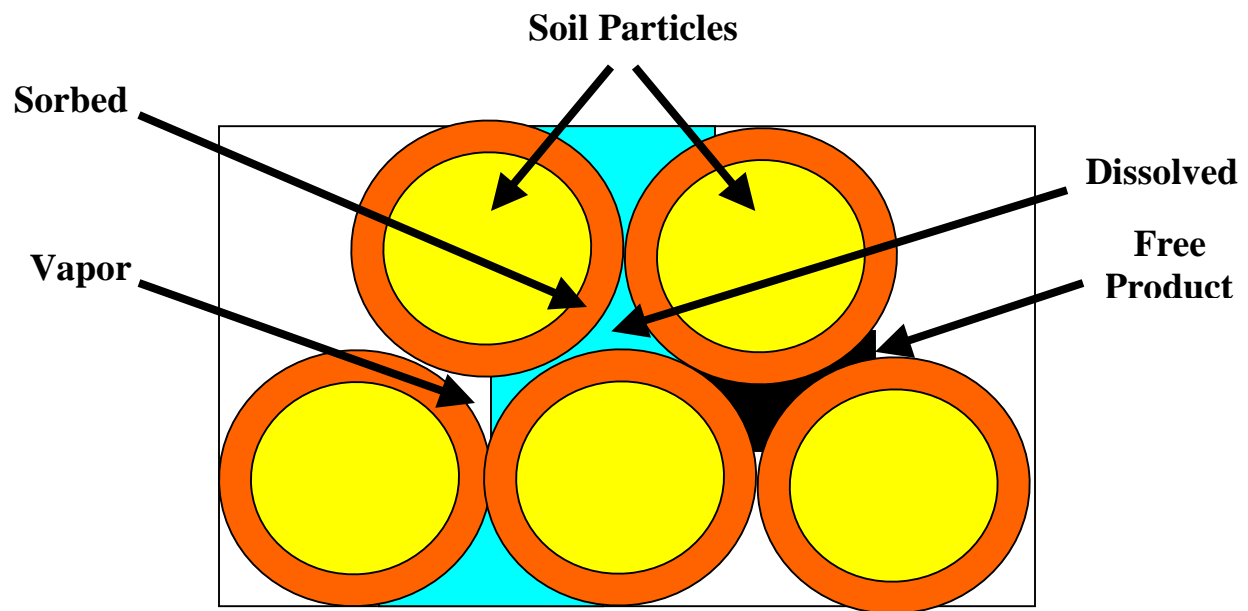

Partition Coefficients

$K_d = \text{Sorbed Concentration} / \text{Dissolved Concentration}$

Henry's Law constant = $\text{Vapor Concentration} / \text{Dissolved Concentration}$

Figure 1. Partitioning of contaminants in soil between sorbed, dissolved and vapor phases.

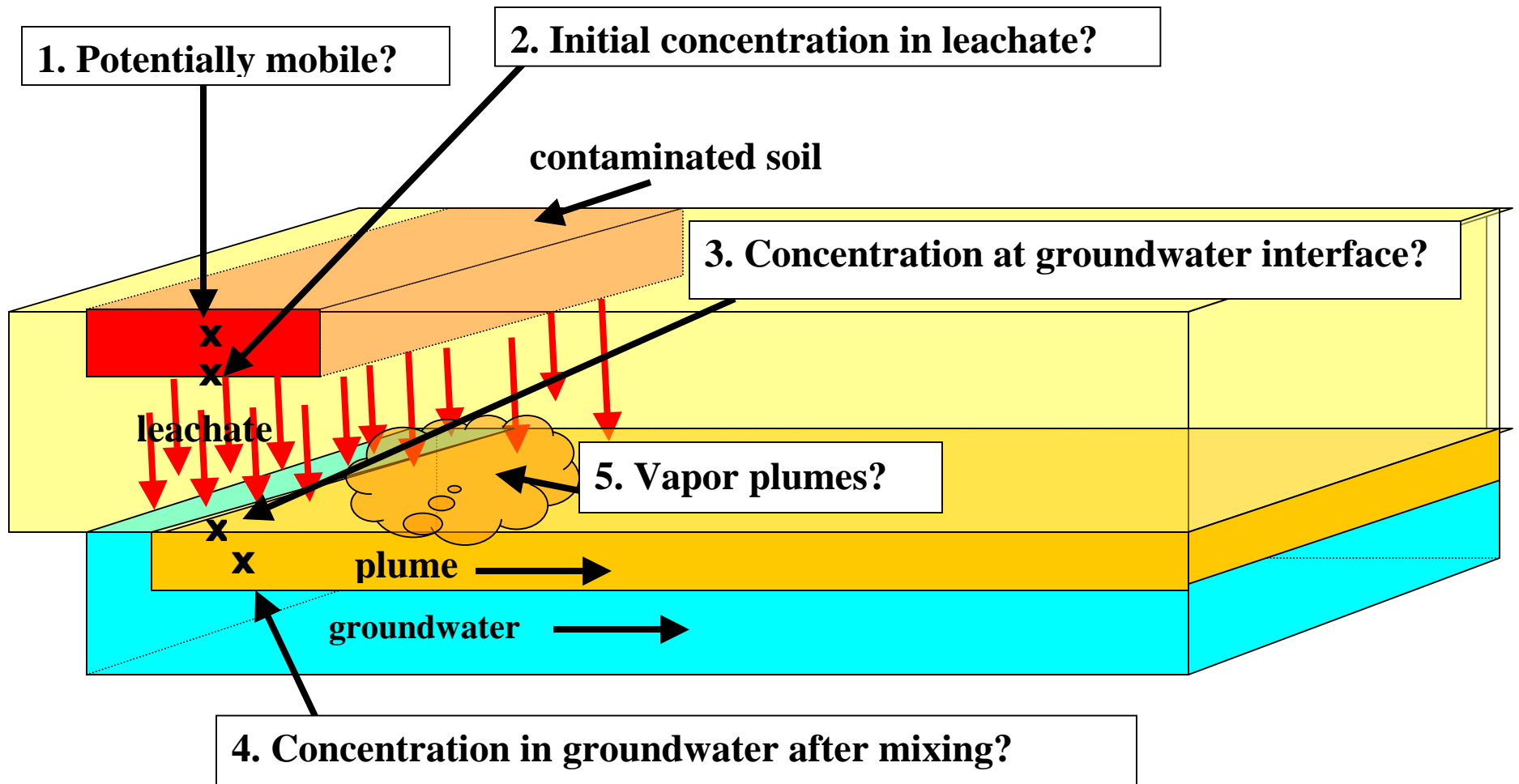

Figure 2. Basic questions that should be answered in all site-specific evaluations of soil leaching concerns. The guidance focuses on site-specific approaches to answering Questions 1 and 2, although approaches for answering the remaining questions are also provided.

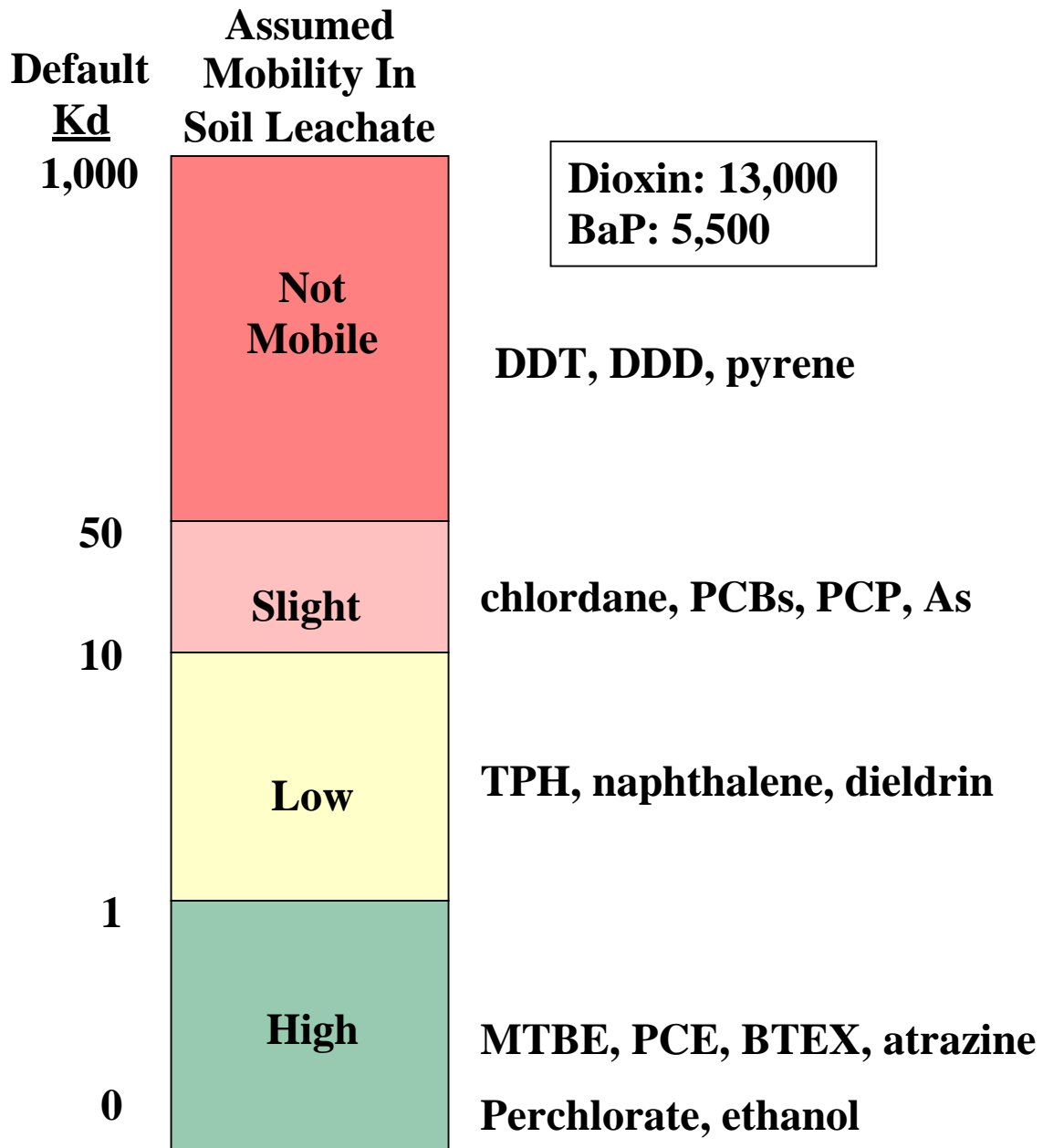

Figure 3. Assumed mobility of contaminants in soil leachate with respect to default K_d values used to develop HDOH Tier 1 soil action levels for leaching concerns. For organic contaminants, K_d values based on published K_{oc} sorption coefficients and total organic carbon content in soil of 0.1% (refer to Appendix 1 in HDOH EAL document, HDOH 2005). For arsenic, default K_d value of 29 from USEPA *Soil Screening Guidance* (USEPA 2001).

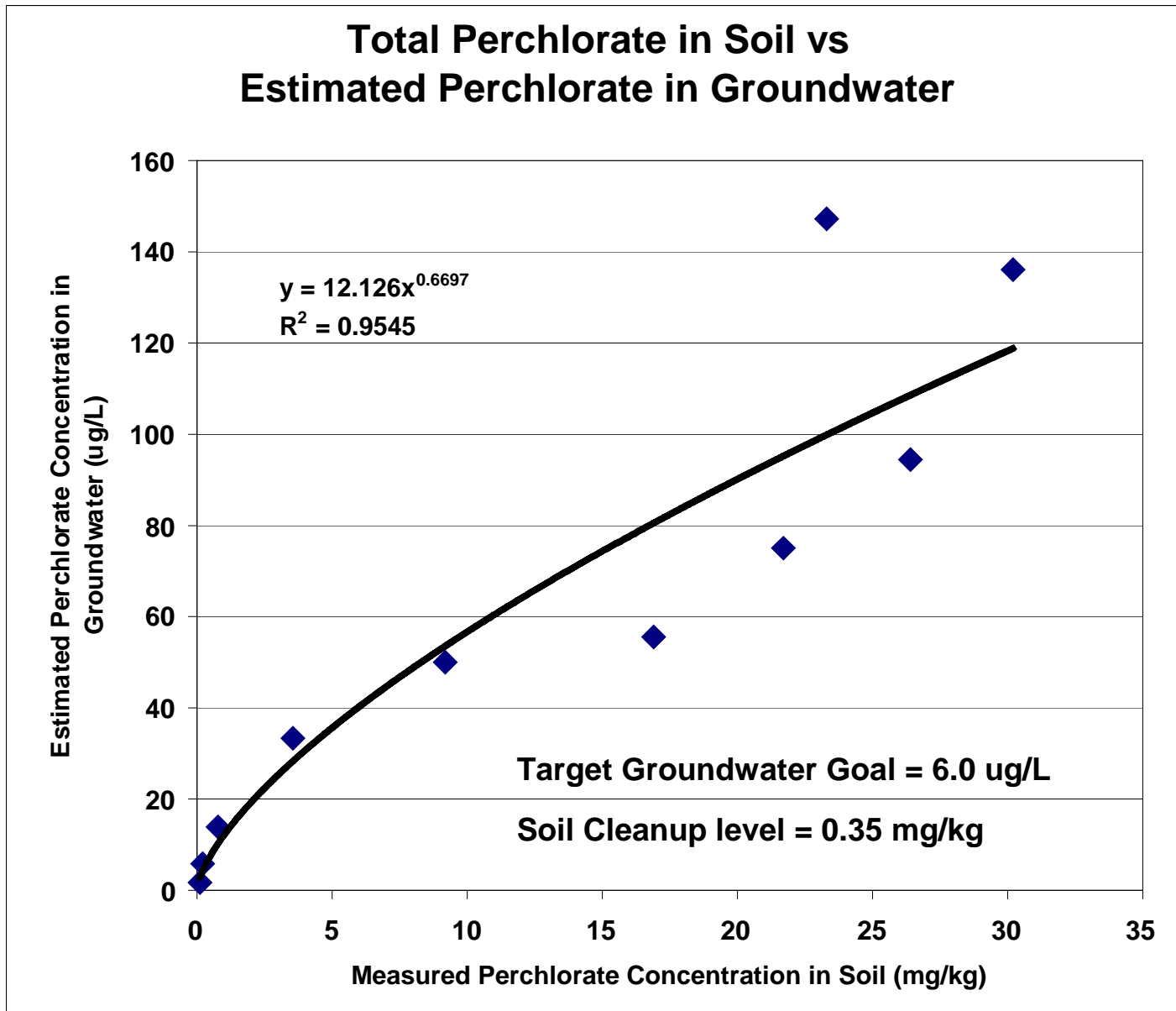

Figure 4. Example graphical calculation of soil cleanup levels based on use of multiple batch tests to estimated perchlorate desorption coefficients and correlative concentrations of perchlorate in soil leachate and groundwater at varying soil concentrations of perchlorate in soil. (For example only.)

Batch Test Leaching Model

Version: April 2007

Hawai'i Department of Health

Hazard Evaluation and Emergency Response Office

Contact: Roger Brewer (roger.brewer@doh.hawaii.gov)

- Refer to accompanying technical memorandum for background and use of this spreadsheet (HDOH 2007).
- Spreadsheet calculates Kd desorption coefficient based on input contaminant concentration in soil and Batch Test data.
- Correlative concentration of contaminant in leachate calculated based on estimated Kd value (may differ from batch test data).
- Future impacts to groundwater estimated using simple groundwater/leachate dilution factor.
- Alternative model based on soil gas data provided in accompanying worksheet.
- Possibility of past impacts to groundwater not considered and must be evaluated separately.
- Check to ensure that this is an up-to-date version of the spreadsheet.
- Password to unprotect worksheet is "EAL" (under Tools menu).**

STEPS:

1. Select chemical from pulldown list (unlisted chemicals - unprotect spreadsheet and input chemical name and chemical constants).
2. Input total contaminant concentration and SPLP (or other applicable batch test) concentration.
3. Input sample properties. Use default values if sample-specific data are not available.
4. Input Batch Test method information. Default SPLP method parameter values noted.
5. Input groundwater:leachate dilution factor (DF of 1.0 = no dilution; USEPA default = 20, USEPA 2001).
6. Input target groundwater action level for comparison to model calculation of groundwater impacts (optional).
7. Spreadsheet calculates sample-specific Kd value and dissolved-phase concentration of contaminant in saturated sample.
8. Spreadsheet calculates concentration of contaminant in groundwater following impact by leachate.

Step 1: Select Contaminant (use pulldown list)

PERCHLORATE

Step 2: Input Sample Data	DEFAULT	INPUT
¹ Concentration in soil sample (mg/kg)	N/A	9.2E+00
¹ Concentration in Batch Test solution (ug/L)	N/A	3.7E+02
Step 3: Input Sample Properties (⁵ USEPA soil defaults noted)		
Sample density (g/cm ³)	1.50	1.50
Particle density (g/cm ³)	2.65	2.65
Fraction air-filled porosity (assume saturated soil)	0.00	0.00
Step 4: Batch Test Method Data (SPLP defaults noted)		
² Batch Test Solution Volume (ml):	2,000	2,000
² Batch Test Solution Density (g/cm ³):	1.0	1.0
² Batch Test Sample Weight (grams)	100	100

Step 5: Input Groundwater/Leachate Dilution Factor	DEFAULT	INPUT
	20	20
Step 6 (optional): Input Target Groundwater Concentration (ug/L)		5.0E+00
Model Results		
⁵ Kd partition Coefficient (cm ³ /g):		4.8E+00
⁶ Estimated Concentration in Source Area Leachate (ug/L):		1.8E+03
⁷ Estimated Concentration in Groundwater (ug/L):		9.0E+01

Chemical Constants (selected from Constants worksheet)

Kh (atm m ³ /mole)	0.00E+00
Kh (dimensionless)	0.00E+00
Solubility (ug/L)	2.00E+08

Calculations:

Sample porosity - total	0.43
Sample porosity - air-filled	0.00
Sample porosity - water-filled	0.43
Batch Test Solution Mass (grams)	2.0E+03
Batch Test Sample Mass (grams)	1.0E+02
Sample Mass:Solution Mass Ratio (gm/gm)	5.0E-02
Total Mass of Contaminant (ug)	9.2E+02
Mass Contaminant in Batch Test Solution (ug)	7.4E+02
Mass Contaminant Sorbed to Soil (ug)	1.8E+02
Concentration Sorbed (ug/kg)	1.8E+03
Batch Test Percent Solid Phase	19.3%
Batch Test Percent Dissolved Phase	80.7%
Batch Test Solid-Phase Contaminant Conc. (mg/kg)	1.8E+00
Batch Test Solution Contaminant Conc. (ug/L)	3.7E+02

Kd <20. Contaminant potentially mobile in leachate for concentration and soil type tested. Soil leaching and groundwater impact concerns must be addressed if target groundwater action level is exceeded.

Figure 5. Main page of HDOH Batch Test Leaching Model that accompanies the technical memorandum (as of April 2007).

Appendix 1
Batch Test and Soil Gas Leaching Model Equations

Batch Test Leaching Model Equations

The equations discussed below are incorporated into the Excel-based Batch Test Leaching Model that accompanies this technical memorandum. Figure 5 in the main text depicts the first page of the model (April 2007 version). The model will be updated as needed in the future.

Step 1. Calculate a partition coefficient for each chemical of potential concern.

The results of the SPLP test can be used to develop a sample-specific partition coefficient (Kd) for each chemical of potential concern. The partition coefficient is calculated as follows (after Roy et. al, 1992; see also McClean and Bledsoe, 1992, and USEPA 1999):

$$Kd (L / kg) = \frac{Concentration_{sorbed} (\mu g / Kg)}{Concentration_{solution} (\mu g / L)} \quad (1)$$

where $Concentration_{sorbed}$ is the concentration of the contaminant that remained sorbed to the soil following the batch test and $Concentration_{solution}$ is the resulting concentration of the contaminant in the batch test solution. The term Kd is commonly reported in equivalent units of (ug/g)/(ug/cm³) or cm³/g, based on an assumed batch test solution density of 1.0 g/cm³.

The sorbed concentration of the contaminant is calculated as follows:

$$Concentration_{sorbed} (\mu g / kg) = \frac{Mass_{sorbed} (\mu g)}{Sample Mass (kg)} \quad (2)$$

where $Mass_{sorbed}$ is the mass of the contaminant still sorbed to the soil following the batch test. The mass of the sample called for in the SPLP batch test is 100 grams or 0.1 Kg (USEPA 1994).

The mass of the contaminant sorbed to the soil is calculated by subtracting the mass of the contaminant that went into the batch test solution from the initial, total mass of the contaminant in the soil sample:

$$Mass_{sorbed} (\mu g) = Mass_{total} (\mu g) - Mass_{solution} (\mu g) \quad (3)$$

where $Mass_{total}$ is original, total mass of the contaminant in the soil sample and $Mass_{solution}$ is the mass of the contaminant in the batch test solution. The total mass of the contaminant in the soil sample is calculated as:

$$Mass_{total} (\mu g) = Concentration_{total} (mg / kg) \times \left(\frac{1,000 \mu g}{1 mg} \right) \times Sample Mass (kg) \quad (4)$$

where $Concentration_{total}$ is the reported total concentration of the contaminant in the soil sample that used in the batch test (tested on a split sample). The mass of the contaminant in the batch test solution is calculated as:

$$Mass_{solution} (\mu g) = Concentration_{solution} (\mu g / L) \times Solution Volume (L) \quad (5)$$

The default volume of solution used in SPLP batch tests is two liters (USEPA 1994).

Note that use of the batch test method to estimate Kd values is not longer valid if the solubility limit of the contaminant is exceeded in the batch test solution (refer to section on Leaching of Heavily Contaminated Soils in the main text). Exceeding the contaminants solubility suggests that free product is present in the soil (either liquid or dry). As a precautionary measure, a cutoff of 75% the assumed contaminant solubility is used in the Batch Test Leaching Model spreadsheet to identify if free product may be present in the batch test solution. The free product acts as a second reservoir of contaminant mass that will bias the true equilibrium concentration of the contaminant in the dissolved and sorbed phases. To accurately calculate desorption coefficients, batch test analyses must be run samples with lower concentrations of the contaminant in soil.

Step 2. Estimate the concentration of the contaminant in source-area leachate.

Once the soil-specific Kd value for a target contaminant has been determined, it is relatively simple to estimate the concentration of the contaminant in the soil moisture or “leachate” within the main body of contaminated soil or the leachate “source area”). This is done by incorporating the calculated Kd into a simple equilibrium partitioning equation and assuming default (or site-specific) soil properties (after USEPA 2001):

$$C_{\text{total}} = C_{\text{leachate}} \times \left(Kd + \left(\frac{\theta_w + (\theta_a \times H')}{\rho_b} \right) \right) \times \left(\frac{1\text{mg}}{1000\mu\text{g}} \right) \quad (6)$$

where: C_{total} = Total concentration of chemical in sample (mg/kg);
 C_{leachate} = Dissolved-phase concentration of chemical ($\mu\text{g/L}$);
 Kd = Estimated or measured partition coefficient L/kg;
 θ_{w} = water-filled porosity ($L_{\text{water}}/L_{\text{soil}}$);
 θ_{a} = air-filled porosity ($L_{\text{air}}/L_{\text{soil}}$);
 H' = Henry's Law Constant at 25°C ($(\mu\text{g/L-vapor})/(\mu\text{g/L-water})$); and
 ρ_b = Soil bulk density (Kg/L).

Table H in Appendix 1 of the HDOH EAL document provides a summary of “dimensionless” Henry's Law Constants (H') for common volatile contaminants (HDOH 2005). For the purpose of calculating Tier 1 action levels, Kd is calculated as the chemical's published organic carbon partition coefficient (koc) times the fraction organic carbon in the soil (foc). This is discussed in Appendix 1 of the HDOH Environmental Action Levels document (HDOH 2005). Note that in this equation Kd and ρ_b are expressed in units of L/Kg and Kg/L, respectively, rather than in equivalent units of cm^3/g and g/cm^3 . A default soil density of 1.5 Kg/L and soil porosity of 43% (0.43) are typically used in Tier 1 risk assessment models (e.g., USEPA 2001, 2004).

Equation 6 can be rearranged to solve for C_{leachate} as follows:

$$C_{\text{leachate}} = C_{\text{total}} \div \left(\left(Kd + \left(\frac{\theta_w + (\theta_a \times H')}{\rho_b} \right) \right) \times \left(\frac{1\text{mg}}{1000\mu\text{g}} \right) \right). \quad (7)$$

This equation is incorporated into the “Batch Test Leaching Model” worksheet of the Excel file that accompanies this technical memo. The sorption coefficient should be used to estimate the dissolved-phase concentration of the contaminant in a hypothetical, saturated sample of soil at equilibrium and at the same contaminant concentration as the SPLP test. Since the soil is assumed to be fully saturated with water, the vapor-phase term of the equation “ $\theta_a \times H'$ ” goes to zero.

Step 3. Tier 3 calculation of ultimate contaminant concentration in groundwater.

A conservative estimate of the contaminant concentration in groundwater that could be impacted by the leachate is made by dividing the calculated concentration of the contaminant in leachate by an assumed groundwater:leachate dilution factor (DF):

$$C_{\text{groundwater}} = \frac{C_{\text{leachate}}}{\text{DF}} \quad (8)$$

$$\text{DF} = \frac{\text{Volume Impacted Groundwater}}{\text{Volume Leachate}}. \quad (9)$$

where: $C_{\text{groundwater}}$ = Concentration of chemical in groundwater ($\mu\text{g/L}$);
 C_{leachate} = Concentration of chemical in leachate ($\mu\text{g/L}$); and
 DF = Groundwater/Leachate dilution factor (m^3/m^3).

This equation is incorporated into the Batch Test Leaching Model spreadsheet that accompanies this technical memo. A default DF of 20 is considered appropriate for sites less than or equal to 0.5 acres in size (USEPA 2001). A more site-specific DF factor can be calculated if needed, based on the following equation (USEPA 2001):

$$\text{Dilution Factor} = 1 + \left(\frac{K \times i \times d}{I \times L} \right) \quad (10)$$

where “K” is the aquifer hydraulic conductivity (m/year), “i” is the regional hydraulic gradient, “d” is the assuming mixing zone depth (default is two meters), “I” is the surface water infiltration rate (m/year” and “L” is the length of the contaminated soil area that is parallel to groundwater flow (m).

Note that this equation does not consider an expected reduction in contaminant concentrations as the leachate migrates downward. This component of the evaluation can be included in more site-specific evaluations as needed.

Soil Gas Leaching Model

For volatile contaminants, soil gas data offer an alternative approach for estimation of contaminant concentrations in leachate as well as a method to evaluate the threat posed to groundwater by downward migrating vapor plumes. The relationship between vapor-phase and dissolved-phase volatile chemicals under equilibrium conditions is relatively straightforward:

$$H' = \frac{C_{\text{vapor}} \text{ (ug / L)}}{C_{\text{leachate}} \text{ (ug / L)}} \quad (11)$$

where: H' = Henry's Law Constant at 25°C;
 C_{vapor} = Vapor-phase concentration in soil gas;
 C_{leachate} = Dissolved-phase concentration in soil pore waters.

Table H in Appendix 1 of the HDOH EAL document provides a summary of "dimensionless" Henry's Law Constants (H') for common volatile contaminants (HDOH 2005). To calculate the concentration of the contaminant in the soil moisture the equation is rearranged to solve for " C_{leachate} ." The C_{vapor} term is also adjusted to units of ug/m³ to correspond with the units typically reported in site data:

$$C_{\text{leachate}} \text{ (ug / L)} = \frac{C_{\text{vapor}} \text{ (ug / m}^3\text{)} \times \frac{1 \text{ m}^3}{1,000 \text{ L}}}{H'} \quad (12)$$

Equation 8 above can be used to estimate potential impacts to groundwater with respect to soil gas-based estimates of contaminant concentrations of the in leachate.

Soil gas "action levels" for protection of groundwater can be developed by rearranging the equation to solve for C_{vapor} and setting C_{leachate} equal to a target leachate goal (e.g., groundwater action level times appropriate groundwater:leachate dilution factor):

$$C_{\text{vapor}} \text{ (ug / m}^3\text{)} = C_{\text{leachate}} \text{ (ug / L)} \times H' \times \frac{1,000 \text{ L}}{1 \text{ m}^3} \times \text{AF} \quad (13)$$

The term "AF" is an attenuation factor that describes the anticipated decrease in contaminant concentrations over time as the vapor migrates to and eventually impacts groundwater (e.g., via natural degradation, resorption to soil particles or migration into soil moisture). Approaches for

calculation of site-specific, vapor attenuation factors are not well established and beyond the scope of this technical memorandum.

LINDA LINGLE
GOVERNOR OF HAWAII

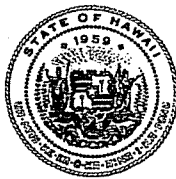

CHIYOME L. FUKINO, M.D.
DIRECTOR OF HEALTH

STATE OF HAWAII
DEPARTMENT OF HEALTH
919 Ala Moana Boulevard, Room 206
HONOLULU, HAWAII 96814

In reply, please refer to:
File: EHA/HEER Office
2007-314-RB

June 27, 2007

TO: Interested Parties

FROM: Keith E. Kawaoka, D.Env., Program Manager 
Hazard Evaluation and Emergency Response Office

Steven Chang, Chief 
Solid & Hazardous Waste Branch

SUBJECT: Long-Term Management of Petroleum-Contaminated Soil and Groundwater

Attached for your information is a technical report that presents guidance on the long-term management of petroleum-contaminated soil and groundwater. This report serves as an addendum to the Hazard Evaluation and Emergency Response (HEER) Office document *Screening For Environmental Concerns at Sites With Contaminated Soil and Groundwater* (May 2005 and updates).

If you any questions, please contact Dr. Roger Brewer of the HEER Office at 1-808-586-4238 or contact him by email at roger.brewer@doh.hawaii.gov.

Attachment

Long-Term Management of Petroleum-Contaminated Soil and Groundwater

This technical memorandum outlines procedures for long-term management of residual petroleum contamination in soil and groundwater at sites where full cleanup is not practicable. Topics discussed include:

- Revisions to *Target Contaminants of Concern* for petroleum-contaminated media;
 - Addition of naphthalene for gasoline releases;
 - Reduction of target PAHs for diesel-only releases to naphthalene and methylnaphthalenes;
 - Inclusion of methane in soil gas samples;
- Identification of specific environmental concerns in an *Environmental Hazard Assessment* (formerly referred to as an *Environmental Risk Assessment*);
- Identification of long-term management needs and preparation of an *Environmental Hazard Management Plan*;
- Need for continued Hawaii Department of Health (HDOH) oversight:
 - Remaining contamination does not exceed action levels: *No Further Action* and case closure with no long-term monitoring or management requirements;
 - Remaining contamination exceeds action levels but very limited threat to human health and the environment: *No Further Action* and case closure with no requirement for continued monitoring; management of remaining contamination in accordance with the *Environmental Hazard Management Plan* required; or
 - Remaining contamination exceeds action levels and potentially significant threat to human health and the environment: Case remains open under continued HDOH oversight but responsible party may request concurrence that further active remediation is not practicable.

An important goal of the guidance is to allow closure of “low-risk” and low-priority cases. These are cases where remaining contamination is minimal and does not pose a significant risk to human health and the environment, even though a limited area of soil or groundwater is contaminated above HDOH environmental action levels. The remaining contamination must be properly managed in accordance with the *Environmental Hazard Management Plan* prepared for the site. No further reporting requirements will be imposed, although HDOH reserves the right to reopen the case if remaining contamination is not properly managed in the future. This allows HDOH to focus its resources on high-risk and high-priority sites. Formally closing low-risk sites also assists the owner in property transactions and redevelopment (which in some cases could assist in further cleanup). Clearly documenting post-remediation site conditions and remaining environmental concerns also reduces the chance that the owner could be inappropriately included as a “responsible party” for future, unrelated releases after the property has been sold.

The guidance draws from and adds to information presented in the Hazard Evaluation and Emergency Response (HEER) and Solid & Hazardous Waste Branch (SHWB) office *Technical Guidance Manual* documents (HDOH 1997, 2000). Guidance documents prepared by the USEPA and other state agencies are also referred to. In particular, this document incorporates guidance published by the State of California in 1996 to address what they termed “low-risk” petroleum-release sites (CalEPA 1996a). California’s guidance is based on the premise that petroleum contamination does not pose a significant threat to human health and the environment

once the source of the release is stopped and gross contamination is removed from the immediate release area (irregardless of contaminant concentrations). While very practical, the discovery of extensive plumes of MTBE-contaminated groundwater from gas stations and leaking pipelines soon afterwards and the growing importance of vapor intrusion concerns reduced the usefulness of California's guidance. The guidance presented below helps address these gaps by requiring a full evaluation of potential environmental concerns and closer HDOH oversight of cases where soil and/or groundwater are contaminated with persistent and highly mobile chemicals like MTBE.

The guidance also serves as an update and addendum to the HDOH document *Screening For Environmental Concerns at Sites With Contaminated Soil and Groundwater* (HDOH 2005a). The guidance applies to both petroleum releases overseen by the HEER Office and releases overseen by the SHWB. Responsible parties with cases being overseen by the Underground Storage Tank section of the SHWB may continue to refer to action levels presented in 1995 HDOH Risk-Based Corrective Action guidance if they choose until such time that SHWB regulations pertaining to releases from underground storage tanks are updated (HDOH 2005b, regulations currently under review).

This guidance is intended to provide a starting point for discussion of possible case closure and removal from HDOH oversight. The guidance is *not* intended to represent strict requirements for closure and issuance of *No Further Action* letters to responsible parties. The information provided in this guidance will be updated as appropriate and will be included in future revisions of the HEER and SHWB *Technical Guidance Manual* documents (currently underway). Comments and suggestions are welcome and should be addressed to Roger Brewer of HDOH at roger.brewer@doh.hawaii.gov.

Overview

Responsible parties for sites where full cleanup of contaminated soil and groundwater has occurred and representative concentrations of contaminants in soil, soil gas and groundwater are below HDOH Tier 1 Environmental Action Levels (EALs) can petition HDOH for a *No Further Action* letter and case closure. Site conditions often limit the extent to which contaminated soil and groundwater can be aggressively remediated, however. This situation is especially common in heavily developed, urban areas. Excavation and removal of heavily contaminated soil and free product in the immediate area of the release is generally achievable. Concerns about building foundations, subsurface utilities and roadways coupled with high costs, however, often limit the feasibility of complete cleanup.

This guidance describes conditions where continued HDOH oversight of the site will be required (refer to Figures 1, 2 and 3). The guidance also presents conditions where a responsible party can petition for case closure under a *No Further Action* letter when contaminant concentrations exceeds Tier 1 EALs (or approved, alternative action levels) but the remaining threat to human health and the environment is minimal. When the remaining threat is still significant but further attempts to actively reduce contaminant levels via excavation, soil vapor extraction, direct groundwater treatment, etc., is not practicable, the responsible party can petition HDOH to concur that no further active remediation is required at the site. This allows current and future owners (as well as financial institutions) to better assess the monetary, environmental liability tied to the property and reduce financial uncertainty in property transfer or redevelopment plans.

Costs associated with long-term monitoring or engineered controls (caps, etc., if applicable) are, in contrast, relatively easy to project.

Continued HDOH oversight will likely be required at sites where Tier 1 EALs (or approved, alternative action levels) are exceeded *and* one or more of the following conditions exist (refer also to Figures 2 and 3):

- Sites where active remediation is still technically and economically practicable;
- A plume of contaminated groundwater is present that could threaten existing or future water supply wells;
- A plume of contaminated groundwater is present that could be acutely toxic to aquatic organisms if it discharges into a surface water body;
- Persistent chemicals such as lead, PCBs, chlorinated solvents, etc., are present above action levels for unrestricted/residential land use and no land use covenant/deed restriction in place;
- Remaining contamination poses direct-exposure and/or vapor-intrusion concerns for current and anticipated future land use in the absence of engineered controls;
- Greater than ten cubic meters of grossly contaminated soil are present within three meters of the ground surface (or above groundwater, if less than three meters deep).

Sites where each of the following conditions are met can petition for a *No Further Action* letter and case closure, provided that the remaining contamination is properly managed in accordance with the *Environmental Hazard Management Plan* prepared for the site (refer to Figures 2 and 3):

General:

- The release has been stopped and ongoing sources, including free product, have been removed or remediated to the extent practicable;
- Remaining contamination documented in an updated site assessment report, including maps that clearly define the extent and magnitude of remaining contamination above HDOH EALs (or other approved screening levels);
- Remaining environmental concerns are documented in an *Environmental Hazard Assessment* report;
- Requirements for long-term management of remaining contamination are presented in an *Environmental Hazard Management Plan*;

For soil:

- Representative concentrations of persistent chemicals do not exceed action levels (e.g., lead, PCBs, PAHs, etc.; multi-increment data preferred for surface and near surface samples, when practicable);
- Engineered controls (pavement, etc.) in place to prevent direct-exposure, vapor-intrusion or leaching concerns;
- Volume of contaminated soil within three meters (ten feet) of surface $\leq 10\text{m}^3$ (approximately 15 cubic yards);

For groundwater:

- Body of groundwater that exceeds action levels is not expanding and/or or migrating (i.e., the plume is “stable” or shrinking);
- For impacted drinking water resources:
 - Plume is not within 300m (approximately 1,000 ft) of an active water supply well and within the producing aquifer or within 150m of a surface water body that is a potential source of drinking water;
 - Persistent chemicals not present above drinking water goals (MTBE, chlorinated solvents, etc.);
 - Non-persistent, petroleum-related contaminants do not exceed drinking water goals by more than one order of magnitude;
- For plumes within 150m of an aquatic habitat (including drainage ways that lead to a surface water body):
 - Contaminant concentrations do not exceed action levels for chronic aquatic toxicity concerns for undeveloped waterfronts; or
 - Contaminant concentrations do not exceed action levels for acute aquatic toxicity concerns for developed waterfronts;
- For plumes not within 150m of an aquatic habitat:
 - Contaminant concentrations do not exceed action levels for acute aquatic toxicity concerns; and
- No vapor intrusion or methane buildup concerns in the absence of engineered controls.

The distance of 300m from a producing well to highlight “high-risk” plumes is subjective and is not necessarily reflective of groundwater flow rates in well capture zones. The two-year capture zone for municipal water wells installed in the basal, basalt aquifer can extend outward from the well head 3,000 meters or more (personal communication, HDOH Safe Drinking Water Branch). The upper few meters of the aquifer (where petroleum-contaminated groundwater is usually restricted), however, may not be included in the primary capture zone for wells that are screened well below the top of the water table. Unfortunately, detailed information on the design and construction of municipal water supply wells is not available to the general public. A more detailed evaluation will be required if HDOH determines that a water supply well is potentially at risk of being contaminated.

Sites where the above conditions are met can petition HDOH for case closure under a *No Further Action* letter. The burden and responsibility for long-term management of remaining contamination, as described in an *Environmental Hazard Management Plan*, is placed on the property owner (or other responsible party). HDOH reserves the right to reopen a case if it is determined that residual contamination is not being adequately managed.

Sites that do not meet these conditions will remain under the long-term oversight of HDOH, unless otherwise determined on a case-by-case basis. Responsible parties can, however, petition HDOH for a letter concurring that *No Further Active Remediation* is required. This lessens uncertainty regarding the financial “environmental liability” associated with the property and can assist in future property transfers and redevelopment.

Determining Need for Continued HDOH Oversight

A stepwise approach to determine the need for continued HDOH oversight of petroleum-contaminated sites is discussed below and summarized in Figures 1 through 3. Target contaminants of concern should be identified based on a comparison to HDOH Tier 1 EALs or approved, alternative action levels. The extent and magnitude of remaining petroleum contamination above action levels must be clearly documented in an updated site assessment report that summarizes post-remediation site conditions.

Potential environmental concerns posed by the contamination must be identified and discussed in an *Environmental Hazard Assessment* report. In most cases, this will involve a comparison of site data to HDOH EALs for specific environmental concerns or acceptable, alternative criteria (HDOH 2005a). A more detailed assessment of environmental concerns can be carried out on a site-by-site basis as needed.

This information should be used to develop an *Environmental Hazard Management Plan* that describes long-term monitoring and management of remaining contaminated soil and groundwater at the site. The report must discuss any engineered or institutional controls necessary to keep the contamination from spreading as well as to prevent adverse exposure of residents or workers and ensure proper reuse or disposal of soil and groundwater that is disturbed during future subsurface activities. Both the *Environmental Hazard Assessment* and *Environmental Hazard Management Plan* can be presented as part of the updated, site assessment report.

Step 1: Identify Target Contaminants of Concern

Table 1 provides an updated summary of contaminants of potential concern that must be included in environmental investigations at petroleum release sites. Petroleum contamination must be evaluated in terms of both Total Petroleum Hydrocarbon (TPH) and target "indicator chemicals" for the specific type of petroleum product released (e.g., benzene, toluene, ethylbenzene and xylenes or "BTEX", methyl tertiary butyl ether [MTBE], polynuclear aromatic hydrocarbons [PAHs], etc.). Soil, groundwater and soil gas samples must always be tested for TPH in addition to the target indicator chemicals noted in Table 1 and discussed below.

Petroleum is a complex mixture of hundreds of different compounds composed of hydrogen and carbon (i.e., "hydrocarbon" compounds). The bulk of these compounds are evaluated under the all-inclusive category of "TPH." Gasoline-range TPH is a petroleum mixture characterized by a predominance of branched alkanes and aromatic hydrocarbons with carbon ranges of C6 to C12 and lesser amounts of straight-chain alkanes, alkenes and cycloalkanes of the same carbon range (API 1994). Total Petroleum Hydrocarbon associated with middle distillates (e.g., kerosene, diesel fuel, home heating fuel, jet fuel, etc.) is characterized by a wider variety of straight, branched and cyclic alkanes, PAHs (especially naphthalenes and methyl naphthalenes) and heterocyclic compounds with carbon ranges of approximately C9 to C25. Residual fuels (e.g., Fuel Oil Nos. 4, 5, and 6, lubricating oils, mineral oil, used oils, asphalts, etc.) are characterized complex, polar PAHs, naphthoaromatics, asphaltenes and other, high-molecular-weight, saturated hydrocarbon compounds with carbon ranges that in general fall between C24 and C40.

Laboratory analysis for TPH as gasolines and middle distillates is generally carried out using gas chromatography, modified for "gasoline-range" organics ("Volatile Fuel Hydrocarbons") and "diesel-range" organics ("Extractable Fuel Hydrocarbons"), respectively (e.g., EPA Method

8015). Analysis for TPH as residual fuels up to the C40 carbon range can be carried out by gas chromatography, infrared or gravimetric methods. The latter methods are rarely used, however, due to an inability to discriminate the type of the petroleum present and interference with organic material in the soil.

Environmental action levels for TPH are developed by assigning representative fate and transport properties and toxicity factors to each TPH category and applying the same models and approaches as used for the target, indicator compounds (HDOH 2005a). A more in-depth analysis of the specific components of the TPH can be carried out in a site-specific environmental hazard assessment as needed (e.g., TPHWG 1998, MAEDP 2002).

Target indicator chemicals typically make up only a small fraction of the total petroleum present but are important players in the assessment of environmental hazards posed to human and the environment. A brief discussion of target indicator chemicals for petroleum products is included in Chapter 2 of the HDOH document *Screening For Environmental Concerns at Sites With Contaminated Soil and Groundwater* (HDOH 2005a). The 2005 HDOH guidance recommends that the following PAHs be included as target indicator chemicals for soil and groundwater contaminated with middle distillates and residual fuels:

- acenaphthene
- acenaphthylene
- anthracene
- benzo(a)anthracene
- benzo(b)fluoranthene
- benzo(g,h,i)perylene
- benzo(a)pyrene
- benzo(k)fluoranthene
- chrysene
- dibenzo(a,h)anthracene
- fluoranthene
- fluorene
- indeno(1,2,3)pyrene,
- methylnaphthalenes (1- and 2-)
- naphthalene
- phenanthrene
- pyrene

Environmental Action Levels for these chemicals are included in the HDOH EAL lookup tables (HDOH 2005a). The list of target PAHs was taken from guidance prepared by the USEPA and various state agencies in the 1990s (e.g., CalEPA 1996b, USEPA 2004).

This technical memorandum reduces the PAHs that must be included as target indicator compounds for releases of middle distillate fuels to naphthalene and methylnaphthalene (Table 1, after MAEDP 2002). A review of field data and discussions suggests that the majority of the PAHs are not present in middle distillate fuels at concentrations that would drive environmental concerns and cleanup actions. From an environmental hazard standpoint, cleanup of releases of middle distillate fuels is almost always driven by Total Petroleum Hydrocarbons (TPH) contamination, not PAHs. Naphthalene and methylnaphthalenes are two potential exceptions, since they can be present in middle distillate fuels at relatively high concentrations and are moderately volatile and mobile. Naphthalene is also an upcoming contaminant in vapor intrusion studies, although it is unlikely to be present in middle distillate fuels at levels that would pose vapor intrusion concerns when TPH itself does not exceed HDOH action levels.

Soil and groundwater contaminated with middle distillate fuels must also be tested for BTEX (Table 1). Although BTEX rarely drives cleanup for releases middle distillate fuels, their presence or absence is a useful indicator of past gasoline releases at the site or the migration of

gasoline-contaminated groundwater onto the property from offsite sources. Testing for naphthalene at gasoline release sites is also recommended (refer to Table 1).

Soil and/or groundwater contaminated with used oils, coal tar, asphalt and other heavy petroleum mixtures must be tested for the full suite of PAHs noted above. Releases of unused lube oil, transformer oils, mineral oils, virgin hydraulic oils, Fuel Oil #6 and similar products do not require testing for PAHs and other chemicals if it can be demonstrated that product released was never heated to high temperatures (potentially producing PAHs). Testing must also be carried out for volatile organic compounds (VOCs, including chlorinated solvents), PCBs and heavy metals unless otherwise justified.

Step 2: Prepare Updated Site Assessment Report

Site conditions following active remediation of contaminated soil and groundwater to the extent practicable must be clearly documented in an updated site assessment report. Information that should be provided in the report includes:

- Summary of Past, Current and Anticipated Future Site Activities and Uses:
 - Describe past and current site uses and activities;
 - Describe foreseeable future site uses and activities;
- Summary of Pre- and Post-Remediation Site Conditions:
 - Identify all types of impacted media;
 - Identify all sources of chemical releases;
 - Identify all chemicals of concern;
 - Delineate on to-scale maps the magnitude and extent of contamination above EALs (or other approved action levels) to extent practicable and applicable;
 - Identify nearby groundwater extraction wells, bodies of surface water and other potentially sensitive ecological habitats;
 - Ensure data are representative of site conditions.

Surveyed, to-scale maps of the site that clearly indicate the location of remaining contaminated soil and groundwater must be included in the report. This information will be necessary for both the assessment of potential environmental concerns or *hazards* posed by the contamination as well as the preparation of an *Environmental Hazard Management Report*, discussed in the following steps.

Step 3: Prepare Environmental Hazard Assessment

An *Environmental Hazard Assessment* is an evaluation of potential environmental concerns at sites where releases of petroleum or other hazardous chemicals have occurred (HDOH 2005a). Common environmental concerns that must be assessed at sites where petroleum-contaminated soil and/or groundwater are identified include:

Soil:

- Direct exposure to contaminants in soil (ingestion, dermal absorption, inhalation of vapors and dust in outdoor air);

- Emission of vapors to building interiors;
- Impacts to terrestrial ecological habitats;
- Leaching and impacts to groundwater resources; and
- General gross contamination and resource degradation (including generation of vapors and explosive hazards, potentially mobile free product, odors, general resource degradation, etc.);

Groundwater:

- Impacts to drinking water resources;
- Emission of vapors to building interiors;
- Impacts to aquatic habitats (discharges of contaminated groundwater to surface water); and
- Other gross contamination and resource degradation concerns (including intrusion of vapors into utility conduits, potentially mobile free product, sheens, etc.).

A more detailed discussion of common environmental concerns posed by contaminated soil and groundwater is provided in the HDOH document *Screening For Environmental Concerns at Sites With Contaminated Soil and Groundwater* (HDOH 2005a).

The presence or absence of potential environmental concerns is first evaluated in a brief, *Environmental Hazard Assessment*. This can be done by comparison of site data to the summary, Tier 1 EALs presented in Volume 1 of the HDOH document *Screening For Environmental Concerns at Sites With Contaminated Soil and Groundwater* (HDOH 2005a). The presence of chemicals at concentrations above an action level *does not* necessarily indicate that hazardous conditions exist at the site. It *does*, however, indicate that additional evaluation of identified, potential concerns is warranted.

When a Tier 1 EAL (or approved, alternative action level) is exceeded, specific environmental concerns can be identified by comparison of representative contaminant concentrations to detailed action levels presented in Appendix 1 of the HDOH EAL document. The Excel-based, EAL “Surfer” or electronic lookup tables can be used to expedite this process (available for download from the HDOH EAL webpage, see URL address in HDOH 2005a reference). The Surfer allows direct input of representative contaminant concentrations. Specific environmental concerns are identified if input contaminant concentrations in soil or groundwater exceed the primary Tier 1 EAL. The Surfer then generates a “Summary Report” that can be printed and included as supporting documentation for a basic *Environmental Hazard Assessment* report. Note that decision unit and multi-increment investigation strategies are preferred over the use of discrete sample data, when feasible (refer to HDOH 2007b).

An *Environmental Hazard Assessment* report must be prepared to document potential environmental concerns associated with remaining contamination at the site. This document should include the following information:

- Site Background;
- Summary of investigations (including to-scale maps with a north arrow);
- Applicability of HDOH EALs or alternative action levels;
- Selection of soil and groundwater categories;

- Selection of EALs & comparison to site data;
- Identification of specific environmental concerns if final Tier 1 EALs exceeded; and
- Recommendations for followup actions, including preparation of an *Environmental Hazard Management Plan* or, if needed, a more detailed assessment of identified environmental concerns.

A more detailed discussion of the preparation of *Environmental Hazard Assessment Reports* is provided in Volume 1 of the HDOH EAL document (HDOH 2005a). For relatively simple sites, the assessment can be included as a separate chapter in the post-remediation report, with EAL Surfer printouts, etc., included in the appendices. Maps that depict specific environmental concerns posed by contamination in various areas of the site can also be very useful, and in some cases required, for inclusion in the site *Environmental Hazard Management Report*, as discussed below (e.g., areas that pose direct-exposure, leaching or vapor intrusion concerns; areas of free product, grossly contaminated soil or methane buildup, etc.).

Conditions that pose immediate or short-term environmental concerns should be addressed as quickly as possible. This includes exposure of residents or workers to potentially harmful levels of contaminants in soil (“direct exposure”), impacts to water supply wells, intrusion of vapors or methane into overlying structures (including explosive hazards) and discharges of free product to surface water.

Note that the approach described above is referred to as *Environmental “Risk” Assessment* in the 2005 HDOH EAL document. The term “risk” is replaced with the term “hazard” in this guidance document. This was done to emphasize the fact that some environmental concerns are not necessarily toxicological in nature, as the term “risk” is often interpreted to indicate. Examples include explosive hazards, leaching of contaminants from soil and even general gross contamination concerns. Human health and ecological risk are of course an important component of an *Environmental Hazard Assessment*, but they cannot be used as stand-alone tools to assess the need for potential cleanup actions at sites where petroleum-contaminated soil and groundwater are identified. This change in terminology will be noted in upcoming revisions of HDOH environmental guidance documents.

Step 4: Prepare Environmental Hazard Management Plan

The purpose of an *Environmental Hazard Management Plan* (EHMP) is threefold: 1) document the extent and magnitude of contaminated soil and groundwater left in place at a site, 2) summarize identified environmental concerns posed by the contamination and 3) provide a framework for long-term management of the contamination. An EHMP must be prepared for all petroleum-release sites where residual soil and groundwater contamination is left in place above levels that could pose potential environmental concerns. A copy of the plan must be submitted to HDOH for inclusion in the public file.

An *Environmental Hazard Management Plan* is similar in intent to what are commonly referred to as *Risk Management Plans* or *Soil and Groundwater Management Plans*, as described in the current editions of the HEER Office and SHWB *Technical Guidance Manuals* (HDOH 1997, 2000; USEPA 2003). A *Risk Management Plan* or *Exposure Prevention Management Plan* typically focuses on the reduction or elimination of risks to human health posed by direct exposure to contamination in soil or groundwater or by the emission of vapors into buildings.

While important, other potential concerns such as leaching, explosive hazards and the simple need to properly manage grossly contaminated soil or groundwater are often ignored. A *Soil and Groundwater Management Plan* describes measures for handling, reusing and/or disposing of contaminated soil and groundwater that is encountered during future subsurface activities, including the repair of underground utilities or redevelopment of the property. Again, this information is important but these plans often fail to identify the specific environmental concerns posed by the contamination.

An *Environmental Hazard Management Plan* combines all necessary information into a single, stand-alone document that identifies the nature of the contamination present, the potential environmental concerns posed by the contamination, and appropriate measures to ensure that these concerns are adequately addressed. An *Environmental Hazard Management Plan* should include the following information, at a minimum:

- Brief summary of the site background and history of contaminant releases;
- Identification of specific contaminants of concern, including TPH, “Target Indicator Compounds” and any other contaminants associated with the release (refer to Step 1);
- Clear depiction of the extent and magnitude of remaining contamination in soil, groundwater and/or soil gas, presented on easily readable, to-scale maps with a north arrow (refer to Step 2);
- Identification and discussion of all potential environmental concerns (refer to Step 3);
- Requirements for long-term monitoring of contaminants in soil, groundwater, and/or soil gas;
- Discussion of engineered and/or institutional controls needed to address identified environmental concerns, including caps, barriers, etc., needed to eliminate exposure pathways;
- Guidance on the proper handling, reuse and disposal of contaminated soil and/or groundwater that is encountered during future site activities;
- Measures for repair or replacement of engineered controls that are disturbed or breached during future site activities; and
- Any other information required to adequately mitigate and manage remaining environmental concerns at the site.

A brief Fact Sheet that summarizes key elements of the *Environmental Hazard Management Plan* in simple, non-technical terms will be required for large, complex sites where significant public review is anticipated.

Long-term environmental concerns must be clearly assessed and documented to ensure that in-place management of the remaining petroleum contamination is viable and carried out properly. Examples of potential, long-term management actions include: 1) capping of grossly contaminated soil under paved areas or buildings, 2) installation of vapor barriers beneath buildings, 3) lining of utility corridors to prevent the migration of contaminated groundwater or vapors into storm drains, utility trenches or other subsurface conduits, 4) restrictions on subsurface activity in some areas without pre-approved work plans, 5) procedures for proper disposal or reuse of contaminated soil and groundwater disturbed during subsurface activities, 6) long-term monitoring of on-site groundwater and soil gas and, 7) installation of offsite “sentinel

wells” to monitor potential long-term impacts to more distant water supply wells or surface water bodies.

Additional guidance on engineered and institutional controls and the preparation of *Environmental Hazard Management Plans* will be provided in the upcoming revision of the HEER Office *Technical Guidance Manual* (anticipated late 2007, refer also to USEPA 2003). The complexity of the *Environmental Hazard Management Plan* for a given site will depend on the extent and nature of the specific contaminants released (mobility, toxicity, explosive hazard, etc.), the specific environmental concerns posed by the contamination and the current and future site use. For relatively simple sites, the *Environmental Hazard Management Plan* can be included as an appendix in the final site closure report.

Step 5: Determine Need for Continued HDOH Oversight

Figures 2 and Figure 3 provide flow charts to assist in determining an appropriate course of action for long-term oversight of petroleum-contaminated soil and groundwater, respectively. The flow charts, and related discussion below, should be considered general guidance only and not strict requirements that must be met before the status of a site can be updated to “closed” under a *No Further Action Letter*. As in any subject where the distinct lines between “yes” and “no” are difficult to draw, the use of sound, professional judgment is very important.

Cases where remaining contamination is minimal in extent and/or magnitude and not likely to pose significant environmental concerns under worst-case conditions can generally be closed under a *No Further Action* letter from HDOH. No further monitoring or reporting requirements will be imposed on these sites. Long-term management of remaining contamination must be carried out in accordance with the *Environmental Hazard Management Plan* prepared for the site. HDOH retains the right to reopen the case and impose enforcement actions if contaminated soil or groundwater is not properly managed.

Continued HDOH oversight will be necessary at sites where remaining contamination could pose significant environmental concerns if not appropriately managed. Sites where potentially significant, environmental concerns remain but active remediation (excavation, soil vapor extraction, etc.) is no longer practical can, and should, request a letter from HDOH clarifying that no *further active remediation* is required. The need for ongoing groundwater or in some cases soil gas monitoring should also be evaluated. The letter is intended to clarify that all major cleanup actions have been completed at the site and that the site has moved into a status of long-term monitoring and management. These letters help property owners, financial institutions and potential purchasers establish the “environmental liability” associated with the remaining environmental contamination and can greatly assist in future property transactions and redevelopment. The *Environmental Hazard Management Plan* should include a description of conditions that will need to be met before the case can be formally closed and a no further action letter issued.

Long-Term Oversight of Petroleum-Contaminated Soil

Continued HDOH oversight of cases with residual petroleum contamination in soil will be required if one of more of the following conditions exists and sufficient justification to close the case is not otherwise provided (see Figure 2):

- Additional remediation technically and economically practicable;
- Anticipated residential redevelopment in near future and representative contaminant concentrations exceed action levels for unrestricted land use;
- Persistent contaminants present above direct-exposure or vapor intrusion action levels for unrestricted land use and no deed restriction recorded (PAHs, MTBE, heavy metals, PCBs, chlorinated solvents, etc.);
- Direct exposure, vapor intrusion and/or leaching concerns under current or anticipated land use but engineered controls not in place prevent exposure or contaminant migration; and/or
- Nonpersistent contaminants only (e.g., TPH, BTEX, etc.) but volume of soil contaminated above action levels exceeds 10 cubic meters (approximately 15 cubic yards).

HDOH Tier 1 EALs are pre-approved for use at all sites and should be referred to in the absence of acceptable, site-specific, Tier 2 or Tier 3 action levels (refer to HDOH EAL document, HDOH 2005a).

For the purposes of this guidance, the term “soil” refers to any unconsolidated soil, sediment or fill material. HDOH Environmental action levels for soil are primarily intended for comparison with sample data collected above the water table. This is because residents, as well as commercial and industrial workers, are unlikely to come into regular contact with soil below the water table. The EALs also include consideration of vapor intrusion concerns and leaching concerns, both of which should not be applied to soils situated in groundwater. Direct collection of groundwater data is instead more pertinent to evaluate these concerns. The collection of soil sample data below the water table can sometimes assist in developing long-term management strategies for sites where residual contamination is to be left in place, however. Procedures for management of contaminated soil situated at or below the water table that is disturbed during future subsurface activities should also be included in the site *Environmental Hazard Management Plan*. Formal covenants that restrict land use and implement engineered controls to prevent exposure or leaching are required for sites where representative concentrations of persistent chemicals exceed action levels for unrestricted, residential land use.

Multi-increment sample data are preferred to establish representative contaminant concentrations within designated decision units over discrete sample data, although in practice this approach is most applicable for surface samples to be tested for non-volatile contaminants. The State of Alaska recently published guidance on the collection of multi-increment samples that area to be tested for volatile chemicals (ADEC 2007). The approach calls for the placement of soil increments in methanol in the field. Restrictions on airline transportation of methanol may limit the use of this approach in Hawai‘i, however. Additional guidance on this subject to be presented in the upcoming update of the HEER Office *Technical Guidance Manual* (anticipated Fall 2007).

Soil gas data are preferred over soil data for evaluation of potential vapor intrusion concerns. Leaching concerns should be evaluated based on comparison to HDOH action levels, the results of laboratory batch test (HDOH 2007a) and/or groundwater monitoring data for sites where the contaminated soil is not capped or in direct contact with groundwater. Closure of a case under a *No Further Action* letter with deeper, grossly contaminated soil that exceeds ten cubic meters in

volume is acceptable provided that the soil does not pose significant leaching and groundwater contamination concerns. This should be discussed on a case-by-case basis with HDOH.

Gross contamination action levels for soil address odor and aesthetic concerns and resource degradation in general (refer to Volume 1 of the HDOH EAL document). The action levels also help identify soil with mobile free product or explosive levels of vapors. Remaining gross contamination concerns at sites where active soil cleanup is no longer practicable should be evaluated by an inspection of soils that exceed action levels for TPH. Gross contamination action levels for soils contaminated with gasoline and middle distillate fuels (diesel, jet fuel, etc.) are based to a large degree on field experience. Action levels for shallow soils ($\leq 3\text{m}$) are considered to be relatively accurate for odor concerns in a residential land use scenario (100 mg/kg and 500 mg/kg for gasoline and middle distillate fuels, respectively, refer to Appendix 1 of the HDOH EAL document for commercial/industrial action levels). Action levels for deeper soils are useful to identify the presence of potentially mobile, free product or the production of potentially explosive petroleum or methane vapors (2,000 mg/kg and 5,000 mg/kg, respectively).

Gross contamination action levels for the broad category of TPH “residual fuels” (motor oil, mineral oil, grease, etc.) are significantly more flexible. Used oil could in some cases pose nuisance concerns at concentrations as low as the default residential action level of 500 mg/kg for residual fuels but higher levels are acceptable on a case-by-case basis if it can be adequately demonstrated that the contamination does not pose adverse nuisance conditions. An in-house study using spiked soil samples indicated action levels of 5,000 mg/kg (shallow soils) and 25,000 mg/kg (deep soils) are appropriate for mineral oil (commonly used in electrical transformers), provided that the oil has not been heated to high temperatures, subjected to fire or contaminated with other chemicals. Similar gross contamination action levels may be appropriate for heavy greases.

Long-Term Oversight of Petroleum-Contaminated Groundwater

Continued HDOH oversight of cases with residual petroleum contamination in groundwater will be required if one of more of the following conditions exists and sufficient justification to close the case is not otherwise provided (see Figure 3):

- The area of the plume that exceeds action levels is still expanding and/or or migrating away from the original release area;
- The plume is within the capture zone of an active water supply well or within 150m of a potable surface water body and contaminant levels exceed drinking water action levels;
- The plume is not within the capture zone of an active supply well but within a potential drinking water aquifer and concentrations of TPH, BTEX and related petroleum compounds exceed action levels by an order of magnitude or more;
- The plume is not within the capture zone of an active supply well but within a potential drinking water aquifer and concentrations of MTBE, chlorinated solvents or other persistent compounds exceed action levels;
- The plume is within the capture zone of a nondrinking water, industrial or irrigation supply well and contaminant levels exceed action levels for impacts to surface water bodies or other environmental concerns;
- The plume is within 150m of an undeveloped water front or sensitive aquatic habitat and contaminants exceed action levels for chronic toxicity to aquatic organisms;

- The plume is within 150m of a highly developed waterfront area (e.g., wharf area) and contaminants exceed action levels for acute toxicity to aquatic organisms or potentially mobile free product is present;
- Storm sewers, abandoned pipelines or other subsurface utilities are located adjacent to or within plume and could serve as potential conduits for migration of free product or other contaminants to surface water bodies above the levels of concern noted above; and
- Free product on groundwater could pose a risk to on-site workers involved in excavation or dewatering activities, and/or long-term methane generation or vapor intrusion concerns.

A more detailed discussion of groundwater utility (e.g., drinking water supply, irrigation supply, etc.) is provided in Volume 1 of the HDOH document *Screening For Environmental Concerns at Sites With Contaminated Soil and Groundwater* (HDOH 2005a). The status of an aquifer as a potential source of drinking water is determined in part on the location of the groundwater with respect to the Underground Injection Control (UIC) Line and the state *Aquifer Identification and Classification* technical reports prepared by the University of Hawai'i. Groundwater in a viable aquifer that is situated inland ("mauka") of the UIC line or in the basal aquifer under coastal caprock sediments is generally considered by HDOH to be a potential water supply resource.

Once the source of a release has been removed (including vadose-zone soil that could act as a secondary leaching source), a minimum of two years of quarterly monitoring is generally required to establish that a plume is not expanding or migrating above levels of potential concern. This assumes that groundwater is not contaminated with MTBE and other persistent chemicals above levels of concern, in which case a plume may never become truly "stable" and long-term monitoring will be required. Long-term monitoring data can also be used to develop degradation trends for contaminants of concern (e.g., API 2007). If a convincing case can be made that contaminant levels will reach target goals within five years and currently used water supply wells are not threatened then closure of the case under a *No Further Action* letter will be considered.

If the source(s) of groundwater contamination has been gone for five or more years earlier, less data, in some cases even a single monitoring event, will be adequate to establish that a plume has reached it's greatest extent and is unlikely to spread further. Natural degradation and sorption of remaining contamination to soil particles quickly halt the spread and migration of petroleum-contaminated groundwater once the source has been removed. Plumes rarely extend more than 150 meters from the original release area in the absence of MTBE or other persistent and highly mobile chemicals. However, storm sewers, abandoned pipelines, other subsurface utilities or shallow irrigation wells could act as conduits for contaminated groundwater to reach more distant surface water bodies. Potential dewatering at construction sites must also be considered in areas of shallow groundwater, as should the potential for contaminated groundwater to enter an irrigation or industrial water supply well and ultimately be discharged into an irrigation canal, storm water drain or other direct conduit to a surface water body. These situations will require that the groundwater be screened against chronic rather than acute aquatic toxicity goals and must be evaluated on a site-by-site basis. HDOH NPDES requirements may also apply for surface discharges of contaminated groundwater.

Dilution of contaminated groundwater upon discharge to a surface water body is not taken into consideration for initial screening of potential impacts to aquatic habitats. This is because organisms living in the sediment that organisms living in the water column rely on as a food source could be exposed directly to the groundwater prior to discharge. Benthic habitats located along natural stream or channel banks or shoreline areas are particularly at risk. Groundwater in these areas should be screened against the more stringent, chronic, aquatic toxicity action levels included in Tier 1 EALs for areas within 150m of a surface water body (refer to Appendix 1 of the HDOH EAL document). Screening of groundwater data against acute aquatic toxicity action levels is considered adequate in highly developed waterfront areas (wharfs, seawalls, etc.) where significant benthic communities are generally absent in the area where contaminated groundwater may discharge and the primary risk is to aquatic organisms living in the water column. Impacts that result in a sheen on a surface water body must be avoided in all cases.

Other factors that can be considered in evaluating the need for continued HDOH oversight include the aerial extent of impacted groundwater and impacts to deep, non-potable groundwater. In commercial/industrial areas, petroleum-contaminated groundwater generally does not pose a significant threat to human health and the environment regardless of the actual concentrations of TPH or petroleum-related target indicator chemicals if the following conditions are met: 1) plume is not expanding or migrating away from the release area above final, target action levels, 2) area of remaining free product is less than approximately 100 square meters (assumed size of an existing or future building, minimal vapor intrusion and methane buildup concerns,) and 3) depth to groundwater is greater than five meters (unlikely to be encountered during future construction activity). This assumes the absence of conduits for offsite migration (storm sewers, etc.). Closure of such cases under a *No Further Action* letter with management of remaining contamination under an *Environmental Hazard Management Plan* should be considered. The primary concerns for deep (e.g., >5m), non-potable groundwater impacted with petroleum are offsite migration, the generation of methane and vapor intrusion into existing or future buildings. Closure of the case under *No Further Action* letter should be considered regardless of contaminant concentrations in groundwater if long-term groundwater monitoring data indicate that the plume is not migrating away from the release area above levels of concern and soil gas data rule out the potential for significant methane buildup or vapor intrusion concerns.

Wells that will no longer be used to monitor groundwater must be properly abandoned. Documentation on well abandonment must be submitted to HDOH for inclusion in the public file.

References:

- ADEC, 2007, *Guidance on Multi-Increment Soil Sampling* (March 2007): Alaska Department of Environmental Conservation, Division of Spill Prevention and Response, Contaminated Sites Program, http://www.dec.state.ak.us/SPAR/csp/guidance/multi_increment.pdf
- API, 1994, *Transport and Fate of Non-BTEX Petroleum Chemicals in Soils and Groundwater*: American Petroleum Institute, Health and Environmental Sciences Department, Publication No. 4593.
- API, 2007, *Technical Protocol for Evaluating the Natural Attenuation of MtBE*: American Petroleum Institute, Regulatory and Scientific Affairs Department, Publication No. 4761, http://www.api.org/ehs/groundwater/oxygenates/upload/4761_Final.pdf.

- CalEPA, 1996a, *Interim Guidance on Required Cleanup at Low Risk Fuel Sites*: California Department of Environmental Protection, California Regional Water Quality Control Board, San Francisco Bay Region, January 5, 1996.
- CalEPA, 1996b, *Supplemental Guidance For Human Health Multimedia Risk Assessments of Hazardous Waste Sites and Permitted Facilities*: California Department of Environmental Protection, Department of Toxics Substances Control, August 1996, www.dtsc.ca.gov/ScienceTechnology/index.html.
- HDOH, 1997, *Technical Guidance Manual For Implementation of the State Contingency Plan* (October 1997): Hawai'i Department of Health, Hazard Evaluation and Emergency Response Office, <http://www.hawaii.gov/health/environmental/hazard/index.html>.
- HDOH, 2000, *Technical Guidance Manual For Underground Storage Tank Closure and Release Response* (March 2000): State of Hawai'i, Department of Health, Environmental Management Division, Solid and Hazardous Waste Branch, <http://www.hawaii.gov/health/environmental/waste/ust/index.html>
- HDOH, 2005a, *Screening For Environmental Concerns at Sites With Contaminated Soil and Groundwater* (May 2005 and updates): Hawai'i Department of Health, Hazard Evaluation and Emergency Response Office, www.hawaii.gov/health/environmental/hazard/eal2005.html.
- HDOH, 2005b, *Use of May 2005 Environmental Action Levels ("EALs") at Leaking Underground Storage Tank Sites* (June 7, 2005): Hawai'i Department of Health, Solid & Hazardous Waste Branch, <http://www.hawaii.gov/health/environmental/waste/ust/index.html>.
- HDOH, 2007a, *Use of laboratory batch tests to evaluate potential leaching of contaminants from soil* (April 12, 2007): Hawai'i Department of Health, Solid & Hazardous Waste Branch, www.hawaii.gov/health/environmental/hazard/eal2005.html.
- HDOH, 2007b, *Pesticides in former agricultural lands and related areas - Updates on investigation and assessment* (May 11, 2007): Hawai'i Department of Health, Solid & Hazardous Waste Branch, www.hawaii.gov/health/environmental/hazard/eal2005.html.
- MADEP, 2002, *Characterizing Risks Posed by Petroleum Contaminated Sites* (October 2002): Massachusetts Department of Environmental Protection, Policy #WSC-02-411, http://mass.gov/dep/cleanup/laws/vph_eph.htm.
- TPHCWG, 1998, *Analysis of Petroleum Hydrocarbons in Environmental Media*: Total Petroleum Hydrocarbon Working Group (ed. Wade Weisman), Amherst Scientific Publishers, Amherst, Massachusetts, ISBN 1-884-940-14-5, <http://aehs.com/publications/catalog/contents/tph.htm>.
- USEPA, 2003, *Institutional Controls: A Guide to Implementing, Monitoring, and Enforcing Institutional Controls at Superfund, Brownfields, Federal Facility, UST and RCRA Corrective Action Cleanups* (Draft December 2002): US Environmental Protection Agency, Office of Solid Waste and Emergency Response, <http://www.epa.gov/superfund/action/ic/guide/icdraft.pdf>

Table 1. Recommended Target Analyte List For Petroleum Products

Petroleum Product	Media	Recommended Target Analytes
Gasolines	Soil	TPH, benzene, toluene, ethylbenzene, xylenes (BTEX), naphthalene, MTBE and appropriate additives and breakdown products (e.g., DBA, TBA, lead, etc.)
	Soil Gas	Same as soil plus methane
	Groundwater	Same as soil
Middle Distillates (diesel, kerosene, stoddard solvent, heating fuels, jet fuel, etc.)	Soil	TPH, BTEX, naphthalene, methylnaphthalenes (total 1- and 2-)
	Soil Gas	Same as soil plus methane
	Groundwater	Same as soil
Residual Fuels (lube oils, hydraulic oils, mineral oils, transformer oils, Fuel Oil #6/Bunker C, waste oil, etc.)	Soil	TPH, *VOCs, naphthalene, methylnaphthalenes plus remaining 15 priority pollutant PAHs, plus PCBs and heavy metals unless otherwise justified
	Soil Gas	TPH, VOCs, naphthalene, methylnaphthalenes, methane
	Groundwater	same as soil

*VOC: Volatile Organic Compounds, including BTEX and chlorinated solvent compounds

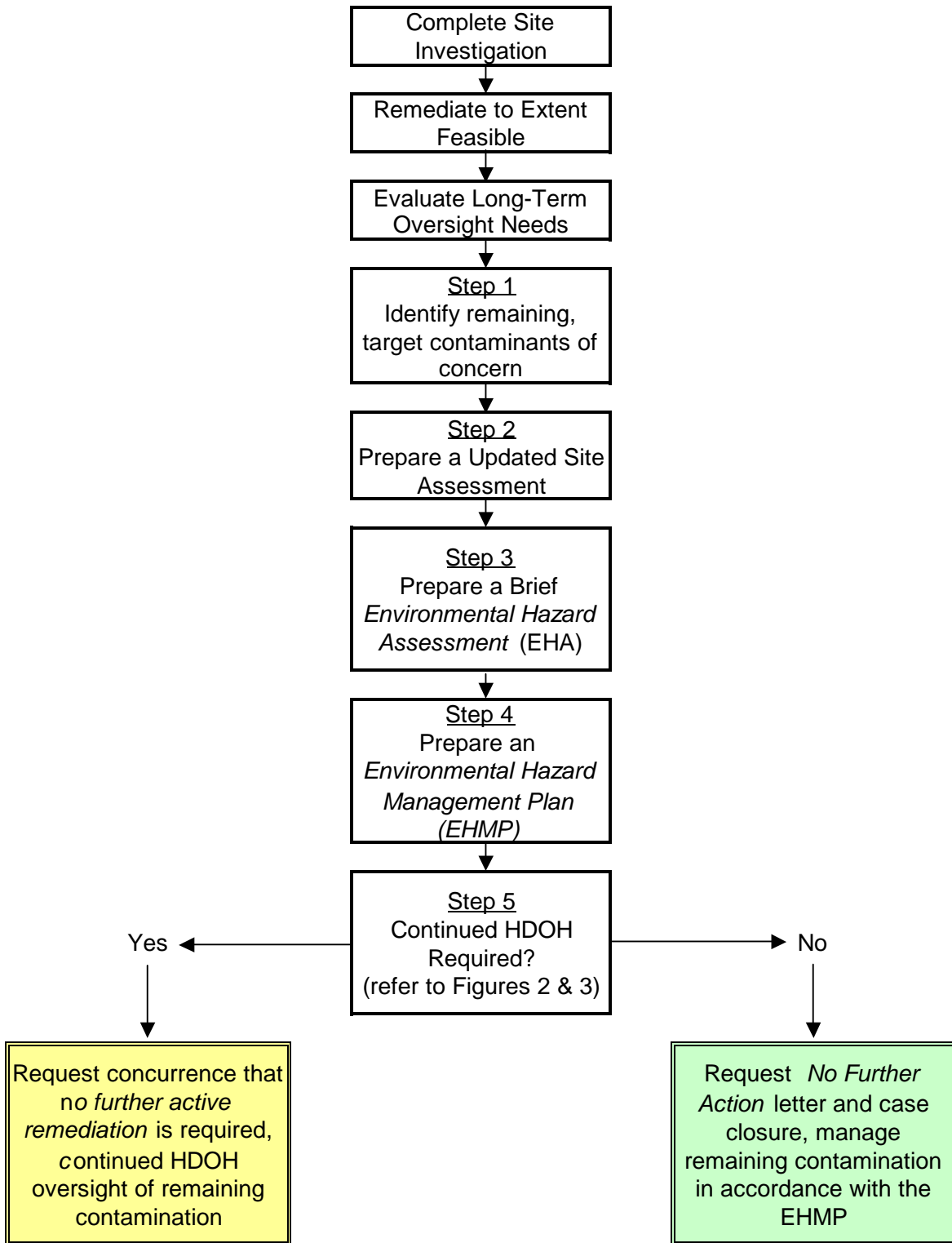

Figure 1. Overview of procedure to determine need for continued, HDOH oversight at sites with remaining petroleum contamination in soil or groundwater above HDOH EALs (or other approved action levels).

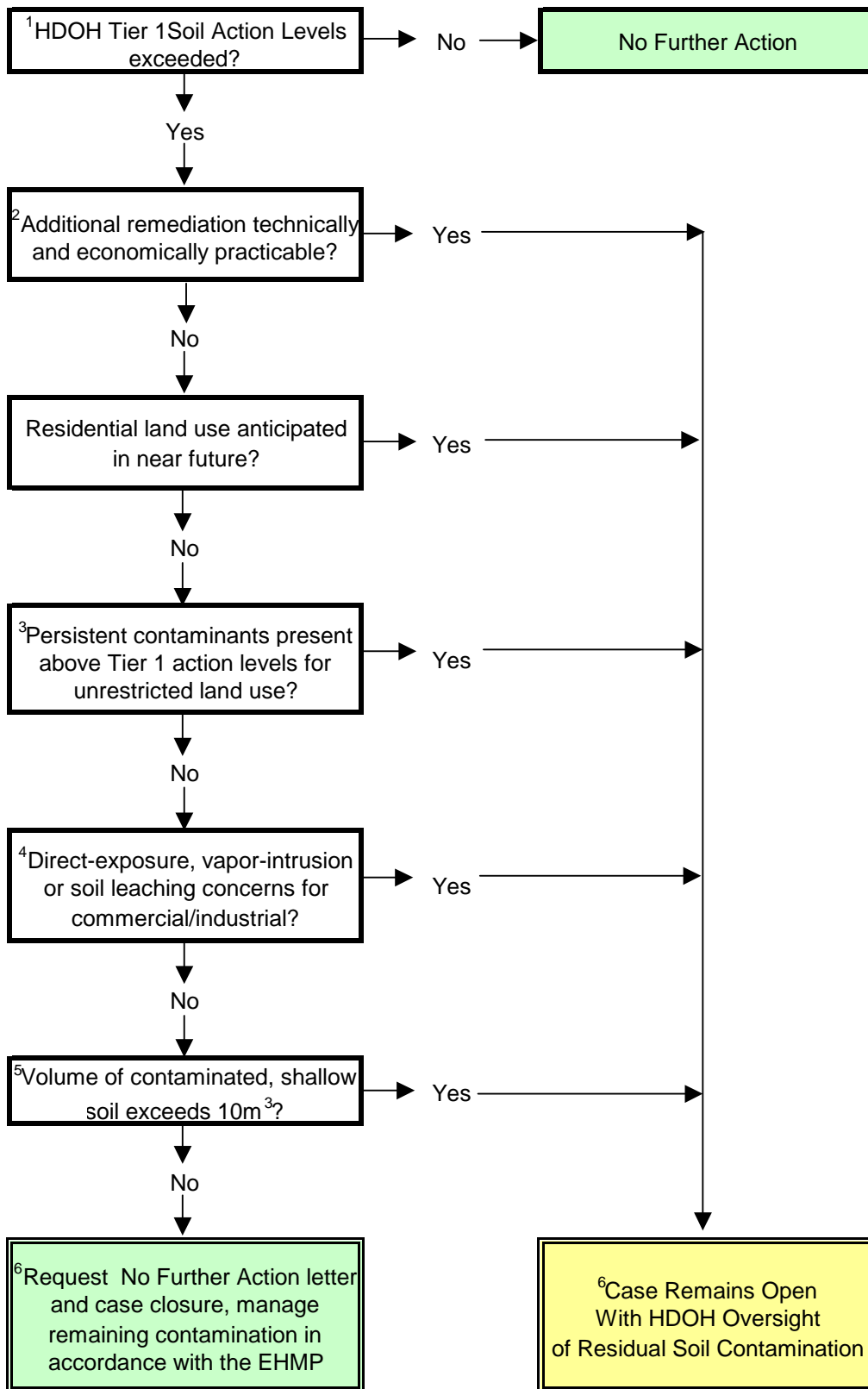

Figure 2. Decision path for long-term oversight of petroleum-contaminated soil following active remediation to extent practicable.

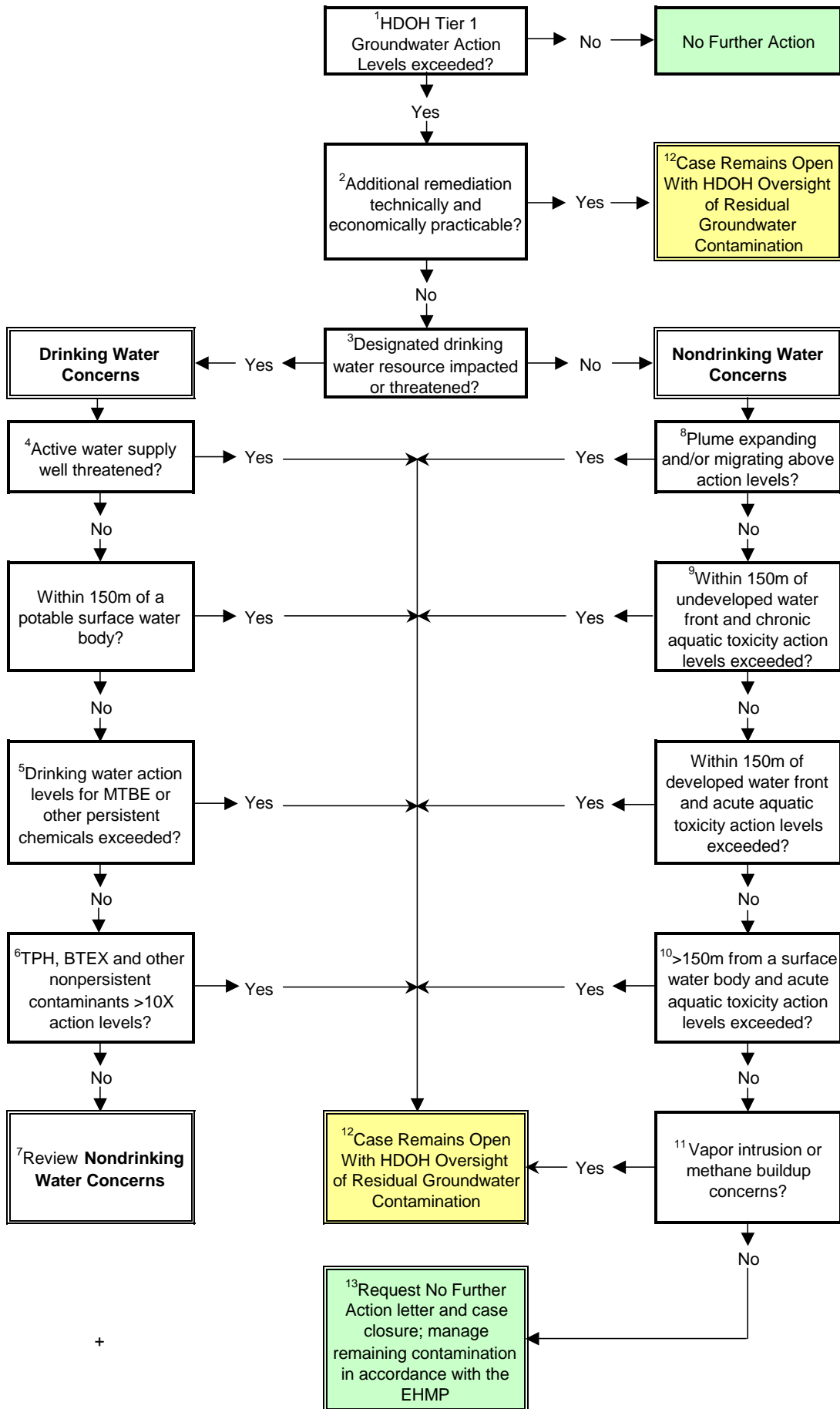

Figure 3. Decision path for long-term oversight of petroleum-contaminated groundwater following active remediation to extent practicable.

Figure footnotes

Figure 2 – Residual soil contamination:

1. Based on comparison of representative contaminant concentrations to HDOH Tier 1 EALs or approved, alternative action levels. “Soil” refers to any unconsolidated media situated above groundwater and does not include soil in the capillary fringe zone or in a smear zone associated with a fluxuating water table. Use groundwater data to evaluate potential concerns posed by soils situated below water table or within capillary fringe zone or groundwater smear zone.
2. Technical and economic practicability of additional cleanup should be discussed with HODH on a case-by-case basis.
3. MTBE, heavy metals, PCBs, chlorinated solvents, etc.
4. Commercial/industrial HDOH EALs for direct-exposure, vapor-intrusion exceeded and/or action levels for leaching concerns exceeded (or approved, alternative action levels) and engineered controls (pavement, etc.) not adequate to prevent exposure or leaching.
5. Shallow soils defined as soils within three meters (approximately ten feet) of the ground surface (HDOH 2005a). Closure of cases with greater volumes of contaminated soil left in place possible is based on a case-by-case review with HDOH.
6. No Further Action. Submittal of updated site assessment, *Environmental Hazard Assessment* and *Environmental Hazard Management Plan* required. Manage remaining contamination in accordance with the *EHMP*.
7. Case remains open under HDOH oversight. Submittal of updated site assessment, *Environmental Hazard Assessment* and *Environmental Hazard Management Plan* required. Option to petition HDOH for *No Further Remedial Action Required* letter.

Figure 3 – Residual groundwater contamination:

1. Based on comparison of representative contaminant concentrations to HDOH Tier 1 EALs or approved, alternative action levels.
2. Technical and economic practicability of additional cleanup should be discussed with HODH on a case-by-case basis.
3. Inland of UIC line or based on published groundwater resource reports.
4. Plume is within 1,000 feet in the upgradient direction of an active, producing water supply well and within producing aquifer (closer review of the potential threat to water supply wells may be required on a case-by-case basis).
5. Contaminants such as MTBE and chlorinated solvents that are known to degrade very slowly in the environment under natural conditions. Contaminant level as exhibited by current monitoring data or projected five-year degradation curve.
6. Contaminants such as TPH and BTEX that are known to rapidly degrade in the environment under natural conditions.
7. Refer to decision pathway for potential environmental concerns not directly related to drinking water.
8. Plume expanding and/or migrating above action levels, includes potential offsite migration via storm sewers, utility corridors, etc.
9. Within 150m of a sensitive aquatic habitat, generally including streams and shoreline areas that have not been significantly altered by culverts, shoreline development, etc., or otherwise protected habitat areas.
10. Consider No Further Action regardless of contaminant concentrations if plume is not migrating, area of remaining free product <100m², no vapor intrusion or methane buildup concerns and depth to groundwater is greater than five meters (see text).
11. Vapor intrusion or methane buildup concerns in the absence of engineered controls.
12. Case remains open under HDOH oversight. Submittal of updated site assessment, *Environmental Hazard Assessment* and *Environmental Hazard Management Plan* required. Option to petition HDOH for *No Further Remedial Action Required* letter.
13. Case closed. Submittal of summary report, *Environmental Hazard Assessment* and *Environmental Hazard Management Plan* required. No further monitoring required. Manage remaining contamination in accordance with the *EHMP*.

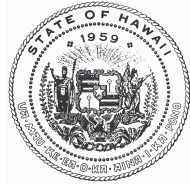

STATE OF HAWAII
DEPARTMENT OF HEALTH
P. O. BOX 3378
HONOLULU, HI 96801-3378

In reply, please refer to:
File: EHA/HEER Office

TO: Michael Miyahira
Safe Drinking Water Branch 2011-649-RB

FROM: Roger Brewer, PhD and Barbara Brooks, PhD
Environmental Hazard Evaluation
HEER Office

Through: Keith E. Kawaoka, D.Env., Program Manager
Hazard Evaluation and Emergency Response Office

DATE: January 12, 2011 (revised 2/7/11 to reflect USEPA MCL model for noncancer action levels, reduced from 33 ug/L to 20 ug/L an 11/7/11 to reflect additional groundwater data)

SUBJECT: Overview of drinking water action levels for Chromium VI

Summary

This technical memorandum presents a range of risk-based action levels for hexavalent chromium (Cr VI) in drinking water, based on published guidance and toxicity studies. The current, Maximum Contamination Level (MCL) for Total Chromium in drinking water promulgated in Hawai'i Department of Health (HDOH) regulations is 100 µg/L, equal to the MCL published by the USEPA. The Total Chromium MCL is based on an assumption that 100% of the chromium is Cr VI.

It is anticipated that the USEPA will eventually tighten drinking water standards for Total Chromium to address updated toxicity reviews of noncancer and cancer health risks posed by Chromium VI. A summary of potential risk-based action levels for Cr VI in drinking water based on the most recent, published and draft USEPA guidance is as follows:

Target Health Effect	Cr VI Drinking Water Action Levels	Notes
*Cancer Risks:	0.043 to 4.3 µg/L	Linear extrapolation model employed for cancer slope factor carries significant uncertainty for exposures below the current Total Chromium MCL.
Noncancer Risk	20 µg/L	Confidence in the toxicity factor used to derive the action level is medium to high.
Combined Range:	0.043 to 20 µg/L	Lower-bound and upper-bound range of risk-based action levels for Cr VI in drinking water based on current and draft USEPA

	guidelines.
--	-------------

*Reflects USEPA acceptable cancer risk range of 10^{-4} to 10^{-6} , include ten-fold safety factor for early life exposure.

The action levels presented above are intended to assist in the evaluation of Cr VI data for groundwater and tapwater samples to be collected by the Honolulu City and Country Board of Water Supply, as well as general groundwater investigations overseen by the Hazard Evaluation and Emergency Response (HEER) office of HDOH. **The action levels are specifically *not* intended to serve as a legally enforceable standard or requirement for municipal water suppliers.** The action level focus on potential risk to human health and do not take into account other factors that must be considered when promulgating a final drinking water MCL standard, including technical feasibility and cost of water treatment, as well as naturally occurring Cr VI in water and natural dietary exposure.

The ideal goal for Cr VI in drinking water is “zero,” since Cr VI is not an essential nutrient and has been shown to be toxic over long periods of relatively high exposure. The natural occurrence of trace levels of Cr VI in our food and water, however, make this goal impractical. Naturally occurring, background Total Chromium in groundwater across the islands ranges from <2 $\mu\text{g/L}$ to approximately 15 $\mu\text{g/L}$ (see Table 1 in attachment). This is similar to the expected range of background Cr VI in groundwater on the mainland US. The geochemistry of the aquifers (e.g., well oxygenated and neutral pH) likewise suggests that chromium in the groundwater is likely to be dominated by Cr VI. [Followup sampling in 2011 confirmed that the majority of chromium in groundwater is Cr VI, with reported concentrations ranging from <2 $\mu\text{g/L}$ to 14 $\mu\text{g/L}$. This falls within the range of risk-based, drinking water action levels for Total Chromium noted above (i.e., 0.043 $\mu\text{g/L}$ to 20 $\mu\text{g/L}$). In most cases, the concentration of Cr VI falls below below USEPA’s conservative, upper-bound action level of 4.3 $\mu\text{g/L}$ for potential cancer risk.]

Long-term exposure to the trace levels of Cr VI likely to be naturally present in Hawaii’s groundwater (i.e., based on Total Chromium levels) has not been demonstrated to pose significant health risks in epidemiological studies or laboratory studies. As discussed below, the animal studies referred to for development of the cancer-based toxicity factor relied on exposures to Cr VI in drinking water six orders of magnitude higher than the lower-bound action level ($>14,300$ $\mu\text{g/L}$ vs 10^{-6} cancer-based action level of 0.043 $\mu\text{g/L}$, see Figure 1 of the attachment). Uncertainty in use of the cancer studies to predict long-term exposure to trace levels of Cr VI in drinking water is relatively high and the focus of much debate. Certainty in the noncancer studies and resulting action levels is much higher. Given this disparity, as well as the widespread, natural presence of trace levels Cr VI in groundwater and surface water, it is anticipated that any revision to the current MCL for Total Chromium will take natural background levels of Cr VI into account, provided that they fall within a range of risk-based action levels similar to that noted above.

Additional details are provided in the attachment to this memorandum.

(Attachment)

Overview of Chromium Occurrence, Toxicity and Drinking Water Action Levels

Chromium VI Occurrence in Nature

Chromium (Cr) is a naturally occurring element found in rocks, soil, water, animals and plants as well as volcanic dust and gases (Kotas 2000, IETEG 2005). The most common forms in the environment are metallic chromium, zero-valent chromium (Cr 0), trivalent chromium (Cr III) and hexavalent chromium (Cr VI). A fourth form of chromium, Cr V, is associated with steel making and other industrial processes but is not common in the environment.

Both Cr III and Cr VI occur naturally at trace amounts in groundwater and surface water in the presence of chromium bearing rocks, sediment or soil (IETEG 2005). The trace levels of chromium in groundwater are derived from naturally occurring chromium in the enclosing, basaltic bedrock (Sterns 1985, MacDonald et al. 1983). Background levels of total chromium in basalt can reach 2,000 mg/kg or higher (IETEG 2005). The concentration of Total Chromium in the volcanic soils of Hawai'i typically ranges from 100 to 500+ mg/kg and can exceed 1,000 mg/kg in places (USAF 2005, USN 2006, HDOH 2008). Chromium in the soil and rock is dominated by Cr III and metallic chromium (see Kotas 2000 and IETEG 2005). Although not regularly measured, a small percentage (e.g., <15%) of the Total Chromium is likely to be Cr VI (default percentage used in past USEPA guidance).

In oxygenated water with a neutral or higher pH ($\text{pH} \geq 7$), chromium is typically dominated by Cr VI, although this can vary in surface water due to various compounding factors (Kotas 2000). Between a pH of 6-7 chromium may be present as either Cr VI or Cr III. At a pH of <6 and/or under anoxic conditions, Cr III is generally dominant. Groundwater in the basaltic aquifers of the Hawai'i typically has a pH of ranges from 7-8 (personal communication, HDOH Safe Drinking Water Branch). [Expanded sampling in 2011 confirms that Total Chromium in groundwater on the islands is dominated by Cr VI.]

Based on HDOH Safe Drinking Water Branch data from the years 2000-2010, the natural, background concentration of total chromium in the basalt aquifers of Hawai'i ranges from <2 $\mu\text{g/L}$ to approximately 15 $\mu\text{g/L}$ (Table 1, see also Figure 1). Total chromium was below the upper-bound, cancer-based action level for Cr VI of 4.3 $\mu\text{g/L}$ in 93% to 100% of the samples collected from the Big Island, Maui and O'ahu. Eighty-percent of the samples from Kaua'i were below 4.3 $\mu\text{g/L}$. None of the samples exceeded the noncancer action level for Cr VI of 20 $\mu\text{g/L}$ noted above. The concentration of chromium in groundwater is in general lower in areas of relatively recent and unweathered basalt (e.g., Big Island) and somewhat higher in areas of older and more intensely weathered basalt (e.g., Kauai). This is due to increased weathering and leaching of chromium and other metals from the basalt and overlying soil.

Industrial Use of Chromium and Chromium VI

Chromium is used for making steel, chrome plating, dyes and pigments as well as in leather tanning and wood preservation (IETEG 2005). Products that contain Cr(VI) include paints, pigments, inks, fungicides, and wood preservatives. Chromium VI was also used in the past as a corrosion inhibitor. The release at the PG&E site in Hinkley, California was related to the disposal of cooling tower water treated with Cr VI into unlined ponds in the 1950s and 1960s (CalEPA 2007).

The industrial use of hexavalent chromium in Hawai'i is very limited. No significant plumes of Cr VI-contaminated groundwater have been identified. Chromium was not used as an agricultural pesticide aside from wood treatment. Leaching of chromium from treated wood and potential impacts on groundwater is considered to be insignificant. In particular, there are no known industrial sources of Cr VI in Hawai'i that could lead to widespread contamination of groundwater.

Note that the naturally occurring level of total chromium (including Cr VI) in the groundwater of Hawai'i, as well as other areas, is significantly lower than contamination typically associated with industrial releases of hexavalent chromium (see Figure 1). For example, the concentration of Cr VI in contaminated groundwater associated with the PG&E Chromium VI case in Hinkley, California, exceeded 3,000 µg/L in the source area (PG&E 2007). A regional, natural background level of 3.1 µg /L Cr VI in groundwater is being used to map and monitor the edge of the plume (95th percent upper threshold limit).

Dietary Exposure to Chromium

Both Cr III and Cr VI are naturally occurring in foods, although total chromium is expected to be dominated by Cr III. Dietary sources of chromium include lean meats, cheese, whole grain breads and cereal (Roussel et al. 2007). Cr III is an essential nutrient in the human diet. The follow information is provided in the USEPA Toxicological Review for chromium (USEPA 1998):

- Adults in the United States are estimated to ingest approximately 60 µg/day of chromium from food;
- The National Research Council reports a safe and adequate daily dietary intake for chromium of 50-200 µg/d, corresponding to 0.71-2.9 µg/kg/day for a 70 kg adult;
- The US Food and Drug Administration recommends a dietary Reference Daily Intake for chromium of 120 µg/d (DHHS, 1995).

The concentration of total chromium in wheat has been reported to be several hundred parts-per-billion (in Soares et al. 2010). Hexavalent chromium is generally assumed to be reduced to trivalent chromium in plants. Although data are limited, a small percentage of the Total Chromium in food is likely to be in the form of Cr VI. The relative proportion of Cr VI in foods has been reported to be up to 10% of total chromium in breads (Soares et al. 2010). If representative of foods in general, this suggests a dietary intake of Cr VI of 5 to 20 µg/day (based on NRC safe and adequate dietary intake).

Toxicology and Toxicity Factors

Chromium III is an essential nutrient and is not toxic at levels typically found in nature. Chromium VI is more water soluble, easily enters living cells and is much more toxic than Chromium III. In 2010 the USEPA published a draft, human health assessment for Cr VI (USEPA 2010a). The study is currently under peer review and public comment.

Noncancer Risks

In animal laboratory tests exposure to Cr VI has been observed to cause cellular changes to liver, small intestine and lymph nodes. A noncancer, oral Reference Dose (RfD) for Cr VI of 0.003 mg/kg-day is presented in the USEPA Integrated Risk Information System database (IRIS, USEPA 2010b) and referred to in the 2010 edition of the USEPA *Regional Screening Level* guidance (2010c). The basis of the RfD is summarized in an earlier review of Cr VI toxicity (USEPA 1998). The USEPA referred to an RfD for Cr VI of 0.005 mg/kg-day prior to the 1998 study. As discussed in a 2010 review of existing drinking water standards, this reference dose forms the basis of the current Maximum Contaminant Level (MCL) for Total Chromium (USEPA 2010d, see also next section).

Confidence in the current USEPA RfD for Cr VI of 0.003 mg/kg-day is stated in the IRIS database to be low. A composite uncertainty factor of 900 was used to generate the RfD. An alternative RfD of 0.0002 mg/kg-day was presented in a 2008 review of Cr VI toxicity published by the National Toxics Program with an associated uncertainty factor of 1,000 (USDHHS 2008). The more recent, 2010 USEPA draft, human health assessment for Cr VI proposes an RfD of 0.0009 mg/kg-day for hexavalent chromium and incorporates a composite uncertainty factor of 100 (USEPA 2010d). Confidence in the draft, revised RfD is higher than for the current RfD. This suggests that the accuracy of drinking water action levels based on the RfD will also be relatively high.

Cancer Risks

Chromium VI has been demonstrated to cause cancer of the small intestine in mice at higher doses by the oral route of exposure (USDHHS 2008). The USEPA toxicity review of Cr VI (USEPA 2010a) references an oral Cancer Slope Factor (CSF) for Cr VI of $0.5 \text{ (mg/kg-day)}^{-1}$, based on a study published by the state of New Jersey (NJDEP 2009). The study found Cr VI to be carcinogenic in cases where laboratory animals were exposed to high concentrations of Cr VI in their drinking water ($>14,300 \text{ }\mu\text{g/L}$) for two years. The New Jersey CSF is also referred to in the USEPA *Regional Screening Levels* guidance to develop risk-based, soil and water screening levels (USEPA 2010c). As stated in the document supporting the New Jersey CSF, there is significant uncertainty in application of the CSF for very small doses of Cr VI over long periods of exposure (NJDEP 2009):

“The USEPA default procedure for calculation of cancer potency that was employed herein linearly extrapolates across 5 orders of magnitude of cancer incidence from the data-based

benchmark incidence rate (BMR) of 0.1 to estimate the dose at 1×10^{-6} (one-in-a million) cancer incidence. The shape of the dose-response function is not known below the range of the observed data, and the linear extrapolation across so large a range carries significant uncertainty.”

Because Cr VI was also found to be mutagenic, USEPA guidance recommends that an additional, Age-Dependent Adjustment Factor (ADAF) be incorporated into equations for calculation of cancer-based action levels (USEPA 2010a). The USEPA Regional Screening Level for Cr VI in tap discussed in the following section incorporates an ADAF of 10.

Use in Developing Drinking Water Action Levels

The draft, 2010 USEPA noncancer RfD reflects a relatively high degree of certainty and is useful for estimation of an upper-bound action level for Cr VI. The Cancer Slope Factor for Cr VI requires significant extrapolation from high-dose animal studies for estimation of risk posed by long-term, low-dose exposures. The resulting action levels serve as very conservative, lower-bound, risk-based goals for the range of acceptable drinking water action levels. Use of the noncancer RfDs and cancer-based CSFs in published, risk-based standards and action levels for Cr VI in drinking water is discussed in the following sections.

Current USEPA Standards and Screening Levels

USEPA Drinking Water Standard

Table 1 summarizes existing drinking water standards, goals and screening levels for Total Chromium and Cr VI. The USEPA provided a review of existing drinking water standards in a 2010 notice to the Federal Register (USEPA 2010d). The current USEPA and Hawai'i DOH drinking water standard for chromium is 100 µg/L, based on measured Total Chromium. The basis for the standard is a pre-1998, noncancer RfD for Cr VI of 0.005 mg/kg-day and a target Hazard Quotient of 1.0 (see above; USEPA 2010d). Note that this contradicts and corrects recent media statements about the lack of a drinking water standard for hexavalent chromium. The existing standard is in fact based on an assumption that 100% of the total chromium in drinking water is in fact Cr VI, as recently acknowledged in a USEPA Fact Sheet (USEPA 2011). As discussed in the 2010 USEPA review, the initial risk-based concentration for exposure to Cr VI was reduced by 30% to take into account exposure from other sources, including diet (i.e., Relative Source Contribution of 70% assumed).

The drinking water standard is based on single value for Total Chromium instead of separate standards for both Chromium III and Chromium VI due in part to the expense and difficulty in testing for Chromium VI at standard, commercial laboratories. Among other issues, water samples to be tested for Chromium VI must be delivered to the laboratory within twenty-four hours for analysis to minimize potential conversion to Chromium III after sampling. Reporting Total Chromium, and conservatively assuming that 100% of the chromium is Cr VI, is a more cost-efficient approach for regulating Cr VI in drinking water.

Attachment 1

The USEPA concluded in their 2010 review of drinking water standards (USEPA 2010d) that the current standard for Total Chromium is still considered to be protective of human health, based on existing, published studies. When the current assessment (USEPA 2010a) is finalized, however, USEPA will review the conclusions and consider all relevant information to determine if the current standard should be revised.

Other Published Screening Levels and Goals

A non-enforceable, risk-based, tapwater screening level for Cr VI of 0.043 µg/L is published in the USEPA Regional Screening Levels (RSL) guidance (USEPA 2010c). The screening level is based on the New Jersey CSF of 0.5 (mg/kg-day)⁻¹, discussed above and a target excess cancer risk of 10⁻⁶ (one-in-a-million). The screening level also incorporates an age-sensitivity safety factor of “10” in order to take into account potential mutagenic effects posed to young children by Cr VI. A noncancer-based tapwater screening level for Cr VI of 110 µg/L is also presented in the USEPA RSL guidance, based on the current IRIS RfD of 0.003 mg/kg-day presented in the USEPA IRIS database and a target Hazard Quotient of 1.0. Although not yet incorporated into the USEPA RSLs, use of the revised, draft RfD for Cr VI of 0.0009 mg/kg-day (USEPA 2010a) would reduce the noncancer-based tapwater screening level from 110 µg/L to 33 µg/L. Incorporation of the updated RfD in the model used to develop the current drinking water standard of 100 µg/L would lower the standard to approximately 20 µg/L (assumes 30% additional dietary source of Cr VI).

The California’s Office of Environmental Health Hazard Assessment (OEHHA) has proposed a draft, non-enforceable, Public Health Goal (PHG) of 0.02 µg/L for Cr VI in drinking water (CalEPA 2010). The PHG is based on the New Jersey CSF of 0.5 (mg/kg-day)⁻¹, a one-in-a-million carcinogenic health risk and a slightly modified approach for the inclusion of age-dependent adjustment factors in the risk equations in comparison to the USEPA tapwater RSL. The California PHG document also recommends a noncancer-based PHG of 2 µg/L, based on the RfD of 0.0002 mg/kg-day presented in the 2008 NTP report referenced above (USDHHS 2008). The NTP RfD incorporates a relatively high uncertainty factor (composite UF = 1,000) in comparison to the RfD of 0.0009 mg/kg-day and subsequently proposed in the draft, USEPA review of Cr VI toxicity (composite UF = 100).

Comparison of Action Levels to Natural Background

A summary of the range of potential health-based action levels for Cr VI in drinking water is provided in the table of the main text and noted on Figure 1. Although data are limited, the geochemistry of the island aquifers (e.g., well oxygenated and neutral pH) suggests that chromium in the groundwater is likely to be dominated by Cr VI. Assuming this is the case, the naturally occurring concentration of Cr VI in groundwater across the islands falls within the range of risk-based, drinking water action levels for Total Chromium noted above. In most cases, the concentration of Cr VI is likewise anticipated to fall at or below USEPA’s conservative,

Attachment 1

upper-bound action level of 4.3 µg/L for potential cancer risk. Long-term exposure to the trace levels of Cr VI likely to be naturally present in Hawaii's groundwater (i.e., based on Total Chromium levels) have not been demonstrated to pose significant health risks in epidemiological studies or laboratory studies.

References

- Boyce, C.P., Lewis, A.S., Sax, S.N., Eldan, M, Cohen, S.M. and B.D., Beck, Probabilistic Analysis of Human Health Risks Associated with Background Concentrations of Inorganic Arsenic: Use of a Margin of Exposure Approach: Human and Ecological Risk Assessment, Vol. 14, p. 1159–1201.
- CalEPA, 2010, *Draft Public Health Goal for Hexavalent Chromium in Drinking Water* (December 2010): California Environmental Protection Agency, Office of Environmental Health Hazard Assessment, <http://www.oehha.ca.gov/water/phg/pdf/123110Chrom6.pdf>
- HIDOH, 2008, *Evaluation of Environmental Hazards at Sites with Contaminated Soil and Groundwater* (Summer 2008, updated March 2009): Hawai'i Department of Health, Office of Hazard Evaluation and Emergency Response, www.hawaii.gov/health/environmental/hazard/eal2005.html.
- IETEG, 2005, *Chromium (VI) Handbook*: Independent Environmental Technical Evaluation Group (editors Guertin, J., Jacobs, J.A. and Avakian, C.P.), CRC Press, Washington, DC, ISBN 1-56670-608-4.
- Kotas, J. and Stasicka, J., 2000, Chromium occurrence in the environmental and methods of its speciation: *Environmental Pollution* 107 (2000), p. 263-293.
- MacDonald, G.A., Abbott, A.T. and Peterson, F.L., 1983, *Volcanoes of the Sea, The Geology of Hawai'i*: University of Hawai'i Press, Honolulu, Hawai'i, ISBN 0-8248-0832-0.
- NJDEP, 2009, Derivation of Ingestion-Based Soil Remediation Criterion for Cr+6 Based on the NTP Chronic Bioassay Data for Sodium Dichromate Dihydrate (April 8, 2009): New Jersey Department of Environmental Protection, <http://www.state.nj.us/dep/dsr/chromium/soil-cleanup-derivation.pdf>
- PG&E, 2007, *Groundwater Background Study Report, Hinkley Compressor Station, Hinkley, California*: Pacific Gas and Electric Company (February 2007), prepared by CH2MHill, https://geotracker.waterboards.ca.gov/esi/uploads/geo_report/1898196160/SL0607111288.PDF.
- Roussel, A., Andriollo-Sanchez, M., Ferry, M., Bryden, N.A. and Anderson, R.A., 2007, Food Chromium content, dietary chromium intake and related biological variables in French free-living elderly: *British Journal of Nutrition*, Vol. 98, p. 326-331.
- Soares, M.E., Viera, E. and M.L. Bastos, 2010, Chromium Speciation Analysis in Bread Samples: *Journal of Agricultural; Food Chemistry*, Vol. 58, p. 1366–1370.

Attachment 1

Stearns, H.T., 1985, *Geology of the State of Hawai'i*: Pacific Books Publishers, Palo Alto, California, ISBN0-87015-234-3.

USAF, 2005, *Base-wide Ambient Metals Study, Hickam Air Force Base, O'ahu, Hawai'i* (August 26, 2005): US Air Force, 15th Airlift Wing, Environmental Restoration Program.

USDHHS 2008, *Technical Report on the Toxicology and Carcinogenesis Studies of Sodium Dichromate Dihydrate in F344/N Rats and B6C3F1 Mice*: U.S. Department of Health and Human Services, National Toxicology Program, NTP TR 546, NIH Publication No. 07-5887, http://ntp.niehs.nih.gov/ntp/htdocs/LT_rpts/tr546.pdf.

USEPA, 1998, *Toxicological Review of Hexavalent Chromium*: U.S. Environmental Protection Agency, Integrated Risk Information System (IRIS), <http://www.epa.gov/iris/toxreviews/0144tr.pdf>

USEPA, 2010a, *IRIS Toxicological Review of Hexavalent Chromium, External Review Draft* (September 2010): U.S. Environmental Protection Agency, Washington, DC, EPA/635/R-10/004A, www.epa.gov/iris

USEPA, 2010b, Chromium VI: U.S. Environmental Protection Agency, Integrated Risk Information System (IRIS), <http://www.epa.gov/iris/index.html>

USEPA, 2010c, Screening Levels for Chemical Contaminants: U.S. Environmental Protection Agency, November 2010, prepared by Oak Ridge National Laboratories, <http://www.epa.gov/region09/waste/sfund/prg/>

USEPA, 2010d, National Primary Drinking Water Regulations; Announcement of the Results of EPA's Review of Existing Drinking Water Standards: U.S. Environmental Protection Agency, Federal Register Notice, Vol. 75, No. 59 (Monday, March 29, 2010), <http://edocket.access.gpo.gov/2010/pdf/2010-6624.pdf>.

USN, 2006, *Environmental Background Analysis of Metals in Soil at Navy O'ahu Facilities, O'ahu, Hawai'i* (June 6, 2006): Department of the Navy, Naval Facilities Engineering Command, Hawai'i.

Island	*Total Number of Samples	Number of Samples Within Noted Range of Total Chromium ($\mu\text{g/L}$)					Maximum Reported Total Chromium ($\mu\text{g/L}$)
		≤ 2.0	$>2.0-4.3$	$>4.3-10$	$>10-20$	>20	
Big Island	424	322	88	14	0	0	8
Maui	304	269	35	0	0	0	4
O'ahu	695	488	161	29	17	0	14
Kauai	308	110	134	61	3	0	11

*Includes multiple samples from some sampling points, mixed pre- and post wellhead data.

Island	*Total Number of Samples	Number of Samples Within Noted Range of Total Chromium ($\mu\text{g/L}$)					Maximum Reported Total Chromium ($\mu\text{g/L}$)
		<2.0	$>2.0-4.3$	$>4.3-10$	$>10-20$	>20	
Big Island	424	76%	21%	3%	0%	0%	8
Maui	304	88%	12%	0%	0%	0%	4
O'ahu	695	70%	23%	4%	2%	0%	14
Kauai	308	36%	44%	20%	1%	0%	11

Table 1. Summary of Total Chromium in groundwater in Hawai'i (2001-2010).

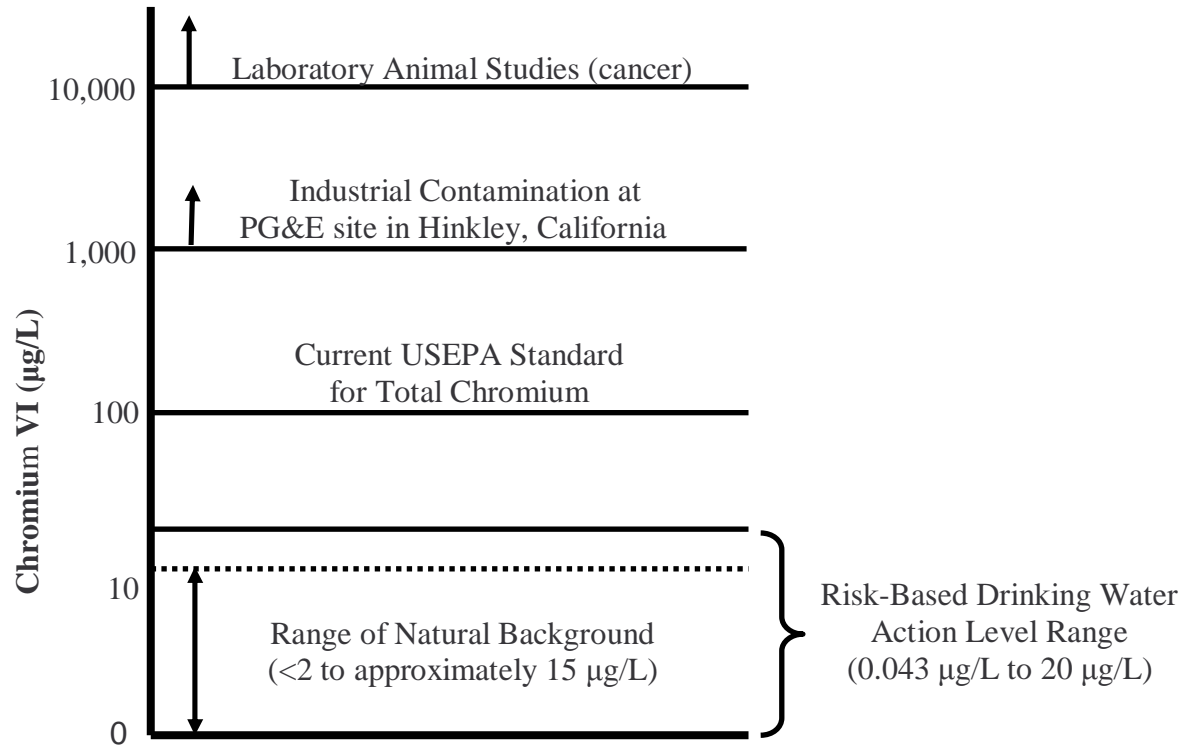

Figure 1. Comparison of natural background Total Chromium in groundwater across Hawai'i to risk-based range of drinking water action levels and other criteria.

APPENDIX 9

UPDATES TO 2017 HIDOH EHE GUIDANCE

HDOH EHE Guidance

Appendix 9: Summary of Fall 2017 Updates

Volume 1:

- Summary EAL tables updated to reflect updates to detailed action level tables in Volume 2, Appendix 1.

Volume 2:

Appendix 1 Text:

- Section 6 text updated to summary HDOH laboratory study of the BTEXMN and carbon range makeup of common petroleum fuels;
- Updates to carbon range-weighted toxicity factors for specific fuel categories based on results of laboratory study of fuels noted.
- Guidance on the need to sum laboratory data for Purgeable Organic Carbon (e.g., GRO) and Extractable Organic Carbon (e.g., DRO and RRO) for comparison to TPH groundwater action levels added.

Appendix 1 Tables (and associated models):

- Table H updated to reflect updates to physiochemical constants and toxicity factors for compounds presented in the November 2023 update to the USEPA Regional Screening Levels guidance (updated noted in below table);
- Carbon range-weighted toxicity factors for TPH associated with neat-, vapor and dissolved-phase gasolines, middle distillates and residual fuels updated.

Appendix 6:

- BTEXMN and carbon range data for fuel samples tested on behalf of HDOH provided;
- Summary text and table added to describe the methodology use calculation of carbon range-weighted TPH toxicity factors for gasolines, middle distillates and fuel types.

Other:

- EAL Surfer (electronic lookup tables) updated to reflect updates to detailed action level tables in Volume 2, Appendix 1.

Appendix 9: Summary of Fall 2017 Updates

2024 HDOH EAL ¹Updates, Affected Action Levels:

Chemical	Revision	Affect screening levels
Acetone	Updated USEPA Koc, Henry's Law constant (more conservative)	Soil, indoor air, subslab vapor
Amino, 2-Dinitrotoluene 4,6- and 2,6-	Updated USEPA RfD (more conservative)	Soil, drinking water (toxicity)
Antimony	New USEPA RfC	EALs not affected (risk driven by ingestion)
Atrazine	Updated USEPA RfD (more conservative)	EALs not affected (based on cancer risk)
Bromodichloromethane	Updated USEPA RfD	EALs not affected (based on cancer risk)
Cadmium	Additional review of natural background (less conservative)	Soil
Chloroaniline, p-	Updated USEPA RfD	EALs not affected (based on cancer risk)
Chloroethane	Updated USEPA RfC (more conservative)	Soil, drinking water (toxicity)
Cyclo-1,3,5-trimethylene-2,4,6-trinitramine (RDX)	Updated USEPA CSF and RfD (less conservative)	Soil, drinking water (toxicity)
DDT, DDE	Updated USEPA RfD	EALs not affected (based on cancer risk)
Dichloroethylene, Cis 1,2-	New USEPA RfCs (less conservative)	Soil, indoor air, subslab vapor, drinking water (toxicity)
Dichloroethylene, Trans 1,2-	New USEPA RfCs (more conservative)	Soil, indoor air, subslab vapor, drinking water (toxicity)
Ethylbenzene	Updated USEPA RfD (more conservative)	EALs not affected (based on cancer risk)
Heptachlor	Updated USEPA RfD (more conservative)	EALs not affected (based on cancer risk)
Hexachlorobenzene	Updated USEPA RfD (more conservative)	EALs not affected (based on cancer risk)
Molybdenum	Updated USEPA RfC (more conservative)	EALs not affected (risk driven by ingestion)
Nickel	Updated USEPA RfC (more conservative)	EALs not affected (driven by natural background)
Pentaerythritoltetranitrate (PETN)	Updated USEPA CSF and RfD (less conservative)	Soil, drinking water (toxicity)
Tert-Butyl Alcohol	Updated USEPA Koc, Diffusivity constants, Henry's Law constant, CSF, RfD, RfC (less conservative)	Soil, drinking water (toxicity)
Toxaphene	Updated USEPA RfD (more conservative)	EALs not affected (based on cancer risk)
TPH (gasolines)	Updated USEPA RfD for C6-C8 aliphatics (more conservative) and RfD and RfC for >C8 aromatics (more conservative)	Soil, indoor air, subslab vapor, drinking water
TPH (middle distillates)		
TPH (residual fuels)		

Notes

1. Minor updates to physiochemical constants that did not affect action levels not summarized. Refer to redline text in Table H for additional updated values.